

USB-PDISO8, USB-ERB, and USB-SSR Series



USB-PDISO8 Series

USB-ERB Series

USB-SSR Series

Overview

Measurement Computing DIO high voltage and relay USB product offerings include the USB-PDISO8 Series, USB-ERB Series, and USB-SSR Series.

The USB-PDISO8 Series offers eight isolated AC or DC inputs and eight electro-mechanical relays in a single digital I/O system. The USB-ERB Series enables a PC or laptop to control eight to 24 electromechanical relays.

The USB-SSR Series can monitor and control eight to 24 standard size solid state relay (SSR) I/O modules (relays sold separately).

All devices in these series come in a heavy-duty metal enclosure with integrated mounting slots, which ensures that the devices are rugged enough for any DAQ application.

Relay Contacts and Connectors

USB-PDISO8/USB-ERB Series Only

The USB-PDISO8 and USB-ERB Series devices provide screw terminal connections to the relay contacts. The USB-PDISO8/40 provides relay connections through a 40 pin connector.

Each relay has a normally closed (NC), common (C), and normally open (NO) contact. Relays on all devices are controlled by digital I/O lines.

SSR Digital I/O Control Modules

USB-SSR Series Only

The USB-SSR08 provides mounting locations for eight SSR digital I/O modules, and the USB-SSR24 provides mounting locations for 24 SSR modules.

SSR digital I/O modules are relay control modules that provide 4000 Vrms of optical isolation. Digital input modules sense AC/DC voltages from field devices and convert them to digital TTL signals. Digital output modules use TTL signals to switch and control AC/DC loads.

A wide selection of SSR digital I/O modules are available to switch or sense a large range of AC or DC voltages.

Features

- **USB-PDISO8 Series**
 - 8 Form C relays
 - 8 isolated AC or DC inputs
- **USB-ERB Series**
 - 8 or 24 Form C single-pole double-throw (SPDT) electromechanical relays.
- **USB-SSR Series**
 - 8 or 24 input or output channels to control and monitor solid state relays.
- Screw terminal or header connectors
- Heavy-duty chassis with integrated mounting slots
- Includes external power supply (required for all devices)

Supported Operating Systems

- Windows 10/8/7/Vista®/XP 32/64-bit
- Linux®

The SSR modules use a standard color scheme to help quickly identify the module type installed.



Compatible SSR modules are available separately (refer to [SSR Digital I/O Modules](#) on page 10).

USB-PDISO8 Series, USB-ERB Series, and USB-SSR Series Selection Chart

Model	Relay Channels	Contact Rating	Daisy Chain Support	Signal I/O Connector
USB-PDISO8	8 Form C (SPDT)	6 amps at 240 VAC/28 VDC	✓	40-pin screw terminal
USB-PDISO8/40	8 Form C (SPDT)	6 amps at 240 VAC/28 VDC	✓	40-pin header connector
USB-ERB08	8 Form C (SPDT)	6 amps at 240 VAC/28 VDC	✓	24-pin screw terminal
USB-ERB24	24 Form C (SPDT)	6 amps at 240 VAC/28 VDC	✓	72-pin screw terminal
USB-SSR08	8 Solid State Relay Modules	–	✓	16-pin screw terminal
USB-SSR24	24 Solid State Relay Modules	–	✓	48-pin screw terminal

Features

I/O Module Type Switch

USB-SSR Series devices have an onboard switch to configure each module group for either input or output.

Devices are shipped with all modules configured for output. Input and output modules cannot be mixed within a group.

Positive and negative relay contacts are brought out to screw terminals for field wiring connections.

Relay Configuration Switches

USB-ERB/USB-SSR Series Only

USB-SSR Series and USB-ERB Series devices have two onboard switches for configuring the relay logic polarity and output relay power-up state for each relay bank/SSR module group. The current configuration of each switch can be read back with software.

Devices are shipped with all relay banks/module groups configured for non-inverted logic and pull-up (relays/modules inactive on power-up).

Differential Isolated Digital Inputs

USB-PDISO8 Series Only

All eight inputs on USB-PDISO8 Series devices can be driven by either AC (50 Hz to 1000 Hz) or DC voltage, and can be read back as a single byte.

Each input has a software-selectable filter with a time constant of 5 ms (200 Hz). The filter is required for AC inputs, and recommended for most DC inputs.

Each module group can be set to either input or output (default). Input and output modules cannot be mixed within a group.

Up to eight optically isolated (500 V) digital input connection pairs are available from the signal I/O connector on USB-PDISO8 Series devices.

Each signal is applied to a bridge rectifier so that the input is not polarity-sensitive.

External Power

USB-PDISO8 Series devices require between 6.5 V and 12.5 V of external power. USB-SSR Series and USB-ERB Series devices require between 6.0 V and 12.5 V of external power.

An external power connection using the included external power supply is required to activate relays and SSR modules, and to run tests in software.

- USB-PDISO8 Series devices, USB-SSR Series devices, and the USB-ERB08 are powered by a 9 VDC nominal, 1.0 A external power supply (CB-PWR-9) that ships with each device.
- The USB-ERB24 is powered by an external 9 V, 3 A regulated power supply (CB-PWR-9V3A) that ships with the device.

Daisy Chaining Multiple Devices

MCC high-voltage/relay DIO devices can be optionally daisy chained to connect to the USB bus through the high-speed hub on the host device – USB-PDISO8 Series, USB-SSR Series, or USB-ERB Series.

Up to four MCC USB devices can be daisy chained using a single USB port on the PC. Use the supplied cable or an equivalent cable when daisy chaining MCC USB Series products.

When daisy chaining MCC high-voltage/relay DIO devices, make sure adequate power is provided to each connected device.

Voltage Drop

A drop in voltage occurs with each device connected in a daisy chain configuration. The voltage drop between the power supply input and the daisy chain output is 0.5 V maximum. Factor in this voltage drop when configuring a daisy chain system to ensure that at least 6.0 VDC is provided to the last device in the chain.

Supply Current

The following devices may require addition external power adapters depending on the number of connected devices:

Device	External Power Consumption (All Relays/SSR Modules On)
USB-PDISO8 Series	Draws 820 mA from the 1 A supply
USB-ERB08	Draws 750 mA from the 1 A supply
USB-ERB24	Draws 1.5 A from 3 A supply
USB-SSR24	Draws 800 mA from the 1 A supply
USB-SSR08	Draws 300 mA from the 1 A supply

Some devices may require their own external power supply in a daisy chain configuration.

If unsure as to how much current an application requires, MCC recommends providing separate power to each connected device.

Software

Software Support

The USB-PDISO8, USB-ERB, and USB-SSR Series devices are supported by the software in the table below.

Ready-to-Run Applications		
DAQami™		<p>Data acquisition companion software with drag-and-drop interface that is used to acquire, view, and log data, and generate signals. DAQami can be configured to log analog, digital, and counter channels, and to view that data in real-time or post-acquisition on user-configurable displays. Logged data can be exported for use in Excel® or MATLAB®. Windows OS</p> <p>DAQami is included with the free MCC DAQ Software bundle. Install DAQami and try the fully-functional software for 30 days. After 30 days, all features except for data logging and data export will continue to be available – data logging and data export features can be unlocked by purchasing the software.</p>
InstaCal™		<p>An interactive installation, configuration, and test utility for MCC hardware. Windows OS</p> <p>InstaCal is included with the free MCC DAQ Software bundle.</p>
TracerDAQ™ and TracerDAQ Pro (USB-PDISO8 Series digital inputs only)		<p>Virtual strip chart, oscilloscope, function generator, and rate generator applications used to generate, acquire, analyze, display, and export data. Supported features may vary by hardware. The Pro version provides enhanced features. Windows OS</p> <p>TracerDAQ is included with the free MCC DAQ Software bundle.</p> <p>TracerDAQ Pro is available as a purchased software download.</p>
General-Purpose Programming Support		
Universal Library™ (UL) for Windows		<p>Library for developing applications in C, C++, VB, C# .Net, VB .Net, and Python on Windows.</p> <p>The UL for Windows is included with the free MCC DAQ Software bundle.</p> <p>The UL Python API for Windows is available on GitHub (github.com/mccdaq/mcculw).</p>
UL for Linux®		<p>Library for developing applications in C, C++, and Python on Linux.</p> <p>UL for Linux is available on GitHub (github.com/mccdaq/uldaq).</p> <p>Open-source, third-party Linux drivers are also available for supported MCC devices.</p>
Application-Specific Programming Support		
ULx for NILabVIEW™		<p>A comprehensive library of VIs and example programs for NI LabVIEW that is used to develop custom applications that interact with most MCC devices. Windows OS</p> <p>ULx for NI LabVIEW is included with the free MCC DAQ Software bundle.</p>
DASYLab®		<p>Icon-based data acquisition, graphics, control, and analysis software that allows users to create complex applications in minimal time without text-based programming. Windows OS</p> <p>DASYLab is available as a purchased software download. An evaluation version is available for 28 days.</p>
MATLAB® Driver		<p>High-level language and interactive environment for numerical computation, visualization, and programming. The Mathworks Data Acquisition Toolbox™ allows users to acquire data from most MCC PCI and USB devices.</p> <p>Visit www.MathWorks.com for more information about the Data Acquisition Toolbox.</p>

Specifications - USB-PDISO8 Series

USB-PDISO8 Series Block Diagram

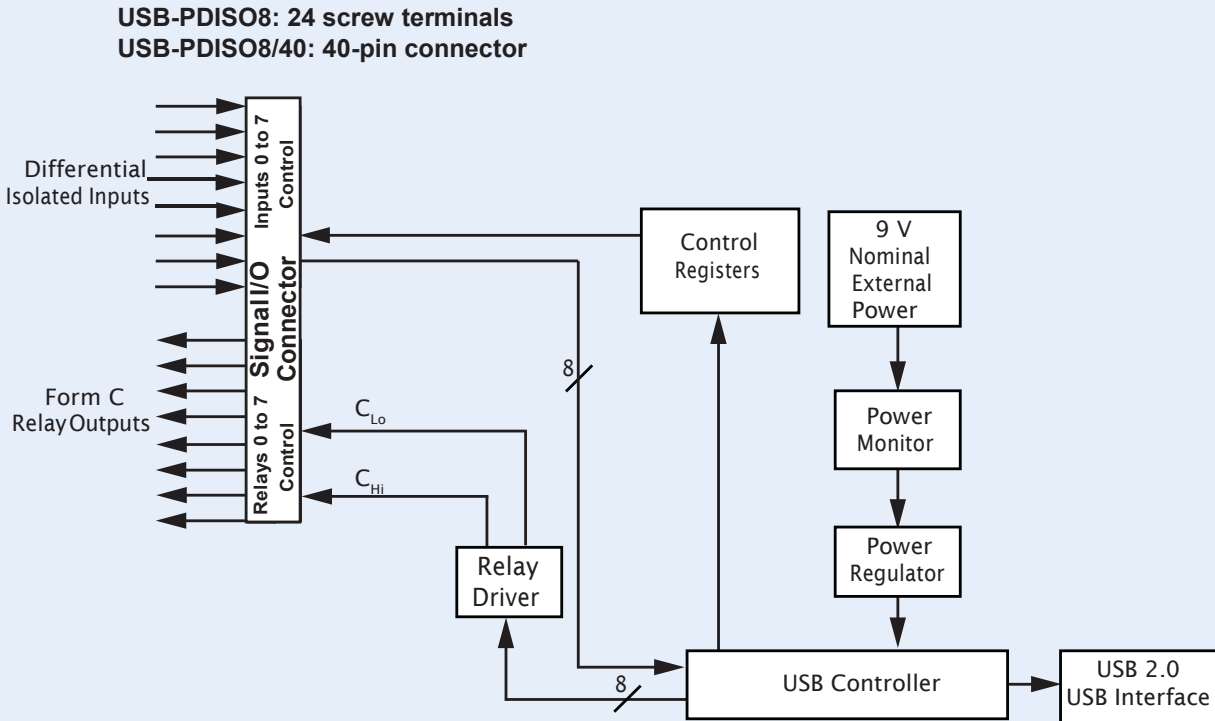

Specifications

All specifications are subject to change without notice.
 Typical for 25 °C unless otherwise specified.

USB-PDISO8 Series

Relay specifications

Number: 8

Contact configuration: 8 FORM C (SPDT) NO, NC, and Common available at connector.

Contact rating: 6 A @ 240 VAC or 28 VDC resistive (refer to [Main Connector](#) on page 5)

Contact resistance: 100 mΩ max

Operate time: 10 ms max

Release time

USB-PDISO8: 5 ms max

USB-PDISO8/40: 10 ms max

Vibration: 10 Hz to 55 Hz (dual amplitude 1.5 mm)

Shock: 10 G (11 ms)

Dielectric isolation: 500 V (1 minute)

Life expectancy: 10 million mechanical operations, min

Power on RESET state: Not energized. NC in contact to Common.

Isolated inputs

Number: 8

Isolation: 500 V

Resistance: 1.6 KΩ min

Voltage range (DC)

Input high: +5.0 VDC min or -5.0 VDC min

Input low: +1.5 VDC max or -1.5 VDC max

Input range: 30 VDC max

Voltage range (AC with filter)

Input high: 6.0 Vrms min (50 Hz to 1000 Hz)

Input low: 1.5 Vrms max (50 Hz to 1000 Hz)

Response

Filter disabled: 20 μs

Filter enabled: 5 ms

Filters

Time constant: 5 ms (200 Hz)

Filter control: Software-selectable for each input.

Power-up /reset: Filters disabled

Power

USB +5 V input voltage range: 4.75 V to 5.25 V

USB +5 V supply current: All modes of operation: 10 mA max

External power input: 9 V nominal

External power supply (required): MCC p/n CB-PWR-9: 9 V ±10% @ 1 A

Voltage supervisor limits - PWR LED

6.5 V > Vext or Vext > 12.5 V: PWR LED = Off (power fault)

USB-PDISO8 Series devices monitor the external +9 V power supply voltage with a voltage supervisory circuit. If this power supply exceeds its specified limit, the PWR LED turns off, indicating a power fault condition.

6.5 V ≤ Vext < 12.5 V: PWR LED = On

External power consumption

All relays on, 100 mA downstream hub power: 820 mA typ, 900 mA max

All relays off, 0 A downstream hub power: 200 mA typ, 230 mA max

Specifications - USB-PDISO8 Series

External power output

External power output - current range: 4.0 A max

The daisy chain power output option allows multiple MCC USB products with a USB hub output port to be powered from a single external-power source in a daisy-chain fashion. The voltage drop between the device power supply input and the daisy-chain output is 0.5 V maximum. Users must plan for this drop to assure the last device in the chain receives at least 6.5 VDC.

External power output: Voltage drop between power input and daisy chain power output: 0.5 V max

Compatible cable(s) for daisy chain: C-MAPWR-x: x = 2, 3, or 6 feet

USB Specifications

USB Type-B connector: Input

USB device type: USB 2.0 (full-speed)

Device compatibility: USB 1.1, USB 2.0

USB-PDISO8: Hardware revision F and later are also compatible with USB 3.0. The revision is indicated on the part number label on the housing
- 197241X-01 - where X is the hardware revision.

USB-PDISO8/40: Hardware revision C and later are also compatible with USB 3.0. The revision is indicated on the part number label on the housing
- 197242X-01 - where X is the hardware revision.

USB Type-A connector: Downstream hub output port

USB hub type: Supports USB 2.0 high-speed, full-speed and low-speed operating points; self-powered, 100 mA max downstream VBUS capability

Compatible products: MCC USB products with a USB hub output port

USB cable type (upstream and downstream): A-B cable, UL type AWM 2527 or equivalent (min 24 AWG VBUS/GND, min 28 AWG D+/D-)

USB cable length: 3 meters max

Mechanical

USB-PDISO8 dimensions (L × W × H)

PCB: 304.3 × 121.9 × 20.0 mm (12.0 × 4.8 × 0.8 in.)

Enclosure: 342.9 × 125.7 × 58.9 mm (13.5 × 4.95 × 2.32 in.)

USB-PDISO8/40 dimensions (L × W × H)

PCB: 304.3 × 121.9 × 17.8 mm (12.0 × 4.8 × 0.7 in.)

Enclosure: 342.9 × 125.7 × 58.9 mm (13.5 × 4.95 × 2.32 in.)

Environmental

Operating temperature range: 0 °C to 70 °C

Storage temperature range

USB-PDISO8: -40 °C to 100 °C

USB-PDISO8/40: -40 °C to 85 °C

Humidity: 0% to 95% non-condensing

Main Connector

USB-PDISO8

Connector type: Screw terminal

Wire gauge range: 12 AWG to 22 AWG

USB-PDISO8/40

Connector type: P14: 40-pin header

Compatible cables

C40FF-x: 40-conductor ribbon cable, female both ends, x = length in feet.

C40-37F-x: 40-pin IDC to 37-pin female D connector, x = length in feet.

Compatible accessory products

Using the C40FF-x cable: CIO-MINI40

Using the C40-37F-x cable: CIO-MINI37

Max current: 1 A

USB-ERB08 Block Diagram

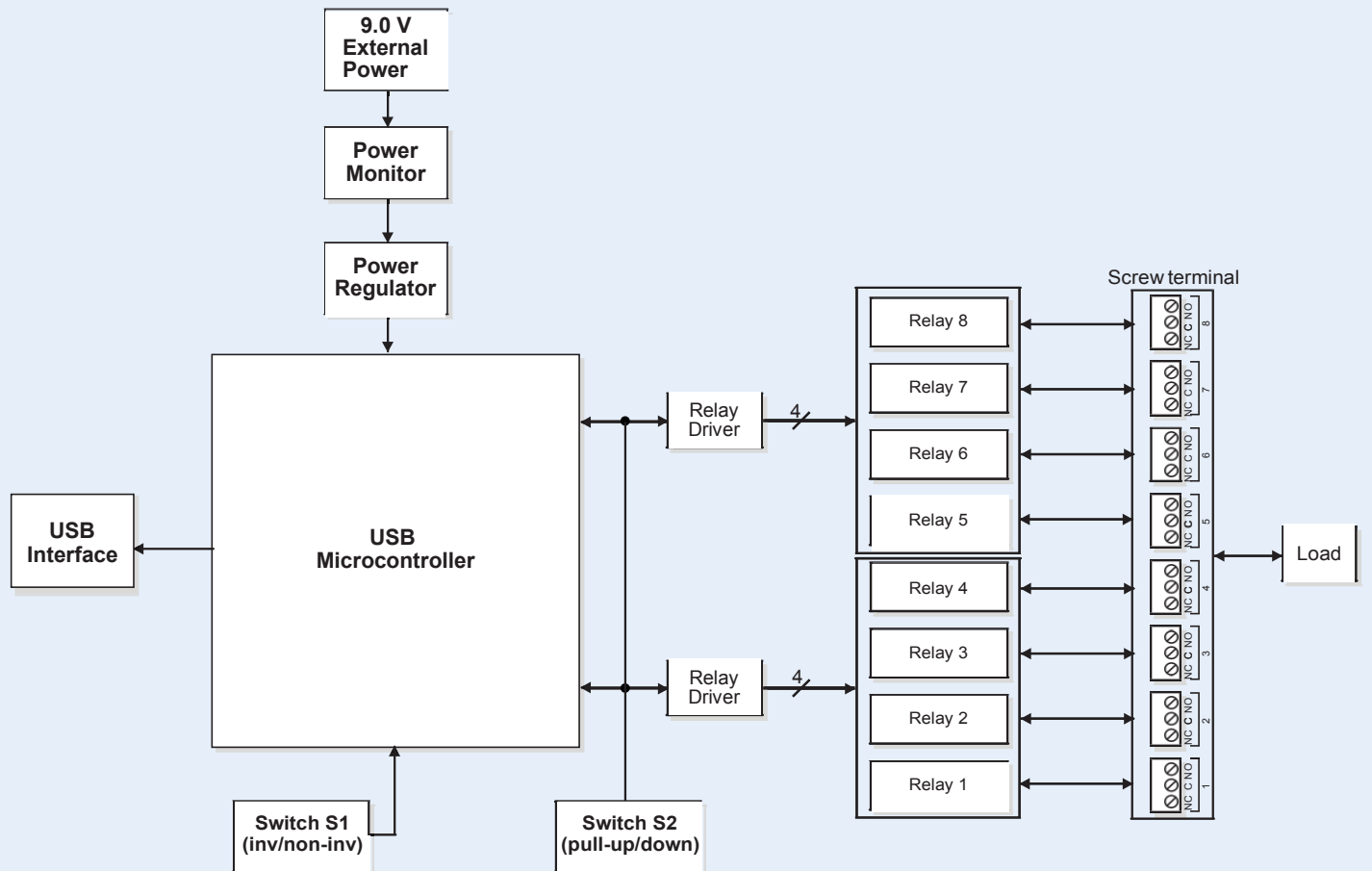

USB-ERB24 Block Diagram

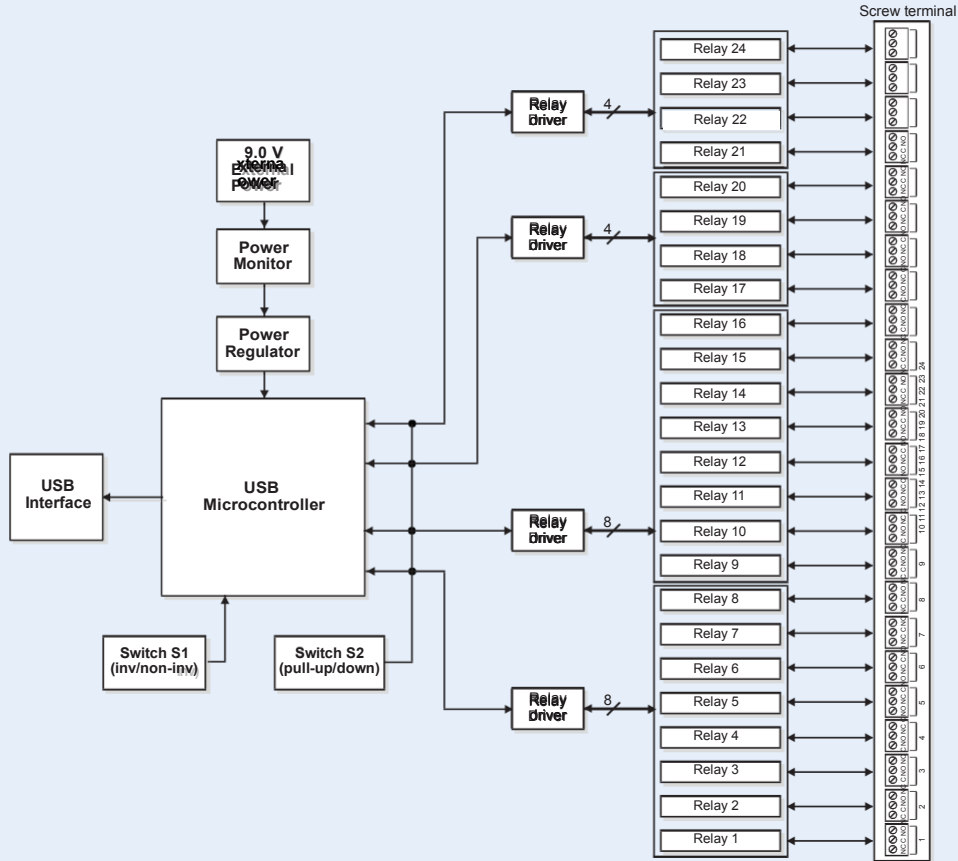

USB-ERB Series

Output Specifications

Number of relays

USB-ERB08: 8

USB-ERB24: 24

Relay configuration

USB-ERB08: 2 banks of 4

USB-ERB24: 2 banks of 8 and 2 banks of 4

Contact configuration

USB-ERB08: 8 Form C (SPDT) normally open (NO), normally closed (NC) and common (C) available at screw terminals

USB-ERB24: 24 FORM C (SPDT) NO, NC and C available at screw terminals

Contact rating: 5 A @ 240 VAC or 28 VDC resistive

Contact resistance: 100 mΩ max (initial value)

Operate time: 10 ms max

Release time: 5 ms max

Vibration: 10 Hz to 55 Hz (dual amplitude 1.5 mm)

Shock: 10 G (11ms)

Dielectric isolation

Between relay open contact: 300 VAC, 50/60 Hz (1 minute)

Between PCB output lines: 500 VAC, 50/60 Hz (1 minute)

Life expectancy: 10 million mechanical operations, min

Power on RESET state

S2 = pull-up: Energized. NO in contact with Common

S2 = pull-down: Not energized. NC in contact with Common

Relay control logic polarity: User-configurable per bank through switch S1 for invert or non-invert (default). Switch settings for polarity can be read back with software over the USB bus. Switch settings do not affect the power-on condition.

Non-invert mode: When 0 is written or read back via the USB bus, relays are not energized.

Invert mode: When 0 is written or read back via the USB bus, relays are energized.

Pull-up/pull-down (controls relay power on state): User-configurable per bank through switch S2 for pull-down (default) or pull-up. Switch settings can be read back with software.

- Pull-down puts the relays in non-energized mode on power up.

- Pull-up puts the relays in energized mode on power up.

Power

USB +5 V input voltage range: 4.75 V min to 5.25 V max

USB +5 V supply current (all modes of operation): 10 mA max

Voltage supervisor limits - PWR LED

6.0 V > Vext or Vext > 12.5 V: PWR LED = Off (power fault)

6.0 V ≤ Vext < 12.5 V: PWR LED = On

The daisy chain power output option allows multiple MCC USB Series products with a USB hub output port to be powered from a single external power source in a daisy chain fashion. The voltage drop between the device power supply input and the daisy chain output is 0.5 V max. Users must plan for this drop to assure the last device in the chain receives at least 6.0 VDC.

External power consumption

All relays on, 100 mA downstream hub power

USB-ERB08: 750 mA typ, 850 mA max

USB-ERB24: 1.5 A typ, 1.8 A max

All relays off, 100 A downstream hub power

USB-ERB08: 170 mA typ, 200 mA max

USB-ERB24: 230 mA typ, 270 mA max

USB DIO High Voltage and Relay Logicbus

Specifications - USB-ERB Series

External Power Input

External power input: +6.0 VDC to 12.5 VDC (9 VDC power supply included)

External power supply (included)

USB-ERBo8

MCC p/n CB-PWR-9: 9 V $\pm 10\%$ @ 1 A

USB-ERB24

MCC p/n CB-PWR-9V3A: 9 V $\pm 10\%$ @ 3 A

External Power Output

External power output (current range): 4.0 A max

External power output (voltage drop between power input and daisy chain power output): 0.5 V max

USB-ERB Series devices monitor the external +9 V power supply voltage with a voltage supervisory circuit. If this power supply exceeds its specified limit, the PWR LED turns off, indicating a power fault condition.

Compatible cable for daisy chain: MCC p/n C-MAPWR-x (x = 2, 3, or 6 feet)

USB Specifications

USB Type-B connector: Input

USB device type: USB 2.0 (full-speed)

Device compatibility: USB 1.1, USB 2.0

USB-ERBo8: Hardware revision E and later are also compatible with USB 3.0. The revision is indicated on the part number label on the housing – 193776X-01L – where X is the hardware revision.

USB-ERB24: Hardware revision G and later are also compatible with USB 3.0. The revision is indicated on the part number label on the housing – 193773X-01L – where X is the hardware revision.

USB Type-A connector: Downstream hub output port

USB hub type: Supports USB 2.0 high-speed, full-speed and low-speed operating points; self-powered, 100 mA max downstream VBUS capability

Compatible products: MCC USB Series devices

USB cable type (upstream and downstream): A-B cable, UL type AWM 2527 or equivalent (min 24 AWG VBUS/GND, min 28 AWG D+/D-).

USB cable length: 3 meters max.

Relay Contact Pull-Up/Down Option

Relays NO contact pull-up (to USB +5 V)/pull-down, user installed

USB-ERBo8: R1, R3, R5, R7, R10, R12, R14, R16

USB-ERB24: R35, R36, R41, R43, R45, R47, R49, R51, R87, R89, R91, R93, R96, R98, R100, R102, R103, R105, R107, R109, R112, R114, R116, R118

Relays NC contact pull-up (to USB +5 V)/pull-down, user installed

USB-ERBo8: R2, R4, R6, R8, R9, R11, R13, R15

USB-ERB24: R37, R40, R42, R44, R46, R48, R50, R52, R88, R90, R92, R94, R95, R97, R99, R101, R104, R106, R108, R110, R111, R113, R115, R117

Mechanical

USB-ERBo8 dimensions (L x W x H)

PCB: 203.2 x 121 x 20.0 mm (8.0 x 4.8 x 0.8 in.)

Enclosure: 241.3 x 125.7 x 58.9 mm (9.50 x 4.95 x 2.32 in.)

USB-ERB24 dimensions (L x W x H)

PCB: 431.8 x 121 x 20.3 mm (17.0 x 4.8 x 0.8 in.)

Enclosure: 482.6 x 125.7 x 58.9 mm (19.00 x 4.95 x 2.32 in.)

Main Connector

Connector type: Screw terminal

Wire gauge range: 12 to 22 AWG

Environmental

Operating temperature range: 0 to 70 °C

Storage temperature range: -40 to 100 °C

Humidity: 0% to 95% non-condensing

USB-SSR08 Block Diagram

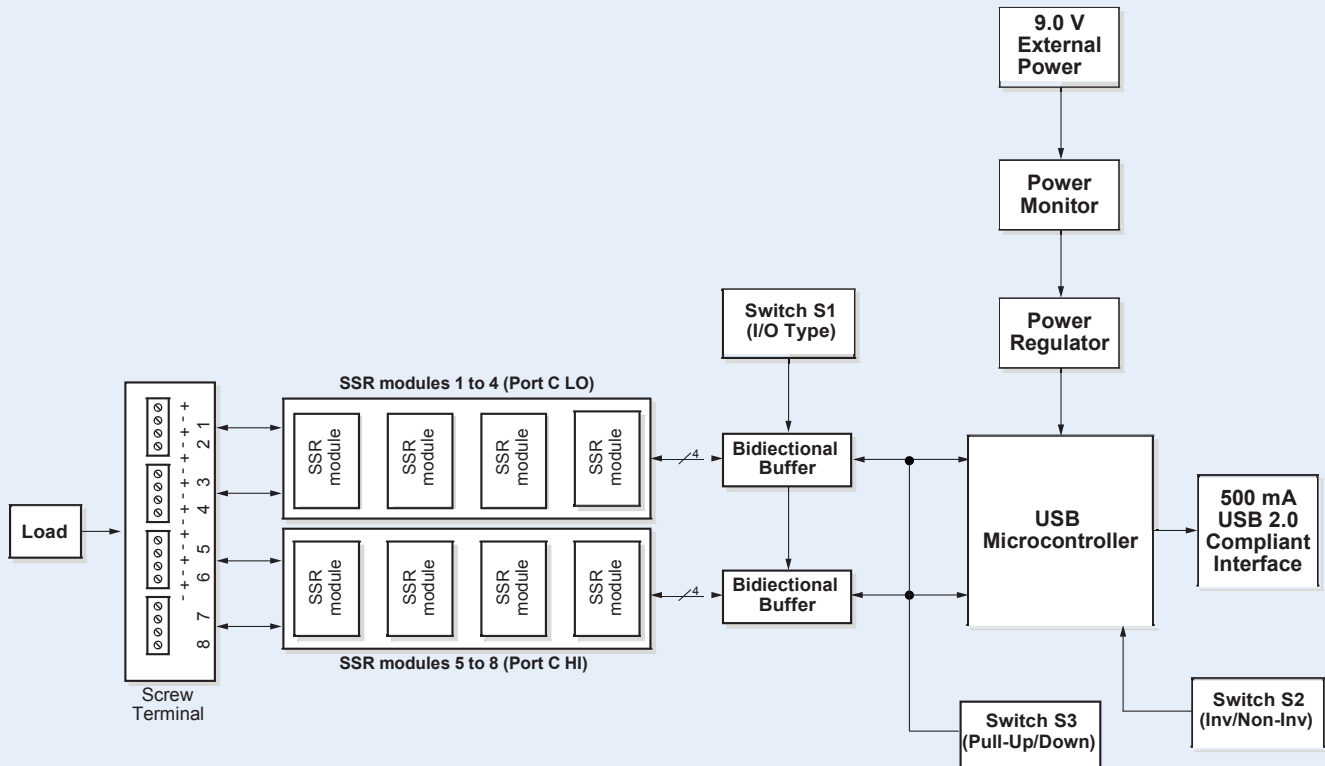

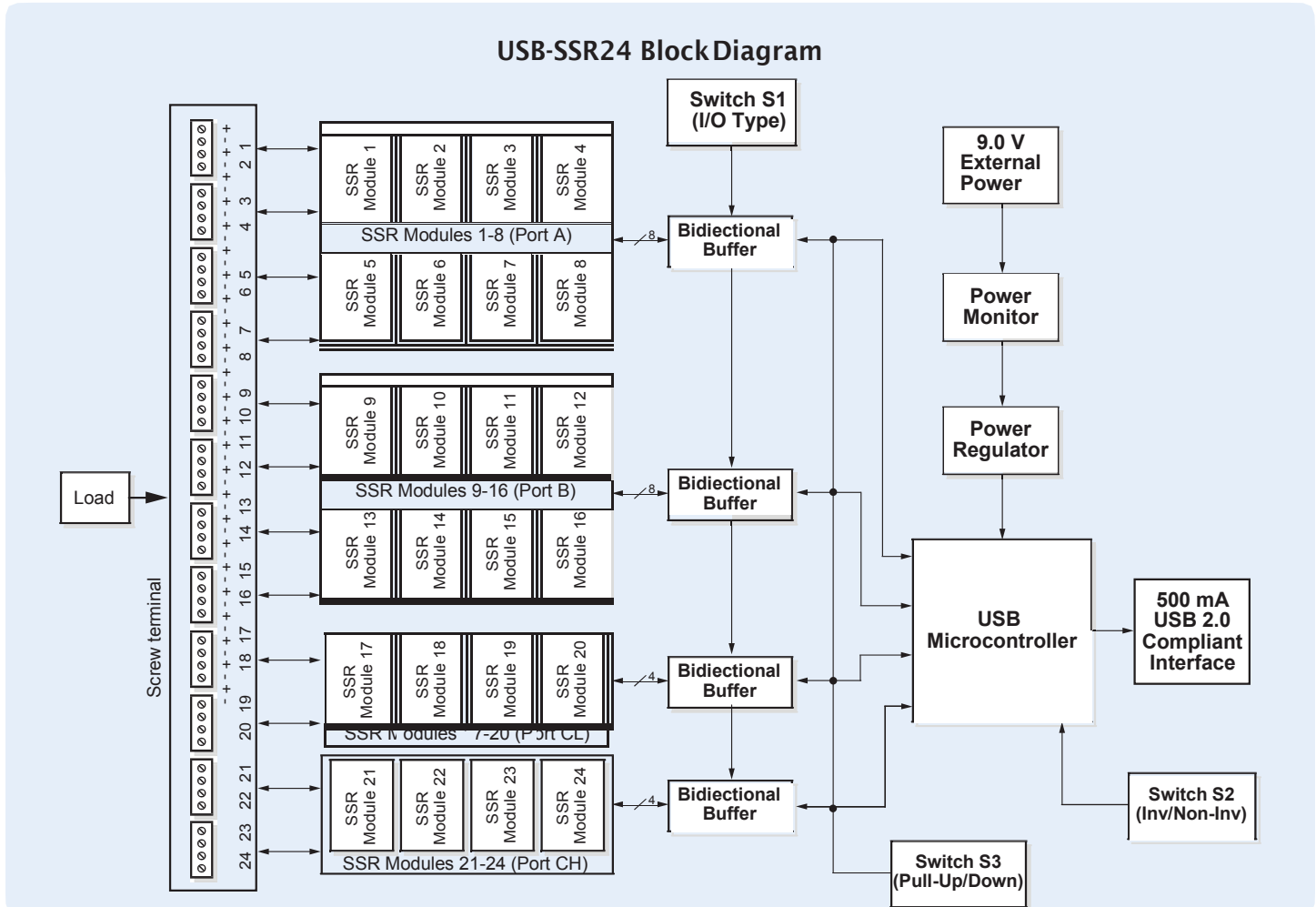

USB-SSR Series

I/O Module Configuration

USB-SSR08

Modules 1-4: Selectable with switch S1 in the *CL* position as either input or output (default) modules. Switch settings for direction can be read back with software. Do not mix input and output modules within this bank of four.

Modules 5-8: User-selectable with switch S1 in the *CH* position as either input modules or output (default) modules. Switch settings for direction can be read back with software. Do not mix input and output modules within this bank of four.

USB-SSR24

Modules 1-8: Selectable with switch S1 in the *A* position as either input or output (default) modules. Switch settings for direction can be read back with software. Do not mix input and output modules within this bank of eight.

Modules 9-16: Selectable with switch S1 in the *B* position as either input modules or output (default) modules. Switch settings for direction can be read back with software. Do not mix input and output modules within this bank of eight.

Modules 17-20: Selectable with switch S1 in the *CL* position as either input or output (default) modules. Switch settings for direction can be read back with software. Do not mix input and output modules within this bank of four.

Modules 21-24: Selectable with switch S1 in the *CH* position as either input or output (default) modules. Switch settings for direction can be read back with software. Do not mix input and output modules within this bank of four.

I/O module logic polarity: Selectable with switch S2. Switch settings for polarity can be read back with software. Default to non-inverted. For input modules, invert mode returns a *1* when module is active; non-invert mode returns a *0* when module is active. For output modules, invert mode allows users to write a *1* to activate the module; non-invert mode allows users to write a *0* to activate the module.

Pull-up/pull-down on digital I/O lines: Configurable with switch S3 with 2.2k resistor network. Switch settings for pull-up/pull-down selection can be read back with software. Default to pull-up. Switch settings are applicable during power up conditions of output modules only. Modules are active Low. When switch to Pull-up, modules are inactive on power up. When switched to pull-down, modules are active on power up.

Power

USB +5 V input voltage range: 4.75 V min to 5.25 V max

USB +5 V supply current (all modes of operation)

USB-SSR08: <100 mA

USB-SSR24: 10 mA max

External power supply (included; required for USB-SSR24): MCCP/n CB-PWR-9 9 V ±10% @ 1.0 A

Voltage supervisor limits - PWR LED

6.0 V > Vext or Vext > 12.5 V: PWR LED = Off (power fault)

6.0 V ≤ Vext < 12.5 V: PWR LED = On

USB DIO High Voltage and Relay

Specifications - USB-SSR Series

External power consumption

All modules on, 100 mA downstream hub power

USB-SSR08: 300 mA typ, 360 mA max

USB-SSR24: 800 mA typ, 950 mA max

All modules off, 0 mA downstream hub power

USB-SSR08: 180 mA typ, 220 mA max

USB-SSR24: 200 mA typ, 220 mA max

External Power Input

External power input: +6.0 VDC to 12.5 VDC (9 VDC power supply included)

External power supply (included; required for USB-SSR24)

MCC p/n CB-PWR-9: 9 V $\pm 10\%$ @ 1 A

External Power Output

External power output (current range): 4.0 A max

USB-SSR Series devices monitor the external +9 V power supply voltage with a voltage supervisory circuit. If this power supply exceeds its specified limit, the **PWR** LED turns off, indicating a power fault condition.

External power output (voltage drop between power input and daisy chain power output): 0.5 V max

The daisy chain power output option allows multiple MCC USB boards to be powered from a single external power source in a daisy chain fashion. The voltage drop between the module power supply input and the daisy chain output is 0.5 V max. Users must plan for this drop to assure the last module in the chain receives at least 6.0 VDC.

Compatible cable for daisy chain: MCC p/n C-MAPWR-x (x = 2, 3, or 6 feet)

USB Specifications

USB Type-B connector: Input

USB device type: USB 2.0 (full-speed)

Device compatibility: USB 1.1, USB 2.0

USB-SSR Series revision F and later are also compatible with USB 3.0. The revision determined from the part number label on the housing as follows:

USB-SSR08: The part number label on the housing shows as 193779X-01L, where X is the hardware revision

USB-SSR24: The part number label on the housing shows as 93782X-01L, where X is the hardware revision

USB Type-A connector: Downstream hub output port

USB hub type: Supports USB 2.0 high-speed, full-speed and low-speed operating points; self-powered, 100 mA max downstream VBUS capability

Compatible products: MCC USB Series devices

USB cable type (upstream and downstream): A-B cable, UL type AWM 2527 or equivalent (min 24 AWG VBUS/GND, min 28 AWG D+/D-).

USB cable length: 3 meters max.

Digital I/O Transfer Rates

Digital I/O transfer rate (software paced): System dependent, 33 to 1000 port reads/writes or single bit reads/writes per second typ.

Mechanical

USB-SSR08 dimensions (L x W x H)

PCB (without modules): 8.0 x 4.8 x 0.885 in. (203.2 x 121.9 x 22.5 mm)

Enclosure: 9.50 x 4.95 x 2.32 in. (241.3 x 125.7 x 58.9 mm)

USB-SSR24 dimensions (L x W x H)

PCB (without modules): 431.8 x 121.9 x 22.5 mm (17.0 x 4.8 x 0.885 in.)

Enclosure: 482.6 x 125.7 x 58.9 mm (19.00 x 4.95 x 2.32 in.)

Main connector

Connector type: Screw terminal

Wire gauge range: 12 to 22 AWG

SSR Digital I/O Modules

Specifications for the SSR modules available for the USB-SSR Series are listed below.

Digital Input Sensing Modules

MCC part number	Input type	Isolation voltage	Input voltage range	Input current @ max line	Turn-on time	Turn-off time
SSR-IAC-05	AC	4000 Vrms	90-140 VAC/DC	8 mA	20 ms	20 ms
SSR-IAC-05A	High voltage AC	4000 Vrms	180-280 VAC/DC	6 mA	20 ms	20 ms
SSR-IDC-05	DC	4000 Vrms	3-32 VDC	18 mA	0.20 ms	0.40 ms
SSR-IDC-05NP	Non-polarized, AC or DC	4000 Vrms	15-32 VAC, 10-32 VDC	18 mA	5 ms	5 ms

Digital Output Switching Modules

MCC part number	Output type*	Isolation voltage	Load voltage range	Load current range	Turn-on time	Turn-off time
SSR-OAC-05	AC	4000 Vrms	24-140 VAC	0.03-3.5 A	8.33 ms	8.33 ms
SSR-OAC-05A	AC	4000 Vrms	24-280 VAC	0.03-3.5 A	8.33 ms	8.33 ms
SSR-ODC-05	DC	4000 Vrms	3-60 VDC	0.02-3.5 A	20 μ s	50 μ s
SSR-ODC-05A	DC	4000 Vrms	4-200 VDC	0.02-3.5 A	75 μ s	750 μ s

* SPST, normally open

USB DIO High Voltage and Relay

Ordering

Order Information

Hardware

Part No.	Description
USB-PDISO8	USB-based eight Form C relay and eight isolated high-voltage input interface device. Includes power supply and USB cable.
USB-PDISO8/40	USB-based eight Form C Relay and eight isolated high-voltage input interface device with 40-pin connector. Includes power supply and USB cable.
USB-SSR08	USB-based solid-state eight I/O module interface device. Includes power supply and USB cable.
USB-SSR24	USB-based solid-state 24 I/O module interface device. Includes power supply and USB cable.
USB-ERB08	USB-based 8-channel electromechanical relay interface device. Includes power supply and USB cable.
USB-ERB24	USB-based 24-channel electromechanical relay interface device. Includes power supply and USB cable.

Accessories and Cables

Part No.	Description
CB-PWR-9	Replacement power supply, 9 V, for USB-PDISO8 Series, USB-SSR Series, and USB-ERB08 – non-interchangeable US plug
CB-PWR-9V3A	Replacement power supply, 9 V, for USB-ERB24
PS-9V1AEP5230V	Replacement 230 V power supply, 9 V output, for USB-PDISO8 Series, USB-SSR Series, and USB-ERB08 – interchangeable plugs available separately
C-MAPWR-x	Cable, daisy-chain, power, for USB devices with built-in expansion ports – x = 2, 3, or 6 ft.
CIO-MINI40	Universal screw-terminal board, 37-pin

SSR Digital I/O Modules (USB-SSR Series Only)

Part No.	Description
SSR-IAC-05	AC sense input module, 90 to 140 VAC/VDC
SSR-IAC-05A	AC sense input module, 180 to 280 VAC/VDC
SSR-IDC-05	DC sense input module, 3 to 32 VDC
SSR-IDC-05NP	DC sense input module, 10 to 32 VDC non-polarized
SSR-OAC-05	AC switch output module, 24 to 140 VAC, 3.5 A @ 120 VAC, SPST normally open
SSR-OAC-05A	AC switch output module, 24 to 280 VAC, 3.5 A @ 240 VAC, SPST normally open
SSR-ODC-05	DC switch output module, 3 to 60 VDC @ 3.5 A, SPST normally open
SSR-ODC-05A	DC switch output module, 4 to 200 VDC @ 3.5 A, SPST normally open

Software also Available from MCC

Part No.	Description
DAQami	Easy-to-use advanced data logging application to acquire, view, and log data
TracerDAQ Pro*	Out-of-the-box virtual instrument suite with strip chart, oscilloscope, function generator, and rate generator – professional version
DASYLab	Icon-based data acquisition, graphics, control, and analysis software

* TracerDAQ Pro only supports USB-PDISO8 Series digital inputs; it does not support USB-ERB Series or USB-SSR Series devices.