

T. Pressure Transmitters



T. Overview of pressure transmitters

Technical explanations
for pressure transmitters

from page 138

Selection matrix

A guide to choosing the correct pressure transmitter

from page 143

Pressure Transmitters with ceramic measuring cell



T.1

T.1 Pressure transmitters, Performance series, hex 24

from page 144

Standard pressure ranges: 0 – 2 bar (0-14 psi), 0 – 4 bar (0-58 psi), 0 – 10 bar (0-145 psi), 0 – 16 bar (0-232 psi)
0 – 40 bar (0-580 psi), 0 – 100 bar (0-1,540 psi), 0 – 250 bar (0-3,625 psi)

Overpressure protection: 2x

Output signal (alternative): 0 – 10 V or 4 – 20 mA

Housing materials: Stainless steel 1.4305 (AISI 303)

Sealing materials: NBR, EPDM, FKM, TPE

Threads: BSPP 1/4 E, NPT 1/4

Types: 0601, 0602

Pressure Transmitters with oil-filled measuring cell



T.2

T.2 Robust pressure transmitter, hex 22,
stainless steel „303“

from page 148

Standard pressure ranges: **-1 – 0 bar (vacuum), -1 – 1 bar (compound)**
0 – 1 bar (0-14 psi), 0 – 4 bar (0-58 psi), 0 – 6 bar (0-87 psi), 0 – 10 bar (0-145 psi)
0 – 16 bar (0-232 psi), 0 – 40 bar (0-580 psi), 0 – 100 bar (0-1,450 psi)

Overpressure protection: 2x

Output signal (alternative): 0.5 – 4.5 V ratiometric or 0 – 10 V or
4 – 20 mA

Housing materials: Stainless steel 1.4305 (AISI 303)

Sealing materials: NBR, EPDM, FKM

Thread: BSPP 1/4 E

Types: 0645, 0650, 0660



T.3

T.3 Robust pressure transmitter, hex 22,
stainless steel „316L“

from page 152

Standard pressure ranges: **-1 – 0 bar (vacuum), -1 – 1 bar (compound)**
0 – 1 bar (0-14 psi), 0 – 4 bar (0-58 psi), 0 – 6 bar (0-87 psi), 0 – 10 bar (0-145 psi)
0 – 16 bar (0-232 psi), 0 – 40 bar (0-580 psi), 0 – 100 bar (0-1,450 psi)

Overpressure protection: 2x

Output signal (alternative): 0.5 – 4.5 V ratiometric or 0 – 10 V or
4 – 20 mA

Housing materials: Stainless steel 1.4404 (AISI 316L)

Sealing materials: NBR, EPDM, FKM

Thread: BSPP 1/4 E

Types: 0675, 0680, 0690

Pressure Transmitters with SoS technology



T.4 Pressure transmitters, High-Performance series, hex 22 from page 156

Standard pressure ranges: 0 - 1 bar (0-14 psi), 0 - 2.5 bar (0-36 psi), 0 - 4 bar (0-58 psi), 0 - 6 bar (0-87 psi)
 0 - 60 bar (0-870 psi), 0 - 100 bar (0-1,450 psi), 0 - 160 bar (0-2,320 psi)
 0 - 250 bar (0-3,625 psi), 0 - 400 bar (0-5,800 psi), 0 - 600 bar (0-8,700 psi)

Overpressure protection: **Up to 4 x**
 Output signal (alternative): 0.5 – 4.5 V ratiometric or
 0 – 10 V or
 4 – 20 mA

Housing materials: Stainless steel 1.4305 (AISI 303)
 Sealing materials: **All welded, without elastomeric seal**
 Thread: different male threads
 Types: 0705, 0710, 0720



Pressure Transmitters with CAN-Bus interface

CAN J1939

CANopen

T.5 Digital pressure transmitters, CANopen / J1939-Protocol, hex 22 from page 160

Standard pressure ranges: 0 - 1 bar (0-14 psi), 0 - 2.5 bar (0-36 psi), 0 - 4 bar (0-58 psi), 0 - 6 bar (0-87 psi)
 0 - 10 bar (0-145 psi), 0 - 16 bar (0-232 psi), 0 - 25 bar (0-362 psi), 0 - 40 bar (0-580 psi)
 0 - 60 bar (0-870 psi), 0 - 100 bar (0-1,450 psi), 0 - 160 bar (0-2,320 psi)
 0 - 250 bar (0-3,625 psi), 0 - 400 bar (0-5,800 psi), 0 - 600 bar (0-8,700 psi)

Overpressure protection: **Up to 2 x**
 Output protocol: **CANopen** DIN EN 50325-4
CAN J1939 SAE J1939

Housing materials: Stainless steel 1.4301 / AISI 304
 Sealing materials: **All welded, without elastomeric seal**
 Electrical connection: M12 DIN EN 61076-2-101 A,
 CiA-DR303-1
 Thread: BSPP 1/4 E, NPT 1/4
 Types: 0630, 0631



T.6 Accessories from page 164

- Mating plugs
- Thread-Adapters
- Display



Technical explanations for pressure transmitters

What is a pressure transmitter?

A pressure transmitter (also called pressure transducer or pressure converter) is a component used to convert a pneumatic or hydraulic pressure to an electric (usually analogue and linear) output signal, such as a current or voltage.

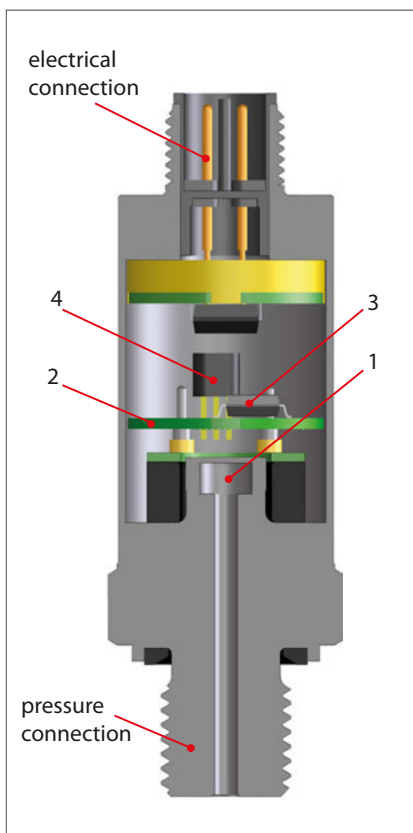

How does a pressure transmitter work?

The pressure measuring cell fitted has a membrane (1) that is exposed to the pressure to be measured. Affixed on this membrane is a bridge circuit consisting of four ohmic resistors in the form of a Wheatstone bridge. The values of these resistors change proportionally to the pressure load present at the measuring cell or membrane. The bridge voltage of the measuring cell is amplified in the evaluation electronics (2) and processed digitally by a microcontroller (3).

The downstream output stage (4) converts this signal to the output signal required (such as 4 - 20 mA or 0 - 10V).

SoS technology

In the silicone-on-sapphire technology, the substrate of the thin film measuring cell is synthetic sapphire. This has excellent mechanical and temperature stable properties and prevents undesired parasitic effects, thereby having a positive effect on accuracy and stability. In conjunction with a titanium membrane, this results in virtually unique coaction between the temperature coefficients of sapphire and titanium.

This is because, unlike silicon and stainless steel, they are more closely matched and so only require a low level of compensation overhead. This also has a favourable effect on long-term stability.

„Oil-filled“ stainless steel measuring cell

In this measuring cell technology, the piezoresistive measuring cell is packaged within a metallic housing filled with fluorine oil. This means the measuring cell is virtually free of external mechanical stress. Fluorine oil has excellent characteristics in regards to temperature and ageing behaviour, and is not flammable and so fits perfectly to oxygen applications. It is not recommended for food applications.

Ceramic measuring cell / thick film technology

Ceramic thick film pressure measuring cells are made up of a sintered ceramic body. The ceramic body sleeve already has the key geometries for the subsequent pressure range. The membrane thickness required and thus, the pressure range required is established with grinding and lapping. The resistors are imprinted with thick film technology and interconnect to form a measuring bridge.

Standard signals

Output signals 4 - 20 mA, 0 - 10 V and 0.5 - 4.5 V ratiometric in particular have established themselves in the industry. SUCO also offers transmitters with customer-specific output signals (such as 1 - 5 V).

Block diagram:

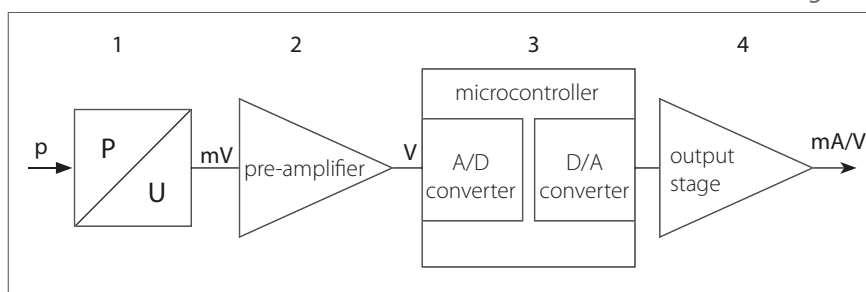

Voltage output 0 - 10 V

Transmitters with an output signal of 0 to 10 V are a commonly used variant due to their simple initial operation and straight-forward scaling of the signal (0 V for 0 bar). The output load must be selected as highly resistive (with typical minimum value 4.7 kΩ). SUCO transmitters with voltage output have a 3-wire design.

The maximum connection length should not exceed 30 m to prevent significant voltage drops in the signal line.

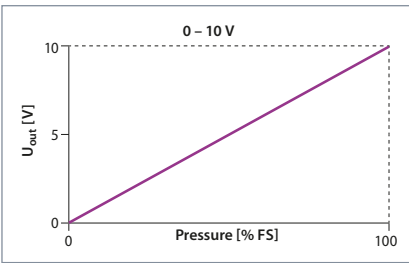

Conversion formula for pressure and voltage:

$$U_{out} = \frac{\text{pressure applied}}{\text{pressure range}} \times 10 \text{ V}$$

Voltage output

0.5 – 4.5 V ratiometric

SUCO transmitters with ratiometric output are operated with a 5 V supply voltage as 3-wire configuration. The output signal is directly proportional to / dependent on the supply voltage; this is known as a ratiometric dependency. 0.5 – 4.5 V is established as an output voltage because many A/D converters work with reference voltage U_{v+} of 5 V. The output voltage 0.5 V equals to 10% and 4.5 V corresponds to 90% of the supply voltage. The span is therefore 80% of the supply voltage.

This variant is used for example when a transmitter and a downstream A/D converter as an evaluation unit are to be powered with the same reference / operating voltage.

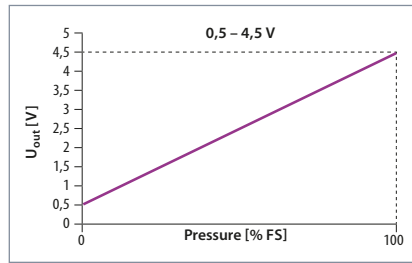

Conversion formula for pressure and voltage:

$$U_{out} = 0.1 \times U_{v+} + \frac{\text{pressure applied}}{\text{pressure range}} \times 0.8 \times U_{v+}$$

with U_{v+} = operating voltage

Current output 4 – 20 mA

The most common analogue output signal of sensors is 4 – 20 mA current output (as 2-wire configuration). The advantage of a 4 – 20 mA output signal is the 4 mA offset which allows the monitoring of potential wire break and short-circuit (life zero signal).

The signal can also be transmitted over long distances with no loss in accuracy. This variant is also the least sensitive to EMC factors. 2-wire technology also means wiring overhead is reduced.

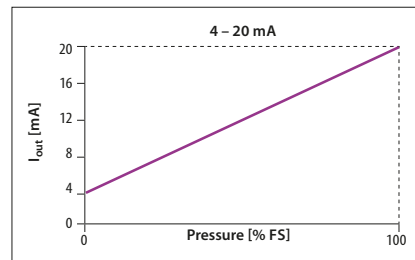

Conversion formula for pressure and voltage:

$$I_{out} = 4 \text{ mA} + \frac{\text{pressure applied}}{\text{pressure range}} \times 16 \text{ mA}$$

Output for vacuum transmitters

As depicted in the sketch on the upper right, the output is at maximum signal at zero pressure. Therefore at maximum vacuum the output signal is at its minimum.

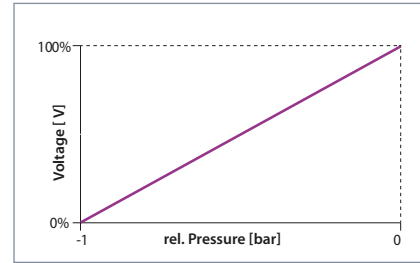

Load / apparent ohmic resistance for pressure transmitters

An appropriate ohmic load must be connected to guarantee perfect functioning of a pressure transmitter.

For transmitters with a voltage output (V), the load should be at least 4.7 kΩ.

For transmitters with a current output (4-20 mA), the maximum load is calculated using the following formula:

$$R_L = \frac{U_{v+} - U_{v+(min)}}{20 \text{ mA}}$$

$U_{v+(min)}$ is the minimum supply voltage - to be taken from the data sheet. $U_{v+(min)} = 10 \text{ V}$ gives the following operating range for example:

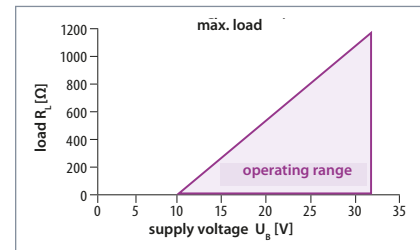

Supply / operating voltage UB

All pressure transmitters work with DC voltage and have no galvanic isolation. Within the thresholds specified in the relevant data sheet, the supply voltage may change without influencing the output signal. (the ratiometric variant is an exception).

To guarantee the functionality of a transmitter, the minimum supply voltage may not fall below. The maximum operating voltage may not be exceeded to avoid damage on the electronics.

Technical explanations for pressure transmitters

Accuracy (to DIN EN 61298)

The (measuring) accuracy of pressure transmitters is specified by SUCO as $\pm 0.5\%$ or $\pm 1\%$ of the span (also called full scale). Accuracy includes zero point offset, non-linearity, hysteresis and non-repeatability, and is defined at room temperature and new state. This method defines the maximum deviation from the ideal line (in contrast to the BFSL method in which the average deviation is given). Other factors influencing the total accuracy, such as temperature and ageing, are specified separately.

Non-linearity (to DIN EN 61298)

Non-linearity (also linearity) defines the deviation of the actual output curve from the theoretical ideal line. SUCO specifies the maximum error in relation to the overall span or full scale (FS) of the pressure range.

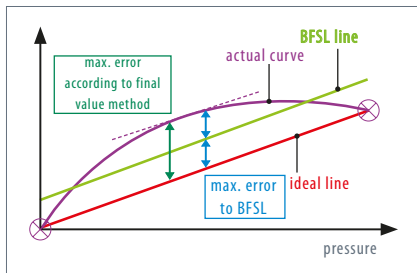

Non-linearity is also shown as BFSL (Best Fit Straight Line) as a reference value in the technical specifications. Non-linearity generally has the biggest influence on the overall error rate. Typically, non-linearity as per BFSL corresponds to half of non-linearity as per the full scale method ($1\% \text{ FS} \sim 0.5\% \text{ BFSL}$).

Hysteresis (to DIN EN 61298)

For a pressure transmitter, hysteresis specifies the difference of output signal between a rising and falling pressure, and is typically very low and negligible for SUCO pressure transmitters.

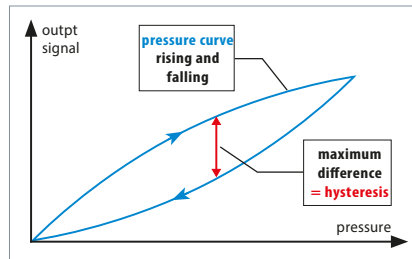

Non-repeatability (to DIN EN 61298)

Non-repeatability defines reproducibility of the output signal. The pressure is attained three times for example - the maximum variance between these three values gives the non-repeatability.

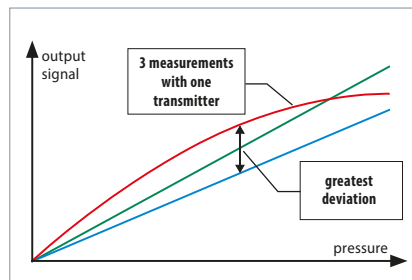

Temperature errors and ranges

The temperature (both of the medium and ambience) generally has a significant influence on the accuracy of a pressure transmitter. Pressure transmitters are temperature compensated over a particular range corresponding to the typical application. This means that temperature errors within this temperature range are minimised by means of circuitry design and algorithms. The temperature error is added to the accuracy, and shown in the total error band of the pressure transmitter, also called butterfly graph. Outside the compensated temperature range, the maximum error is not defined, however the pressure transmitter still functions.

To prevent mechanical and electrical damage, pressure transmitters may not be deployed beyond the threshold temperature ranges specified in the data sheet.

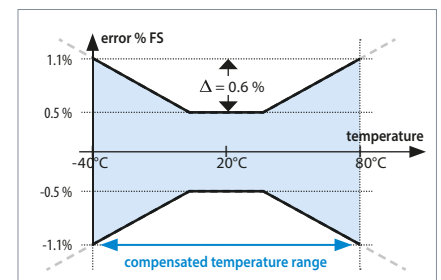

Service life and long-term stability

Service life information pertains to nominal conditions specified in the data sheet, and can vary considerably when a product is operated mechanically or electrically outside the specifications. Service life essentially depends on the used measuring cell technology.

Ageing is accelerated (or slowed) due to different factors - such as temperature, temperature change and reduction of mechanical forces. The occurrence of ageing does effect the total accuracy.

SUCO specifies long-term stability in accordance with DIN 16086 in relation to one year. Typically the influence of aging on the accuracy reduces with increasing operating duration. The information in the data sheet corresponds to the worst case scenario.

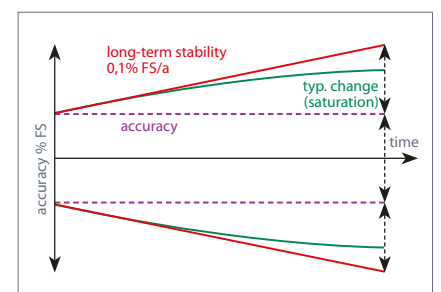

Resolution

The A/D resolution (analogue - digital) of an pressure transmitter defines the smallest change of the analogue – digital – analogue conversion which takes places by the signal processing of an pressure transmitter.

If for example 13-bit resolution is used for an pressure transmitter with a 100 bar setting range, the smallest signal change is 8192 steps (2^{13}). As state of the art a resolution of 12 bits and hence 4096 steps (2^{12}) is typical. Therefore pressure changes of $100 \text{ bar} / 4096 = 0.024 \text{ bar}$ can be recorded.

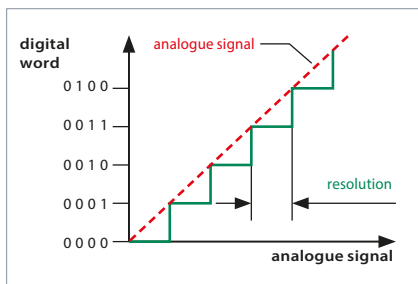

Sampling rate

The sampling rate (or sampling frequency) defines the number of samples per time unit (typically in seconds or milliseconds) taken from an analogue signal and converted to a digital signal. The sampling rate is an indicator of how fast the output signal of a pressure transmitter responds to the pressure change at the input.

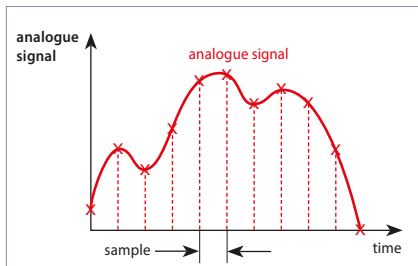

Response time

The response or circuit time is shorter than 2 to 4 milliseconds (depending on model). The sum of A/D and D/A conversions, and the analogue and digital filters in the signal chain from the measuring bridge to the output, make up the response time. Filtering is used to suppress unwanted pressure peaks and electrical interference signals, and for good EMC characteristics.

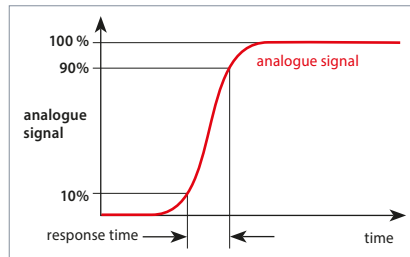

CE mark

Pressure transmitters from SUCO fall under the 2014/30/EU EMC Directive.

EC declarations of conformity have been issued for the pressure transmitters are available on request or can be downloaded from our website. The relevant devices are denoted by a CE mark in our catalogue.

The Machinery Directive 2006/42 EC is not applicable, because our products are classed as components. Our products are designed for Group 2 fluids based upon good engineering practise in line with Pressure Equipment Directive 2014/68/EU, meaning neither a declaration of conformation may be issued nor a CE mark affixed.

Electromagnetic compatibility (EMC)

Pressure transmitters from SUCO do comply to all important industrial EMC standards. The basis for the standards are the stricter thresholds for transient emissions in residential environments (EN 61000-6-3) and immunity for industrial environments (EN 61000-6-2).

Generic standard	Test standard	Parameter(s)
Radio disturbance and immunity	EN 55016-2-1 EN 55016-2-3	60 dBuV
Radiated, high-frequency electromagnetic field immunity test	EN 61000-4-3	10 V/m; 80-1000 MHz, 3 V/m; 1400-2000 MHz, 1 V/m; 2000-2700 MHz
Immunity to conducted disturbances, induced by radio-frequency fields	EN 61000-4-6	10 V; 0,15-80 MHz
Electrical fast transient / burst immunity test	EN 61000-4-4	±2 kV
Surge immunity test	EN 61000-4-5	±0,5 kV (common) ±0,5 kV (differential)
Electrostatic discharge (ESD) immunity test	EN 61000-4-2	air: 8 kV with contact: 4 kV



Technical explanations for pressure transmitters

Conversion chart for pressure units

Abbreviation for unit	Name of unit	Pa = N/m ²	bar	Torr	lbf/in ² , PSI
1 Pa = N/m ²	Pascal	1	0.00001	0.0075	0.00014
1 bar	Bar	100 000	1	750.062	14.5
1 Torr = 1 mmHg	Millimeters of mercury	133.322	0.00133	1	0.01934
1 lbf/in ² = 1 PSI	Pound-force per square inch	6894	0.06894	51.71	1

Conversion chart for temperature units

	K	°C	F
K	1	K - 273.15	9/5 K - 459.67
°C	°C + 273.15	1	9/5 °C + 32
F	5/9 (F + 459.67)	5/9 (F - 32)	1

Insulation strength

According to the latest specifications for immunity to surges and lightning protection, the following must be taken into account when testing insulation strength: With insulation test devices having an inner resistance exceeding 42 Ω, the insulation strength of pressure transmitters can be tested up to 500 VDC.

All contacts must be tested short-circuited against the housing. For a specific threshold value of test voltage, the protective circuit for surge protection is activated without any defects arising within the circuit. In the process, the current may rise to a point at which an insulation strength fault is indicated. The recommendation therefore is to conduct the insulation test of the pressure transmitter when it is removed, or independently of the overall system.

Medium compatibility

The specifications on medium compatibility in this catalogue pertain to the specific seal and housing materials as well as the used measuring cell technology and so cannot be generalised.

Stainless steel (1.4301 / AISI 304)

Stainless steel with broad level of media compatibility, such as water, steam, humidity and weak organic and inorganic acids

Stainless steel (1.4305 / AISI 303)

Stainless steel with broad level of media compatibility. Also suitable for oxygen and hydrogen applications.

Stainless steel (1.4404 / AISI 316L)

Stainless steel with broad level of media compatibility. Also suitable for chemical industry and sea water applications.

Titanium

Its high levels of mechanical resistance and the wide media compatibility – in particular to corrosive media – do make titanium the ideal material for measuring cells and membranes. It is not recommended for oxygen or hydrogen applications.

Oxygen and hydrogen

It is recommended to use an EPDM seal for the media oxygen / hydrogen to be monitored.

The EPDM seal of the „Performance“ series (pp. 144-147) was successfully tested at the BAM (Federal Institute for Materials Testing) up to 250 bar by means of an oxygen pressure shock test at 60 °C.

EPDM must not come into contact with oil, as this results in swelling and softening of the material and thus the failure of the transmitter.

Country-specific safety requirements and application guidelines must be observed if the medium to be monitored is oxygen or hydrogen, such as DGUV accident prevention regulations (DGUV 500, Section 2.32 and BGI 617).

Please specify when ordering „for oxygen, oil and grease-free“ or order plasma cleaned and individually packaged transmitters (see also „Plasma cleaning for oxygen applications / LABS-free (PWIS-free)“ on page 9).

Pressure peak dampening

If required, our pressure transmitters can also be fitted with a pressure snubber (pressure peak orifice) to protect the measuring cell against transient pressure loads such as pressure peaks due to the switching of valves, cavitation effects, etc. which can shorten life expectancy.

For liquid media, the hole of a pressure snubber cannot be chosen to be any small size. At low temperatures the viscosity of the media will increase. In a case of dropping pressure the media might remain in the cavity behind the snubber which might affect the functionality of the pressure transmitter. Thus a bore diameter of 0.8 mm has been established.

Product information

The technical information in this catalogue is based upon fundamental testing during product development, as well as upon empirical values. The information cannot be used for all application scenarios.

Testing of the suitability of our products for a specific application (e.g. also the checking of material compatibilities) falls under the responsibility of the user. It may be the case that suitability can only be guaranteed with appropriate field testing.

Subject to technical changes.

Selection matrix for pressure transmitters

Type / series		0601	0602	0645	0650	0660	0675	0680	0690	0705	0710	0720	0630	0631
Page		147	147	151	151	151	155	155	155	159	159	159	163	163
Measuring cell technology	stainless steel, oilfilled, piezo-resistive			■	■	■	■	■	■					
	stainless steel, piezo-resistive												■	■
	ceramic / thick-film	■	■											
	SoS / titanim									■	■	■		
Function	overpressure	■	■	■	■	■	■	■	■	■	■	■	■	■
	vacuum			■	■	■	■	■	■					
Output	0.5 - 4.5 V ratiometric			■			■			■				
	0 - 10 V	■			■			■			■			
	4 - 20 mA		■			■			■			■		
	CAN												■	■
Operating voltage	5 VDC ± 10 %			■			■			■				
	(9.6 ... 12) - 32 VDC	■	■		■	■		■	■		■	■	■	■
Pressure range	-1 - 0 bar (-14 _ 0 psi)			■	■	■	■	■	■					
	-1 - 1 bar (-14 _ 14 psi) (compound)			■	■	■	■	■	■					
	0 - 1 bar (0 - 14 psi)			■	■	■	■	■	■				■	■
	0 - 2 bar (0-29 psi)	■	■											
	0 - 2.5 bar (0-36.26 psi)												■	■
	0 - 4 bar (0-58 psi)	■	■	■	■	■	■	■	■	■			■	■
	0 - 6 bar (0-87 psi)			■	■	■	■	■	■	■			■	■
	0 - 10 bar (0-145 psi)	■	■	■	■	■	■	■	■	■	■	■	■	■
	0 - 16 bar (0-232 psi)	■	■	■	■	■	■	■	■	■	■	■	■	■
	0 - 25 bar (0-362 psi)									■	■	■	■	■
	0 - 40 bar (0-580 psi)	■	■	■	■	■	■	■	■	■	■	■	■	■
	0 - 60 bar (0-870 psi)									■	■	■	■	■
	0 - 100 bar (0-1,450 psi)	■	■	■	■	■	■	■	■	■	■	■	■	■
	0 - 160 bar (0-2,320 psi)									■	■	■	■	■
	0 - 250 bar (0-3,626 psi)	■	■							■	■	■	■	■
	0 - 400 bar (0-5,800 psi)									■	■	■	■	■
	0 - 600 bar (0-8,702 psi)									■	■	■	■	■
Overpressure protection	up to 2x	■	■	■									■	■
	up tp 3x			■	■	■	■	■	■					
	up to 4x									■	■	■		
Compensated temperature range	0... +158 °F (0 ... +70 °C)	■	■											
	14... +158 °F (-10 ... +70 °C)			■	■	■	■	■	■					
	-4... +185 °F (-20 ... +85 °C)												■	■
	-40... +176 °F (-40 ... +80 °C)									■	■	■		
Size	hex 22			■	■	■	■	■	■	■	■	■	■	■
	hex 24	■	■											
Housing material	stainless steel 1.4201 / AISI 304												■	■
	stainless stell 1.4305 / AISI 303	■	■	■	■	■				■	■	■		
	stainless steel 1.4404 / AISI 316L						■	■	■					
Option	suitable for oxygen (on request)	■	■	■	■	■	■	■	■					



T.1

hex 24

Performance

Pressure transmitters, Performance series

hex 24



- Very attractively priced electronic pressure transmitters
- High overpressure protection (up to 2 x)
- Small, compact transmitters
- High level of adaptability to your requirements (custom solutions)
- Ceramic sensor in thick film technology
- Housing made of stainless steel (1.4305), others on request
- Available as 'plasma cleaned for oxygen applications'¹⁾

¹⁾ For oxygen applications, the EPDM diaphragm can only be used up to 250 bar and a media temperature of max. +60°C.

Pressure transmitters, Performance series

Technical details

Type:	0601	0602
Output signal:	0 – 10 V (3-wire)	4 – 20 mA (2-wire)
Supply voltage U_{V+} :	11 - 32 VDC with reverse voltage protection	9.6 - 32 VDC with reverse voltage protection
Permissible load apparent ohmic resistance:	$\geq 4.7 \text{ k}\Omega$	$\leq (U_{V+} - 10 \text{ V}) / 20 \text{ mA}$
Idle power consumption:	approx. 5 mA	< 4 mA

Type:	0601 / 0602						
Standard pressure ranges p_{nom} :	0 - 2 bar (0 - 29 psi)	0 - 4 bar (0 - 58 psi)	0 - 10 bar (0 - 145 psi)	0 - 16 bar (0 - 230 psi)	0 - 40 bar (0 - 580 psi)	0 - 100 bar (0 - 1,450 psi)	0 - 250 bar (0 - 3,625 psi)
Overpressure protection p_u^1 :	4 bar (58 psi)	10 bar (145 psi)	20 bar (290 psi)	40 bar (580 psi)	100 bar (1,450 psi)	150 bar (2,175 psi)	375 bar (5,439 psi)
Burst pressure: ¹⁾	8 bar (115 psi)	20 bar (290 psi)	35 bar (500 psi)	60 bar (870 psi)	140 bar (2,000 psi)	300 bar (4,350 psi)	500 bar (7,250 psi)
Mechanical life expectancy:	5,000,000 pulsations at rise rates to 14,500 psi/s (1,000 bar/s) at p_{nom}						
Permitted pressure change rate:	$\leq 14,500 \text{ psi/s}$ ($\leq 1,000 \text{ bar/s}$)						
Accuracy:	$\leq \pm 1 \%$ full scale (FS) at room temperature, $\pm 0.5 \%$ BFSL						
Long term stability:	$\pm 0.3 \%$ of full scale (FS) per year						
Repeatability: ²⁾	$\pm 0.1 \%$ FS						
Temperature error ³⁾ :	$\leq \pm 0.04 \%$ of full scale (FS) / °C						
Compensated temperature range:	32 °F ... +158 °F (0 °C ... +70 °C)						
Temperature range ambient:	-22 °F ... +212 °F (-30 °C ... +100 °C)						
Temperature range media:	with NBR (BunaN) seal: -22 °F ... +212 °F (-30 °C ... +100 °C)						
	with EPDM seal: -22 °F ... +257 °F (-30 °C ... +125 °C)						
	with FKM (Viton®) seal: -4 °F ... +257 °F (-20 °C ... +125 °C)						
	with TPE seal: -22 °F ... +230 °F (-30 °C ... +110 °C)						
Wetted parts material	Housing:	Stainless steel AISI 303 (1.4305)					
	Measuring cell:	Ceramic					
	Seal material:	NBR (BunaN), EPDM, FKM (Viton®) ³⁾ or TPE					
Insulation resistance:	> 100 M Ω (35 VDC)						
Response time 10 – 90 %:	$\leq 2 \text{ ms}$						
Vibration resistance:	20 g; at 4 ... 2000 Hz sine wave; DIN EN 60068-2-6						
Shock resistance:	half sine wave 500 m/s ² ; 11 ms; DIN EN 60068-2-27						
Protection class	IP65: DIN EN 175301-803-A, IP67: M12x1, AMP Superseal 1.5°, cable connector IP67 and IP6K9K: Bayonet ISO 15170-A1-4.1, Deutsch DT04-3P						
Electromagnetic compatibility:	EMC 2014/30/EU, EN 61000-6-2:2005, EN 61000-6-3:2007						
Max. length of connection cable:	30 m						
Protection against reverse polarity, short-circuit and overvoltage:	Built-in						
Cable output thread size:	For DIN EN 175301: PG9 (outside diameter of cable 6 to 9 mm)						
Weight:	approx. 2.82 oz / 80 g (DIN EN 175301 approx. 3.88 oz / 110 g)						

¹⁾ Static pressure, dynamic pressure 30 to 50% lower. Values refer to the hydraulic or pneumatic part of the pressure transducer

²⁾ Within the compensated temperature range

³⁾ FKM sealings are only suitable for pressure ranges up to 0-16 bar.

T.1

hex 24
Performance

0601 / 0602

Electrical connectors and threads



DIN EN 17530-803-A

Pin	0601	0602
1	U _{V+}	U _{V+}
2	Gnd	I _{out}
3	U _{out}	nc
PE		

IP65

x ~ 60 mm without socket device
x ~ 77 mm with socket device

Connection code: 013

M12-DINEN61076-2-101A

Pin	0601	0602
1	U _{V+}	U _{V+}
2	U _{out}	nc
3	Gnd	I _{out}
4	nc	nc

IP67

x ~ 54 mm

Connection code: 002

ISO 15170 - A1 - 4.1

Pin	0601	0602
1	U _{V+}	U _{V+}
2	Gnd	I _{out}
3	U _{out}	nc
4	nc	nc

IP67, IP6K9K

x ~ 56 mm

Connection code: 015

AMP Superseal 1.5®

Pin	0601	0602
1	U _{out}	nc
2	Gnd	I _{out}
3	U _{V+}	U _{V+}

IP67

x ~ 61 mm

Connection code: 007

Deutsch DT04 - 3P

Pin	0601	0602
A	U _{V+}	U _{V+}
B	Gnd	I _{out}
C	U _{out}	nc

IP67, IP6K9K

x ~ 61 mm

Connection code: 014

Sealing ring

G1/4 DIN
EN ISO 1179-2
(DIN 3852-11)
form E

12

Thread code: 41

Sealing ring

14

NPT 1/4

Thread code: 09



0601 / 0602

Order matrix for pressure transducers

T.1

hex 24 Performance

	Type	Pressure range	Pressure connection	Seal material	Electrical connection
--	------	----------------	---------------------	---------------	-----------------------

0 – 10 V, 3-wire	0601
4 – 20 mA, 2-wire	0602

Max. overpressure ¹⁾	Burst pressure	Pressure range	
4 bar (58 psi)	8 bar (115 psi)	0 – 2 bar (approx. 29 psi)	200
10 bar (145 psi)	20 bar (290 psi)	0 – 4 bar (approx. 58 psi)	400
20 bar (290 psi)	35 bar (500 psi)	0 – 10 bar (approx. 145 psi)	101
40 bar (580 psi)	60 bar (870 psi)	0 – 16 bar (approx. 230 psi)	161
100 bar (1,450 psi)	140 bar (2,000 psi)	0 – 40 bar (approx. 580 psi)	401
150 bar (2,175 psi)	300 bar (4,350 psi)	0 – 100 bar (approx. 1,450 psi)	102
375 bar (5,439 psi)	500 bar (7,250 psi)	0 – 250 bar (approx. 3,625 psi)	252

Pressure connection

1/4 BSPP – (DIN 3852), form E, male thread	41
NPT 1/4	09

Seal material – Application areas

NBR (BunaN)	Hydraulic/machine oil, heating oil, air, nitrogen, water, etc	1
EPDM	Brake fluid, water, acetylene, hydrogen, oxygen etc.	2
FKM (Viton®) ²⁾	Hydraulic fluids (HFA, HFB, HFD), petrol/gasoline, etc.	3
TPE	Hydraulic/machine oil, water, air, nitrogen, acetylene, etc.	7

Electrical connection

DIN EN 175301-803-A (DIN 43650-A) ; socket device included	013
M 12x1 - DIN EN 61076-2-101-A	002
Bayonet ISO 15170-A1-4.1 (DIN 72585-A1-4.1)	015
AMP Superseal 1.5®	007
Deutsch DT04-3P	014

Order number:	06XX	XXX	XX	X	XXX
---------------	------	-----	----	---	-----

¹⁾ Static pressure, dynamic pressure 30 to 50% lower. Values refer to the hydraulic or pneumatic part of the pressure transducer.

²⁾ FKM sealings are only suitable for pressure ranges up to 0-16 bar.

T.2

hex 22

stainless steel

1.4305 / AISI 303

Robust pressure transmitters

Stainless steel housing (1.4305 / AISI 303, hex 22)



- Pressure transmitters especially for low pressures, including vacuum applications
- High overpressure protection (up to 3 x)
- Long life time even under high pressure change rates
- Housing and wetted parts are made of stainless steel providing excellent media compatibility
- Suitable for hydrogen and oxygen applications¹⁾
- The highly-sensitive piezo-resistive sensor in the measuring cell filled with oil guarantees high level of accuracy, repeatability and long-term stability
- The availability of different sealing materials enables deployment in a broad temperature range with a diverse array of media

¹⁾ For oxygen applications, the EPDM diaphragm can only be used up to 10 bar and a media temperature of max. +60°C.

Technical details

Piezo-Resistive Sensor
in Oil-Filled Housing
Stainless Steel 303

Type:	0645	0650	0660
Output signal:	0.5 – 4.5 V ratiometric	0 – 10 V (3-wire)	4 – 20 mA (2-wire)
Supply voltage U_B :	5 VDC \pm 10 % max. 6.5 VDC	12 - 32 VDC	10 - 32 VDC
Permissible load apparent ohmic resistance:	\geq 4,7 k Ω	\geq 4,7 k Ω	$\leq (U - 10 V) / 20 \text{ mA}$ v+
Idle power consumption:	approx. 5 mA		< 4 mA

Type:	0645 / 0650 / 0660								
Standard pressure ranges p_{nom} :	-1 -0 bar (vacuum) (-14.5 - 0 psi)	-1-1 bar (compound)	0-1 bar (0 - 14 psi)	0 - 4 bar (0 - 58 psi)	0 - 6 bar (0 - 87 psi)	0 - 10 bar (0 - 145 psi)	0 - 16 bar (0 - 232 psi)	0 - 40 bar (0 - 580 psi)	0 - 100 bar (0 - 1,450 psi)
Overpressure protection $p_u^{1)}$:	3 bar (43 psi)	3 bar (43 psi)	3 bar (43 psi)	8 bar (116 psi)	12 bar (174 psi)	20 bar (290 psi)	32 bar (464 psi)	80 bar (1,160 psi)	200 bar (2,900 psi)
Burst pressure ¹⁾ :	10 bar (145 psi)	10 bar (145 psi)	10 bar (145 psi)	20 bar (290 psi)	30 bar (435 psi)	35 bar (500 psi)	40 bar (580 psi)	100 bar (1,450 psi)	250 bar (3,625 psi)
Mechanical life expectancy:	10,000,000 pulsations at rise rates to 14,500 psi/s (1,000 bar/s) at p_{nom}								
Permitted pressure change rate:	\leq 14,500 psi/ms (\leq 1,000 bar/ms)								
Accuracy:	\pm 0.5 % full scale (FS) at room temperature, \pm 0.25 % BFSL								
Long term stability:	< \pm 0.2 % of full scale (FS) per year								
Repeatability ²⁾ :	\pm 0.1 % FS								
Temperature error ²⁾ :	\pm 0.02 % of full scale (FS) / °C; -1 ... 1 bar \pm 0.03 % of full scale (FS) / °C								
Compensated temperature range:	-10°C ... +70°C (+14°F ... +158°F)								
Temperature range ambient:	-40°C ... +100°C (-40°F ... +212°F)								
Temperature range media:	with NBR (BunaN) seal: (-22°F ... +212°F) -30°C ... +100°C								
	with EPDM seal: (-22°F ... +257°F) -30°C ... +125°C								
	with FKM (Viton®) seal: (-4°F ... +257°F) -20°C ... +125°C								
Wetted parts material	Housing:	Stainless steel AISI 303 / 1.4305							
	Measuring cell:	Stainless steel AISI 316L / 1.4404							
	Seal material:	NBR (BunaN), EPDM or FKM (Viton®)							
Standard sensor oil:	Fluorine oil (not suitable for food applications)								
Insulation resistance:	> 100 M Ω (35 VDC)								
Response time 10 – 90%:	< 2 ms								
Vibration resistance:	20 g at 4 – 2000 Hz sine wave; DIN EN 60068-2-6								
Shock resistance:	half sine wave 500 m/s ² 11ms; DIN EN 60068-2-27								
Protection class	Refer to the electrical connections								
Electromagnetic compatibility:	EMC 2014/30/EU, EN 61000-6-2:2005, EN 61000-6-3:2007								
Max. length of connection cable:	30 m								
Protection against reverse polarity, short-circuit and overvoltage:	Built-in								
Weight:	approx. 2.82 oz / 80 g (DIN EN 175301 approx. 3.88 oz / 110 g, cable output approx. 4.76 oz / 135 g)								

¹⁾ Static pressure. Dynamic value is 30 to 50% lower. Values refer to the hydraulic/pneumatic part of the pressure transducer.

²⁾ Within the compensated temperature range.

T.2

hex 22
 stainless steel
 1.4305 / AISI 303



0645 / 0650 / 0660

Electrical connectors and threads

DIN EN 175301-803-A

Pin	0645 / 0650	0660
1	U_{V+}	U_{V+}
2	Gnd	I_{out}
3	U_{out}	nc
PE		

IP65

$x \sim 60$ mm without socket device
 $x \sim 76$ mm with socket device

$d \sim \varnothing 30$ mm

Connection code: 013

M12 – DIN EN 61076-2-101 A

Pin	0645 / 0650	0660
1	U_{V+}	U_{V+}
2	U_{out}	nc
3	Gnd	I_{out}
4	nc	nc

IP67

$x \sim 54$ mm

$d \sim \varnothing 22$ mm

Connection code: 002

ISO 15170-A1-4.1

Pin	0645 / 0650	0660
1	U_{V+}	U_{V+}
2	Gnd	nc
3	U_{out}	I_{out}
4	nc	nc

IP67

$x \sim 65$ mm

$d \sim \varnothing 27$ mm

Connection code: 004

Cable connection

1: red
 2: white
 3: black

Pin	0645 / 0650	0660
1	U_{V+}	U_{V+}
2	U_{out}	nc
3	Gnd	I_{out}

IP67

$x \sim 44$ mm (+ 20 mm bend relief)
 Cable length ~ 2 m

$d \sim \varnothing 22$ mm

Connection code: 011

Sealing ring
 G1/4 DIN
 EN ISO 1179-2
 (DIN 3852-11)
 form E

Thread code: 41



0645 / 0650 / 0660

Article matrix for pressure transmitters

T.2

hex 22
stainless steel

1.4305 / AISI 303

	Type	Pressure range	Pressure connection	Seal material	Electrical connection
--	------	----------------	---------------------	---------------	-----------------------

0.5 - 4.5 V ratiometric	0645
0 - 10 V, 3-wire	0650
4 - 20 mA, 2-wire	0660

Pressure range	Max. Overpressure ¹⁾	
-1 - 0 bar (Vacuum, approx. -29.6 inHg)	3 bar (14.5 psi)	000
-1- 1 bar (Compound pressure range)	3 bar (14.5 psi)	V01
0 - 1 bar (approx. 14.5 PSI)	3 bar (14.5 psi)	100
0 - 4 bar (approx. 58 PSI)	8 bar (116 psi)	400
0 - 6 bar (approx. 87 PSI)	12 bar (174 psi)	600
0 - 10 bar (approx. 145 PSI)	20 bar (290 psi)	101
0 - 16 bar (approx. 232 PSI)	32 bar (464 psi)	161
0 - 40 bar (approx. 580 PSI)	80 bar (1,160 psi)	401
0 - 100 bar (approx. 1,450 PSI)	200 bar (2,900 psi)	102

Pressure connection	
BSPP 1/4 - DIN EN ISO 1179-2 (DIN 3852-11), form E	41

Seal material	Application areas	Temperature range	
NBR	Hydraulic/machine oil, heating oil, air, nitrogen, water, etc.	-22 °F ... +212 °F (-30 °C ... +100 °C)	1
EPDM ²⁾	Brake fluid, water, acetylene, hydrogen, etc.	-22 °F ... +257 °F (-30 °C ... +125 °C)	2
FKM	Hydraulic fluids (HFA, HFB, HFD), petrol/gasoline, etc.	-4 °F ... +257 °F (-20 °C ... +125 °C)	3

Electrical connection	
DIN EN 175301-803-A (DIN 43650-A); socket device included	013
M12x1 - DIN EN 61076-2-101-A	002
Bayonet ISO 15170-A1-4.1 (DIN 72585-A1-4.1)	004
Cable connection (length of cable 2 m standard)	011

Article number:	06XX	XXX	41	X	XXX
-----------------	------	-----	----	---	-----

¹⁾ Static pressure, dynamic pressure 30 to 50% lower. Values refer to the hydraulic or pneumatic part of the pressure transmitter.

²⁾ For oxygen applications, the EPDM diaphragm can only be used up to 10 bar and a media temperature of max. +60°C.

T.3

hex 22

stainless steel

1.4404 / AISI 316L

Robust pressure transmitters

Stainless steel housing 1.4404 / AISI 316L, hex 22



- Pressure transmitters especially for low pressures, including vacuum applications
- Long life time even under high pressure change rates
- Housing and wetted parts are made of stainless steel 1.4404 providing excellent media compatibility when used in seawater, chemical and process technology applications
- The highly-sensitive piezo-resistive sensor in the measuring cell filled with oil guarantees high level of accuracy, repeatability and long-term stability
- The availability of different sealing materials enables deployment in a broad temperature range and with a diverse array of media

Robust pressure transmitters

Technical details

	0675	0680	0690
Output signal:	0.5 - 4.5 V ratiometric	0 - 10 V (3-wire)	4 - 20 mA (2-wire)
Supply voltage U_{V+} :	5 VDC $\pm 10\%$ max. 6,5 VDC	12 - 32 VDC	10 - 32 VDC
Permissible load / apparent ohmic resistance:	$\geq 4.7\text{ k}\Omega$	$\geq 4.7\text{ k}\Omega$	$\leq (U_{V+} - 10\text{ V}) / 20\text{ mA}$
Idle power consumption:	approx. 5 mA		< 4 mA

	0675 / 0680 / 0690									
Standard pressure ranges p_{nom} :	-1 - 0 bar (vacuum) (-14.5-0 psi)	-1 - 1 bar (compound) (-14.5 to 14.5)	0 - 1 bar (0-14.5 psi)	0 - 4 bar (0-58 psi)	0 - 6 bar (0-87 psi)	0 - 10 bar (0-145 psi)	0 - 16 bar (0-232 psi)	0 - 40 bar (0-580 psi)	0 - 100 bar (0-1,450 psi)	
Overpressure protection p_u ¹⁾ :	3 bar (43 psi)	3 bar (43 psi)	3 bar (43 psi)	8 bar (116 psi)	12 bar (174 psi)	20 bar (290 psi)	32 bar (464 psi)	80 bar (1,160 psi)	200 bar (2,900 psi)	
Burst pressure ¹⁾ :	10 bar (145 psi)	10 bar (145 psi)	10 bar (145 psi)	20 bar (290 psi)	30 bar (435 psi)	35 bar (500 psi)	40 bar (580 psi)	100 bar (1,450 psi)	250 bar (3,650 psi)	
Mechanical life expectancy:	10,000,000 pulsations at rise rates to 14,500 psi /s (1,000 bar/s) at p_{nom}									
Permitted pressure change rate:	$\leq 14,500\text{ psi/s}$ ($\leq 1,000\text{ bar/s}$)									
Accuracy:	$\pm 0.5\%$ full scale (FS) at room temperature, $\pm 0.25\%$ BFSL									
Long term stability:	< $\pm 0.2\%$ of full scale (FS) per year									
Repeatability ²⁾ :	$\pm 0.1\%$ FS									
Temperature error ²⁾ :	$\pm 0.02\%$ of full scale (FS) / °C; -1 ... 1 bar $\pm 0.03\%$ of full scale (FS) / °C									
Compensated temperature range:	14 °F ... 158 °F (-10 °C ... +70 °C)									
Temperature range ambient:	-40 °F ... 212 °F (-40 °C ... +100 °C)									
Temperature range media:	with NBR seal: -22 °F ... +212 °F (-30 °C ... +100 °C)									
	with EPDM seal: -22 °F ... +257 °F (-30 °C ... +125 °C)									
	with FKM seal: -4 °F ... +257 °F (-20 °C ... +125 °C)									
Wetted parts material	Housing:	Stainless steel 1.4404 (AISI 316L)								
	Measuring cell:	Stainless steel 1.4404 (AISI 316L)								
	Seal material:	NBR, EPDM or FKM								
Standard sensor oil:	Fluorine oil ³⁾									
Insulation resistance::	> 100 M Ω (35 VDC)									
Response time 10 - 90 %:	$\leq 2\text{ ms}$									
Vibration resistance:	20 g at 4 - 2000 Hz sine wave; DIN EN 60068-2-6									
Shock resistance:	half sine wave 500 m/s ² ; 11ms; DIN EN 60068-2-27									
Protection class	Refer to the electrical connections									
Electromagnetic compatibility:	EMC 2014/30/EU, EN 61000-6-2:2005, EN 61000-6-3:2007									
Max. length of connection cable:	30 m									
Protection against reverse polarity, short-circuit and overvoltage:	Built-in									
Weight:	approx. 80 g (DIN EN 175301 approx. 110 g, cable output approx. 135 g)									

¹⁾ Static pressure. Dynamic value is 30 to 50% lower. Values refer to the hydraulic/pneumatic part of the pressure transmitter.

²⁾ Within the compensated temperature range.

³⁾ not suitable for food applications

T.3

hex 22
 stainless steel
 1.4404 / AISI 316L

0675 / 0680 / 0690

Electrical connectors and threads



DIN EN 175301 - 803 - A

Pin	0675 / 0680	0690
1	U_{V+}	U_{V+}
2	Gnd	I_{out}
3	U_{out}	nc
PE		

IP65

$x \sim 60$ mm without socket device
 $x \sim 76$ mm with socket device

$d \sim \varnothing 30$ mm

Connection code: 013

M12 – DIN EN 61076 - 2 -101 A

Pin	0675 / 0680	0690
1	U_{V+}	U_{V+}
2	U_{out}	nc
3	Gnd	I_{out}
4	nc	nc

IP67

$x \sim 54$ mm

$d \sim \varnothing 22$ mm

Connection code: 002

ISO 15170-A1-4.1

Pin	0675 / 0680	0690
1	U_{V+}	U_{V+}
2	Gnd	nc
3	U_{out}	I_{out}
4	nc	nc

IP67

$x \sim 65$ mm

$d \sim \varnothing 27$ mm

Connection code: 004

Cable connection

Pin	0675 / 0680	0690
1	U_{V+}	U_{V+}
2	U_{out}	nc
3	Gnd	I_{out}

IP67

$x \sim 44$ mm (+ 20 mm bend relief)
 Cable length ~ 2 m

$d \sim \varnothing 22$ mm

Connection code: 011

Sealing ring
 G1/4 DIN
 EN ISO 1179-2
 (DIN 3852-11)
 form E

Thread code: 41



0675 / 0680 / 0690

Article matrix for pressure transmitters

T.3

hex 22

stainless steel

1.4404 / AISI 316L

	Type	Pressure range	Pressure connection	Seal material	Electrical connection
	↓	↓	↓	↓	↓
0.5 - 4.5 V ratiometric	0675				
0 - 10 V, 3-wire	0680				
4 - 20 mA, 2-wire	0690				

Pressure range	Max. Overpressure ¹⁾	
-1 - 0 bar (Vacuum, approx. -29.6 inHg)	3 bar	000
-1 - 1 bar (Compound pressure range) ²⁾	3 bar	V01
0 - 1 bar (approx. 14.5 PSI)	3 bar	100
0 - 4 bar (approx. 58 PSI)	8 bar	400
0 - 6 bar (approx. 87 PSI)	12 bar	600
0 - 10 bar (approx. 145 PSI)	20 bar	101
0 - 16 bar (approx. 232 PSI)	32 bar	161
0 - 40 bar (approx. 580 PSI)	80 bar	401
0 - 100 bar (approx. 1,450 PSI)	200 bar	102

Pressure connection	
1/4 BSPP - DIN EN ISO 1179-2 (DIN 3852-11), form E	41

Seal material - Application areas			
NBR	Hydraulic/machine oil, air, nitrogen, water, etc.	-22 °F ... +212 °F -30 °C ... +100 °C	1
EPDM ³⁾	Brake fluid, water, acetylene, hydrogen, etc.	-22 °F ... +257 °F -30 °C ... +125 °C	2
FKM	Hydraulic fluids (HFA, HFB, HFD), petrol/gasoline, etc.	-4 °F ... +257 °F -20 °C ... +125 °C	3

Electrical connection	
DIN EN 175301-803-A (DIN 43650-A); socket device included	013
M12x1 - DIN EN 61076-2-101 A	002
Bayonet ISO 15170-A1-4.1 (DIN 72585-A1-4.1)	004
Cable connection (length of cable 2 m standard)	011

Article number	06XX	XXX	41	X	XXX

¹⁾ Static pressure, dynamic pressure 30 to 50% lower. Values refer to the hydraulic or pneumatic part of the pressure transmitter.

²⁾ Other compound pressure ranges on request.

³⁾ For oxygen applications, the EPDM diaphragm can only be used up to 10 bar and a media temperature of max. +60°C.

T.4

hex 22

High Performance

Pressure transmitters High-Performance series

Silicon-on-sapphire sensor technology (SoS), hex 22



- Outstanding overpressure protection (up to 4 x)
- Ideal choice for mobile hydraulic applications
- Long service life even under high pressure change rates
- Wetted parts made of stainless steel and titanium ensuring excellent media compatibility
- All welded design, no elastomeric seal
- Silicon-on-sapphire technology (SoS) for highest reliability, accuracy and reliable process monitoring
- Very low temperature error and very good long-term stability
- Customer specific solutions available on request

Pressure transmitters

High-Performance series

Technical details

	0705	0710	0720
Output signal:	0.5 - 4.5 V ratiometric	0 - 10 V (3-wire)	4 - 20 mA (2-wire)
Supply voltage U_{V+} :	5 VDC \pm 10 % max. 6.5 VDC	12 - 32 VDC	10 - 32 VDC
Permissible load / apparent ohmic resistance:	$\geq 4.7 \text{ k}\Omega$	$\geq 4,7 \text{ k}\Omega$	$\leq (U_{V+} - 10 \text{ V}) / 20 \text{ mA}$
Idle power consumption:	approx. 5 mA		< 4 mA

0705 / 0710 / 0720										
Pressure range in bar										
Standard pressure ranges p_{nom} :	0 - 10	0 - 16	0 - 25	0 - 40	0 - 60	0 - 100	0 - 160	0 - 250	0 - 400	0 - 600
Overpressure protection p_U : ¹⁾	40	64	100	160	240	400	640	1,000	1,600	1,650
Burst pressure ²⁾ :	80	128	200	320	480	800	1,280	2,000	2,000	2,000
Pressure range in PSI										
Standard pressure ranges p_{nom} :	0 - 150	0 - 200	0 - 300	0 - 600	0-1,000	0-1,500	0-2,500	0-3,000	0-6,000	0-8,700
Overpressure protection p_U : ¹⁾	300	580	580	1,450	2,900	2,900	5,800	5,800	10,870	12,180
Burst pressure ²⁾ :	450	870	870	2,175	4,350	4,350	8,700	8,700	14,500	15,230
Technical parameters										
Mechanical life expectancy:	10,000,000 pulsations at rise rates to 5,000 bar/s at p_{nom}									
Permitted pressure change rate:	$\leq 72,518 \text{ psi/s}$ ($\leq 5,000 \text{ bar/s}$)									
Accuracy:	$\pm 0.5 \%$ full scale (FS) at room temperature, $\pm 0.25 \%$ BFSL									
Long term stability:	$\pm 0.1 \%$ FS p. a.									
Repeatability : ²⁾	$\pm 0.1 \%$ FS									
Temperature error : ²⁾	$\pm 0.01 \%$ FS / °C									
Compensated temperature range:	-40 °F ... 176 °F (-40 °C ... +80 °C)									
Temperature range ambient:	-40 °F ... 212 °F (-40 °C ... +100 °C)									
Temperature range media:	-40 °F ... +257 °F (-40 °C ... +125 °C)									
Wetted parts material:	stainless steel 1.4305 / SAE Grade 303, titanium									
Insulation resistance:	> 100 M Ω (35 VDC)									
Response time 10 - 90 %:	$\leq 2 \text{ ms}$									
Vibration resistance:	20 g at 4 - 2000 Hz sine wave; DIN EN 60068-2-6									
Shock resistance:	half sine wave 500 m/s ² ; 11ms; DIN EN 60068-2-27									
Protection class:	IP67 for M12x1, DIN 72585 (bayonet) and cable connector IP65 for DIN EN 175301-803									
Electromagnetic compatibility:	EMC 2014/30/EU, EN 61000-6-2, EN 61000-6-3									
Max. length of connection cable:	30 m									
Protection against reverse polarity, short-circuit and overvoltage:	Built-in									
Weight:	approx. 80 g (DIN 175301 approx. 110 g, cable outlet approx. 135 g)									

¹⁾ Static value, dynamic value is 30 to 50% lower. Values refer to the hydraulic/pneumatic part of the pressure transmitter / transducer.
²⁾ Within the compensated temperature range.



T.4

hex 22

High Performance

0705 / 0710 / 0720

Electrical connectors and threads



DIN EN 175301- 803 - A

Pin	0705 / 0710	0720
1	U _{out}	nc
2	Gnd	I _{out}
3	U _{V+}	U _{V+}
PE		

IP65

x ~ 60 / 76 mm*

d ~ Ø 30 mm

Connection code: 001

M12 DIN EN 61076 - 2-101 A

Pin	0705 / 0710	0720
1	U _{V+}	U _{V+}
2	U _{out}	nc
3	Gnd	I _{out}
4	nc	nc

IP67

x ~ 54 mm

d ~ Ø 22 mm

Connection code: 002

ISO 15170 - A1 - 4.1

Pin	0705 / 0710	0720
1	U _{V+}	U _{V+}
2	Gnd	nc
3	U _{out}	I _{out}
4	nc	nc

IP67, IP6K9K

x ~ 65 mm

d ~ Ø 27 mm

Connection code: 004

AMP Superseal 1.5 °

Pin	0705 / 0710	0720
1	U _{out}	nc
2	Gnd	I _{out}
3	U _{V+}	U _{V+}

IP67

x ~ 73 mm

d ~ Ø 26 mm

Connection code: 007

* x ~ 60 mm without coupler socket, x ~ 76 mm with coupler socket

Deutsch DT04 - 4P

Pin	0705 / 0710	0720
1	Gnd	I _{out}
2	U _{V+}	U _{V+}
3	nc	nc
4	U _{out}	nc

IP67, IP6K9K

x ~ 74 mm

d ~ Ø 23 mm

Connection code: 008

Deutsch DT04 - 3P

Pin	0705 / 0710	0720
A	U _{V+}	U _{V+}
B	Gnd	nc
C	U _{out}	I _{out}

IP67, IP6K9K

x ~ 74 mm

d ~ Ø 23 mm

Connection code: 010

Cable connection

Pin	0705 / 0710	0720
1	U _{V+}	U _{V+}
2	U _{out}	nc
3	Gnd	I _{out}

IP67

x ~ 44 mm (+ 20 mm bend relief)
Cable length ~ 2m

d ~ Ø 22 mm

Connection code: 011

Thread code: 41

Thread code: 03

Thread code: 04

Thread code: 09

Thread code: 30

Thread code: 20

Thread code: 21

Thread code: 42



0705 / 0710 / 0720

Article matrix for pressure transmitters

T.4

hex 22

High Performance

	Type	Pressure range bar / PSI	Pressure connection	Pressure unit	Electrical connection
0.5 - 4.5 V ratiometric	0705				
0 - 10 V, 3-wire	0710				
4 - 20 mA, 2-wire	0720				

Pressure range in bar ¹⁾

0 - 10 bar	101
0 - 16 bar	161
0 - 25 bar	251
0 - 40 bar	401
0 - 60 bar	601
0 - 100 bar	102
0 - 160 bar	162
0 - 250 bar	252
0 - 400 bar	402
0 - 600 bar	602

Pressure range in PSI ¹⁾

0 - 150 PSI	152
0 - 200 PSI	202
0 - 300 PSI	302
0 - 600 PSI	602
0 - 1,000 PSI	103
0 - 1,500 PSI	153
0 - 2,500 PSI	253
0 - 3,000 PSI	303
0 - 6,000 PSI	603
0 - 8,700 PSI	873

B

P

Pressure connection

1/4 BSPP – DIN EN ISO 1179-2 (DIN 3852-11), form E	41
1/4 BSPP – DIN 3852-A	03
NPT 1/8 (max. to 250 bar)	04
NPT 1/4	09
M 10 x 1 cyl. DIN 3852-A (max. to 250 bar)	30
7/16 – 20 UNF (max. to 250 bar)	20
9/16 – 18 UNF	21
M 14 x 1,5 – DIN EN ISO 9974-2 (DIN 3852-11), form E	42

Pressure unit ²⁾

bar	B
PSI	P

Electrical connection

DIN EN 175301-803-A (DIN 43 650-A) ; socket device included	001
M 12 – DIN EN 61076-2-101 A	002
Bayonet ISO 15170-A1-4.1 (DIN 72585-A1-4.1)	004
AMP Superseal 1.5®	007
Deutsch DT04-4P	008
Deutsch DT04-3P	010
Cable connection (length of cable 2 m standard)	011

Article number	07XX	XXX	/	XXX	XX	X	XXX
----------------	------	-----	---	-----	----	---	-----

¹⁾The respective overpressure and burst pressure values of the individual pressure ranges (in bar and PSI) can be found in the „Technical data“ on page 157.

²⁾The pressure unit (bar or PSI) must correspond to the selected pressure range (in bar or PSI).

T.5

hex 22

stainless steel

CAN bus technology

Digital Pressure Transmitter with CANopen / CAN J1939 Interface

Hex 22

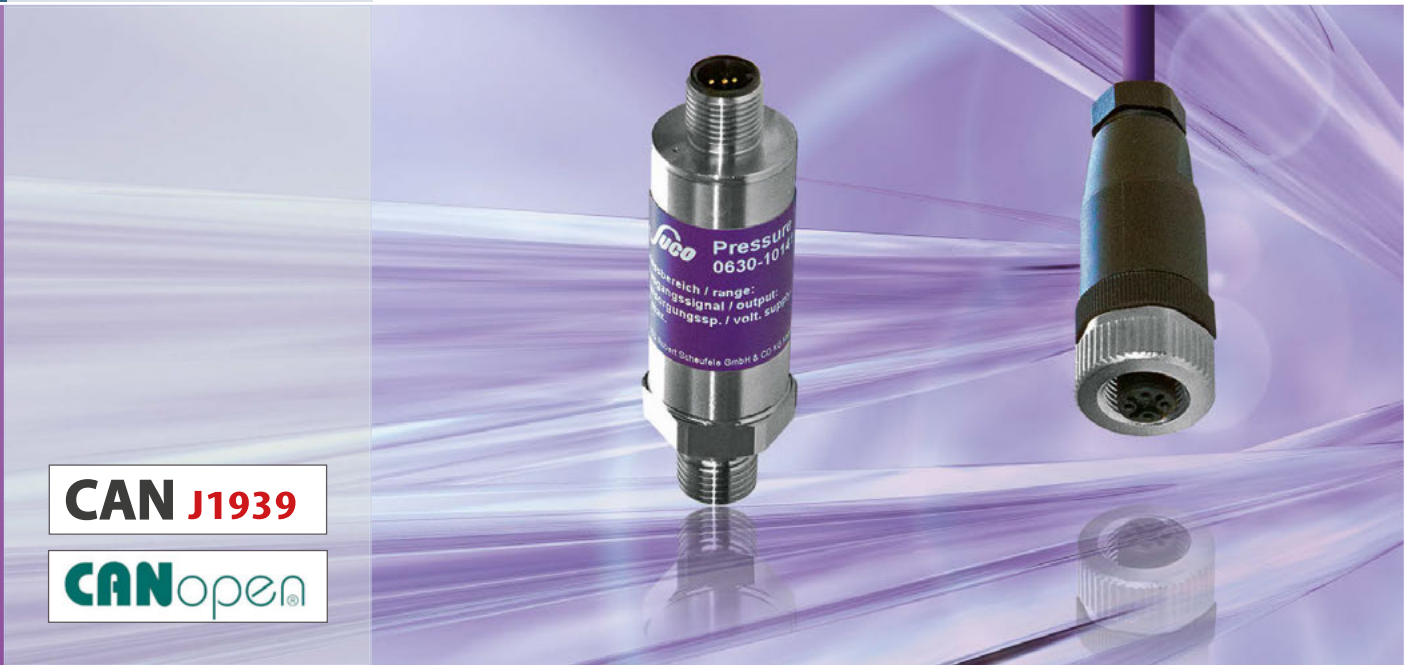

- Type 0630: CANopen protocol according to CiA DS-301, Device profile according to CiA DS-404
- Type 0631: CAN J1939 protocol according to SAE J1939
- Robust stainless steel construction with high reliability, even in very rough environments
- Completely welded measuring cell made of stainless steel 1.4542 / AISI 630 ensures excellent media compatibility ¹⁾
- Measuring ranges from 0 - 1 bar to 0 - 600 bar

¹⁾ excludes pressure range from 0 - 1 bar consisting of completely welded oil-filled measuring cell made of stainless steel 1.4404 / AISI 316L.

Digital Pressure Transmitter with CANopen / CAN J1939 Interface

Technical details

	0630	0631
Output protocol:	CANopen DIN EN 50325-4 ^{1) 2)}	SAE J1939 ¹⁾
Supply voltage U_B :	10 V - 32 VDC	10 V - 32 VDC
Idle power consumption:	< 30 mA	< 30 mA
CAN Interface:	acc. to DIN ISO 11898-2 CAN 2.0 A	acc. to DIN ISO 11898-2 CAN 2.0 B

0630 / 0631														
Pressure ranges in bar														
Standard pressure ranges p_{nom} :	0 - 1	0 - 2.5	0 - 4	0 - 6	0 - 10	0 - 16	0 - 25	0 - 40	0 - 60	0 - 100	0 - 160	0 - 250	0 - 400	0 - 600
Overpressure protection p_U ³⁾ :	2	6	10	20	20	40	100	100	200	200	400	750	750	840
Burst pressure ³⁾ :	5	9	15	30	30	60	150	150	300	300	600	1,000	1,000	1,050
Pressure ranges in PSI														
Standard pressure ranges p_{nom} :	0-15	0-150	0-200	0-300	0-600	0-1,000	0-1,500	0-2,500	0-3,000	0-6,000	0-8,700			
Overpressure protection p_U ³⁾ :	30	300	580	580	1,450	2,900	2,900	5,800	5,800	10,870	12,180			
Burst pressure ³⁾ :	75	450	870	870	2,175	4,350	4,350	8,700	8,700	14,500	15,230			
Technical parameters														
Mechanical life expectancy:	10,000,000 pulsations at rise rates to 1,000 bar/s at p_{nom}													
Permitted pressure change rate:	≤ 1,000 bar/s													
Accuracy:	±0.5 % of full scale (FS) at room temperature ⁴⁾ , ±0.25 % BFSL													
Long-term stability:	< ±0.1 % of full scale (FS) per year													
Repeatability ⁵⁾ :	±0.1 % of full scale (FS)													
Temperature error ⁵⁾ :	1.0 % of full scale (FS)													
Compensated temperature range:	-20 °C ... +85 °C													
Temperature range ambient:	-40 °C ... +105 °C													
Temperature range media:	-40 °C ... +125 °C													
Wetted parts material	Housing:	Stainless steel 1.4301 / AISI 304 (0 - 1 bar to 0 - 400 bar) Stainless steel 1.4542 / AISI 630 (0 - 600 bar)												
	Measuring cell:	Stainless steel 1.4404 / AISI 316L (0 - 1 bar) Stainless steel 1.4542 / AISI 630 (0 - 2.5 bar to 0 - 600 bar)												
Insulation resistance:	100 MΩ (50 VDC)													
Response time 10 - 90 %:	< 1 ms													
Vibration resistance:	20 g acc. to IEC 68-2-6 and IEC 68-2-36													
Shock resistance:	1000 g acc. to IEC 68-2-32													
Protection class:	IP67 (IP00 without mating plug)													
Electromagnetic compatibility:	EN 61326-2-3													
Weight	90 g													

¹⁾ Further information and the standard setting can be found in the Technical Documentation CANopen (1-6-30-628-058) and CAN J1939 (1-6-30-628-059) on our homepage at: <https://www.suco.de/en/downloads>.

²⁾ The EDS (Electronic Data Sheet) of our CANopen device can be downloaded from our homepage at: <https://www.suco.de/en/downloads>.

³⁾ Static pressure. Dynamic value is 30% to 50% lower. Values refer to the hydraulic/pneumatic part of the pressure transmitter.

⁴⁾ Including non-linearity, hysteresis, repeatability, zero error and full scale (FS) according to IEC 61298-2.

⁵⁾ Within the compensated temperature range. For pressure ranges < 3 bar: 1.5 % of fullscale (FS)



T.5

hex 22

stainless steel

CAN bus technology

0630 / 0631

Electrical connectors and threads



M12 DIN EN 61076 - 2-101 A CiA-DR303-1	
Pin	0630 / 0631
1	nc
2	U _{v+}
3	Gnd
4	CAN-High
5	CAN-Low
IP67	
x ~ 60 mm	
d ~ Ø 22 mm	
Connection code: 032	

G1/4 - DIN EN ISO 1179-2 (DIN 3852-E)
Thread code: 41

NPT 1/4
Thread code: 09



0630 / 0631

Article matrix for digital pressure transmitters

T.5

hex 22

stainless steel

CAN bus technology

	Type	Pressure range bar / PSI	Pressure connection	Pressure unit	Electrical connection
--	------	-----------------------------	------------------------	------------------	--------------------------

CANopen, CAN 2.0 A	0630
CAN J1939, CAN 2.0 B	0631

Pressure range in bar ¹⁾²⁾

0 - 1.0 bar	100
0 - 2.5 bar	250
0 - 4.0 bar	400
0 - 6.0 bar	600
0 - 10 bar	101
0 - 16 bar	161
0 - 25 bar	251
0 - 40 bar	401
0 - 60 bar	601
0 - 100 bar	102
0 - 160 bar	162
0 - 250 bar	252
0 - 400 bar	402
0 - 600 bar	602

Pressure range in PSI ¹⁾²⁾

0 - 15 PSI	151
0 - 150 PSI	152
0 - 200 PSI	202
0 - 300 PSI	302
0 - 600 PSI	602
0 - 1,000 PSI	103
0 - 1,500 PSI	153
0 - 2,500 PSI	253
0 - 3,000 PSI	303
0 - 6,000 PSI	603
0 - 8,700 PSI	873

B

P

Pressure connection

G 1/4 - DIN 3852, form E, male thread	41
NPT 1/4	09

Pressure unit

bar	B
PSI	P

Electrical connection

M12x1 - DIN EN 61076-2-101 A, CiA-DR303-1	032
---	------------

Article no.	063X	XXX	/	XXX	XX	X	032
-------------	-------------	------------	----------	------------	-----------	----------	------------

¹⁾ The proprietary PGN and SPN of the respective pressure range can be found in the Technical Documentation CAN J1939 (1-6-30-628-059) on our homepage at: <https://www.suco.de/en/downloads>.

²⁾ The respective overpressure and burst pressure values of the individual pressure ranges (in bar and PSI) can be found in the „Technical data“ on page 161.

³⁾ The pressure unit (bar or PSI) must correspond to the selected pressure range (in bar or PSI).

CAN J1939

CANopen

RoHS III
2002-95
compliant

CE

T

T.6

Accessories

Accessories

Mating plugs, thread adapters and transmitter display



- High-quality accessories
- Developed for our products
- Aligned to our products
- Direct from the manufacturer

Mating plugs

For requirements at short notice and for realising custom solutions

T.6
Accessories

<p>Deutsch DT06-3S (for DT04-3P) 3 x 0,5 mm² PUR cable (2 m), IP67</p>	<p>Suitable for connection code 010 Deutsch DT04-3P</p>	<p>Article number: 1-1-36-653-160</p>
--	---	--



<p>TE AMP Superseal 1.5°, 3-pin 3 x 0,5 mm² Radox cable (2 m), IP65</p>	<p>Suitable for connection code 007 AMP Superseal 1.5°</p>	<p>Article number: 1-1-32-653-158</p>
---	--	--

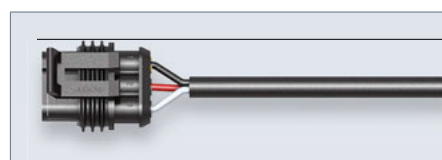

<p>M 12x1 DIN EN 61076-2-LF, 4-pin 4 x 0,34 mm² PUR cable (2 m), IP65</p>	<p>Suitable for connection code 002 M 12x1 DIN EN 61076-2-101 A</p>	<p>Article number: 1-1-00-653-162</p>
---	---	--

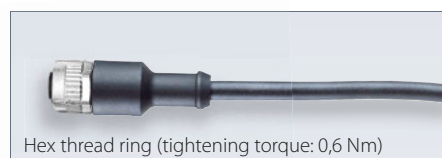

For the pin assignment of the wires please refer to chapter M.10 Accessories (page 91)

<p>Socket device M 12x1 DIN EN 61076-2-101 A straight, 4-pin</p> <p>Terminals for wire diameter 0.75 mm² (AWG 18)</p>	<p>Suitable for connection code 002</p> <p>M 12x1 DIN EN 61076-2-101-LF</p>	<p>Article number: 1-6-00-652-016</p>
--	--	--



<p>Socket device M 12x1 DIN EN 61076-2-101 A angled, 4-pin</p> <p>Terminals for wire diameter 0.75 mm² (AWG 18)</p>	<p>Suitable for connection code 002</p> <p>M 12x1 DIN EN 61076-2-101-LF</p>	<p>Article number: 1-6-00-652-017</p>
--	--	--

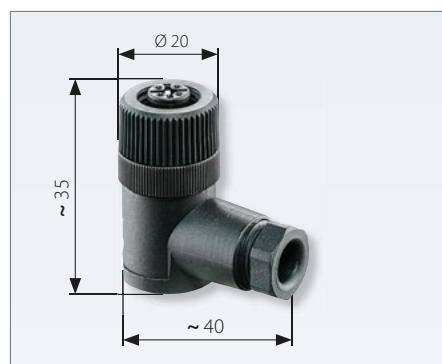

T.6



Accessories

Thread adapters

For requirements at short notice and for realising custom solutions

- The materials and shapes of thread adapters are aligned perfectly to our electronic pressure switches and transmitters
- Thread adapters are provided together with seals to ensure safe and easy installation of our electronic pressure switches and transmitters

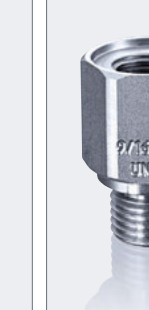

Stainless steel (1.4305 / AISI 303) thread adapters			
G 1/4 DIN EN ISO 1179-1 (DIN 3852-E) female thread			
			
M10 x 1 form A DIN 3852-1	M14 x 1.5 form E DIN 3852-E incl. FKM sealing ring	NPT 1/4-18	9/16-18UNF incl. O-ring FKM
hex 22 h = 30,5 mm	hex 22 h = 35 mm	hex 22 h = 35,5 mm	hex 22 h = 33 mm
Article number:	Article number:	Article number:	Article number:
1-1-00-420-020	1-1-00-420-028	1-1-00-420-021	1-1-00-420-027

SUCO Transmitter Display STD

- For pressure transmitters with 4 – 20 mA current output
- Suitable for pressure, temperature, level, force or flow indication
- Connection to DIN EN 175301-803-A (DIN 43650)
- Switching output option available (NO)

Technical details

Display:	LED, red, 4-digits, rotatable (4x90°)
Display range:	-999 ... 9999
Input signal:	4 ... 20 mA, 2-wire
Standard display:	4.00 ... 20.00 (pre-set at factory)
Accuracy:	0.2 % FS ±1 digit
Supply voltage:	17 ... 32 VDC
Max. loop current:	60 mA
Sampling rate:	300 ms – 25.5 s (configurable with filter)
Switching output (for STD1 and STD3):	PNP transistor output 90 mA (P-MOSFET) Embedded overcurrent protection
Hysteresis (for STD1 and STD3):	constant value 3 digits of pre-setting (e. g.: switching point = 20.0 psi, hysteresis = 0.3 psi)
Programming:	2 programming buttons are located underneath the removable front panel
Programming options:	
Zero point setting:	-999 ... 9999
Range:	0 ... 9999
Decimal points:	3 positions or disable
Average filter:	0.3 ... 25.5 s
Overrun:	On / off
Switching point (for STD1 and STD3):	-999 ... 9999
Switch function (for STD1 and STD3):	NO
Save settings:	In EEPROM
Error messages:	If the overrun function is selected, „HI“ is shown on the display when 20 mA is exceeded. „LO“ is displayed when the current drops below 4 mA. When the overrun function is disabled, „ErC6“ is displayed as soon as the value is no longer in range -999 ... 9999.
Temperature range:	-10°C ... +60°C
Housing material:	ABS / acrylic (display window)
Protection class:	IP65 when fitted
Electrical connection:	DIN EN 175301-803-A (DIN 43650)
Attachment screw:	Included in the delivery

Article number:

1-6-20-656-007	STD0 Display (for 0720)
1-6-20-656-008	STD1 Display with switching output (for 0720)
1-6-20-656-013	STD2 Display (for 0602 / 0660 / 0690)
1-6-20-656-014	STD3 Display with switching output (for 0602 / 0660 / 0690)

T.6

Accessories



Contact assignment:

PIN	Display (STD0)
1	nc
2	I _{out}
3	U _{V+}
PE	

PIN	Display with switching output (STD1):
1	PNP
2	I _{out}
3	U _{V+}
PE	

PIN	Display (STD2)
1	U _{V+}
2	I _{out}
3	nc
PE	

PIN	Display with switching output (STD3):
1	U _{V+}
2	I _{out}
3	PNP
PE	

Pressure Monitoring Systems and Transmission Technology



Our complete product range and sales network can be found online or in our catalogs.

Contact us or go online now.



Office Location: 863 Bowsprit Road, Chula Vista, CA 91914
Warehouse Location: 8268 Clairemont Mesa Blvd, Ste 302, San Diego, CA 92111

Line 1: +1 (619)-616-7350
Mobile: +1 (619)-600-1015

info@logicbus.com
 sales@logicbus.com
 support@logicbus.com
 orders@logicbus.com



Sucursal: Av. Miguel Hidalgo y Costilla #1443 Piso 6 Col. Americana (Torre Iclar) C.P. 44160, Guadalajara, Jalisco

Tel: +52 (33)-3854-5975

WhatsApp: +52 (55)-5431-6718
WhatsApp: +52 (33)-3443-8556

ventas@logicbus.com
 soporte@logicbus.com
 finanzas@logicbus.com