



# Pressure Switches and Transducers

The background of the page is a blue-tinted, high-angle photograph of industrial machinery. In the foreground, a metal component with a black plastic fitting is visible. In the mid-ground, a clear plastic component with a blue mesh filter is prominent. The background shows various pipes and mechanical parts, creating a sense of depth and industrial complexity.

**Mechanical Pressure Switches**

**Electronic Pressure Switches**

**Pressure Transmitters**

**Sensor Technology**

# Welcome to SUCO

What you'll see on the following pages:

## SUCO

SUCO – A leading specialist in pressure monitoring	Page 2
SUCO – A success story	Page 4
SUCO – Prepared for the future	Page 6
General technical explanations	Page 8

## MECHANICAL PRESSURE SWITCHES

	from Page 10
Overview of mechanical pressure switches	Page 12
Special technical explanations	Page 16
Selection Matrix – Choose your mechanical pressure switch	Page 18
Product descriptions and order numbers	from Page 22

## ELECTRONIC PRESSURE SWITCHES

	from Page 96
Overview of electronic pressure switches	Page 98
Special technical explanations	Page 100
Selection Matrix – Choose your electronic pressure switch	Page 105
Product descriptions and order numbers	from Page 106

## PRESSURE TRANSMITTERS

	from Page 134
Overview of pressure transmitters	Page 136
Special technical explanations	Page 138
Selection Matrix – Choose your pressure transmitter	Page 143
Product descriptions and order numbers	from Page 144

## esi SENSOR TECHNOLOGY

	from Page 168
ESI - A sensor specialist	Page 170
Brief overview of product lines	Page 171
Selection Matrix – Choose your pressure sensor	Page 174

SUCO worldwide – Our international sales network	Page 178
Order correctly – Explanation of SUCO order numbers	Page 180
Questionnaires for the selection of pressure switches and transmitters	Page 181

# SUCO Robert Scheuffele GmbH & Co. KG

A pressure monitoring specialist setting standards on the global stage

SUCO Robert Scheuffele GmbH & Co. KG was founded in 1938 and has established itself across the globe under the trade name SUCO. The two main product groups, pressure monitoring (mechanical pressure switches, vacuum switches, electronic pressure switches and pressure transmitters) and transmission technology (centrifugal clutches and brakes, electromagnetic clutches and brakes), as well as descent devices with centrifugal technology, are developed, designed and manufactured at the Bietigheim-Bissingen site, approximately 20 km north of Stuttgart in Germany.



Peter Stabel, Director



Marcell Kempf, Director

## Highest quality in all areas

The development and continual expansion of the company premises are indications of a thriving company.

Work on global presence has been rigorous, and today SUCO is actively represented by distribution companies in France (SUCO VSE France – a 50/50 joint venture with VSE Volumentchnik GmbH) and in the USA (SUCO Technologies Inc.), by associate company ESI Technology Ltd in Wrexham, North Wales, and by more than 50 mostly exclusive sales partners in over 60 countries.

Certified according to DIN EN ISO 9001:2015, SUCO has retained its consistently high quality standards for many years, something substantiated by numerous audits by reputable companies from a broad diversity of industry sectors.

This worldwide acknowledged product quality is guaranteed with CNC-controlled machining centres, automated assembly machines, sophisticated test systems and the latest in measuring equipment. Outstanding products, high level of customer service and excellent price/performance ratio guarantee SUCO good market positioning within the product sectors mentioned.

A sophisticated level of personnel qualification, a high identification of the employees with the company, process-oriented structures and efficient organisation are guarantees for continued company growth into the future.

Observance of ethical principles and comprehensive environmental awareness are standard at SUCO and guarantee business relationships on the highest level for our customers all over the world.

This catalogue does not only give a clear and structured overview of our capabilities all around our comprehensive range of pressure monitoring products but also offers detailed technical explanations supporting you in many challenges occurring in your specific applications.

**Please trust in a company with more than 80 years of experience.**

# SUCO – A success story

From a mechanical workshop to an industrial company operating on the global stage

**1938**

Robert Scheuffele starts up a mechanics workshop

**1945**

Start of the partnership between Robert Scheuffele and Georg Fuhrmann



\* 16.10.1909 † 20.02.1966 \* 15.01.1912 † 04.02.1982

**1946**

Start of production of centrifugal clutches and brakes

**1953**

Move into the new premises in Bietigheim-Bissingen, Keplerstrasse (still headquarter today)

**1956**

Registration of trade name SUCO with worldwide trademark protection

**1960**

Start of production of mechanical pressure switches for the automotive industry

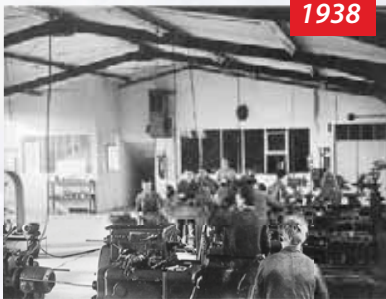

**1938**

A view into production



**1970**

Administration building, Bietigheim-Bissingen



**1989**

Aerial shot of premises, Bietigheim-Bissingen

**1997**

First DIN ISO 9001 company certification

**1998**

Start of market penetration in Asia with set-up of a company pool

Broadening of product expertise to electronic pressure monitoring

Start of the „fully automatic pressure switch adjusting“ development project with the Fraunhofer Institute

**1999**

Founding of subsidiary SUCO VSE France

**2001**

Certification to DIN ISO 9001:2000

**2002**

Penetration of the markets in South America and Eastern Europe

**2004**

Start of development of fully automatic assembly systems for pressure switch modules

**2005**

New company name: SUCO Robert Scheuffele GmbH & Co. KG

Development of the SUCO zero clutch

**1969**

Start of production of electromagnet clutches and brakes

Set-up of a pan-European sales network



**1979**

Further development of SUCO pressure switches especially for hydraulic and pneumatic applications

Strategic alignment to the industry

**1980**

Development of the hex 24 pressure switch series for broad industrial applications

**1984**

Development of the hex 27 pressure switch series for broad industrial applications

**1987**

Broadening of the product range to include custom pre-wired pressure switches

**1988**

Start of sales in the US

**1993**

Development of pressure dampers for ABS brake systems in the automotive industry



SUCO VSE France  
Le Mans, France



SUCO Technologies  
Boca Raton, USA



ESI Technology,  
Wrexham, UK



Aerial shot of premises,  
Bietigheim-Bissingen

**2006**

Development and production start of descenders with centrifugal technology

Enhancement of the laboratory test facility for simulating several million test cycles under different test conditions

Development of the world's smallest pressure switch with adjustable switching point to 400 bar (patented)

**2007**

Founding of subsidiary SUCO Technologies Inc., USA

**2009**

Acquisition of ESI Technology Ltd. (UK)

**2010**

Across-the-board use of enhanced automatic pressure switch adjusters

Development of a transmitter series based on SoS technology

**2011**

Development of the SUCO thermal brake

**2013**

75-year company anniversary celebrations

**2014**

Development of the PLUS series with additional intelligent functions

**2017**

Certification to DIN ISO 9001:2015

# Tradition and Innovation

The preservation of proven traditions and continuous efforts in innovation enable visions to become successful reality



Design and development of new products using the latest CAD tools.



Products are subjected to comprehensive testing and measurements to simulate realistic ambient conditions and loads.



Assembly and test of pressure switches on semi and fully automated installations.



Fully automated switching point adjustment with computer-aided documentation of readings.



Ultra-modern production facilities with integrated, fully automated component handling for high efficiency.



Encapsulating system for custom ready-wired pressure switches for strictest requirements of IP protection class.



State of the art measuring and test methods for assembly and alignment of our electronic products.



Product final inspection with ultra-modern computer-aided test systems.

# General technical explanations

## User information

Our pressure monitoring products may only be installed and started up by authorised specialists. The safety regulations of country-specific authorities must be observed, especially when working with mains voltages and oxygen, and in potentially explosive areas.

## Product information

The technical information in this catalogue is based upon fundamental testing during product development and empirical values. The information cannot be used for all application scenarios.

Testing of the suitability of our products for a specific application (such as the checking of material compatibilities) remains the responsibility of the user. It may be the case that suitability can only be verified by appropriate field testing.

## Mounting position

For mechanical and electronic pressure switches as well as transmitters there is no limitation due to the mounting position with regard to the accuracy of the pressure measurement.

However, other boundary conditions of the application may require a certain mounting position, e. g. horizontal installation to avoid waterlogging on the electrical connection or vertical installation to prevent debris from accumulating in the bore of the pressure connection.

## IP protection class

The IP protection class is a defined protection level code (sealing) of electrical equipment housings in line with IEC 60529 (formerly DIN 40050 – Part 2). Protection of a housing against the following is tested here:

- The penetration of solid extraneous particles, such as dust
- Access of hazardous parts
- Penetration of water

IP protection tests are performed as type tests.

The IP protection type code, made up of two digits, specifies the protection of a housing against the penetration of solid extraneous particles and water.

The numeric code therefore provides conclusions to be drawn on the level of personal safety as well as the functional protection / mid to longterm functional reliability of electrical equipment.

## Protection types IP00, IP65, IP67 and IP6K9K

### IP00:

No protection against penetration of solid particles or water, no protection against contact.

### IP6X:

Protection against penetration of dust (dust proof). Full contact protection.

### IPX5:

A jet of water from a nozzle, aimed at equipment (such as a pressure switch) from all directions, must not have any harmful effect.

### IPX7:

Protection from water, when equipment (such as a pressure switch) is immersed in water under defined pressure and time conditions. Water must not penetrate into the equipment in harmful quantities.

### IP6K9K:

Devices satisfying these requirements must be dust-proof and be able to withstand loads during the use of high-pressure cleaners and steam jets. The standard stipulates a water pressure from 80 to 100 bar at a temperature of 80 °C for testing.

### IP6KX:

Dust must not penetrate. Letter K: Specific to the electrical equipment of road vehicles.

### IPX9K:

Protection against penetration of water at high pressure / for steam jet cleaning. Water aimed at the housing from every direction at greatly increased pressure may not have any damaging effects.

We are able to offer IP67 / IP6K9K for many of our mechanical and electronic pressure switches (pre-wired or with integrated connector) and for our transmitters.

IP67 / IP6K9K is the recommended protection for mobile hydraulics and any equipment exposed to the outdoor environment.

## Cylindrical threads

Cylindrical threads are either sealed on the front by underlaying an appropriate sealing ring (such as a copper sealing ring) or by already having integrated O-rings or gaskets.

If the corresponding thread types do not provide specifications regarding the roughness of the counter sealing surface, we recommend the following values:

$$R_{a_{max}} 1.6 \mid R_{a_{max}} 6.3 \mid R_{mr} (-0.10) > 5 \% C_{ref} 5 \%$$

## Conical threads (cone-shaped threads)

Conical threads guarantee tolerance compensation of the two threaded parts. The sealing function is realised with thread flanks which deform permanently and enter into a metallic frictional fit. Conical threads are not screwed in down to the screw-in depth, but fixed with the tightening torque required for the leak tightness.

Remember not to exceed the permitted tightening torque of the pressure switch or transmitter presented in the following table (to prevent damaging the threaded pin beforehand, causing it to become untight during operation or to snap off when tightened).

## Tightening torques of steel threads

The specifications below are to be understood upper material thresholds for the housing of pressure switches or transmitters. Remember during installation that the type and material of the seal, the condition of mating surfaces (e.g. dry or oily) and the material of the counter-piece all have a bearing on the tightening torque.

Threads M10, G 1/8, R 1/8 and NPT 1/8 are limited to overpressure strengths of up to 600 bar.

Values 30% lower than in the following table must be used for brass housings.

Thread	Tightening torque
NPT 1/8; M 10 x 1 conical	max. 18 Nm
M 10 x 1 cyl.; G 1/8	max. 20 Nm
M 12 x 1.5; 7/16 – 20 UNF	max. 30 Nm
G 1/4; 9/16 – 18 UNF	max. 40 Nm
NPT 1/4; M 14 x 1.5	max. 40 Nm

### Gaseous applications

In particular using additional sealant to attain the required leak tightness may be necessary for gas applications.

### Plasma cleaning for oxygen applications

When pressure switches/transmitters are used with oxygen, the surfaces must be free of oil and grease residues to prevent spontaneous combustion. Special requirements must also be observed for oxygen applications with regard to the material selection of housings and seals as well as the permitted operating pressure (see also page 17). We would be pleased to advise you if necessary.

For these operating conditions, we offer plasma cleaning of the components in order to achieve the required elimination of oil and grease. The components are packed and sealed in plastic bags. The packaging is marked with safety instructions for use in oxygen applications.

### Plasma cleaning LABS-free (PWIS-free)

Our products are always manufactured without the use of substances that interfere with the wetting of the paint throughout the entire manufacturing process. For use in LABS-free applications, we offer plasma cleaning of the components. The components are packed and sealed in plastic bags. The packaging is marked with safety instructions for use in LABS applications.

### Vacuum

The values given in the technical details for the vacuum range are specified in millibars (mbar) below atmospheric pressure.

### Pressure change rate (~rise / ~fall)

The pressure change rate denotes the pressure over time for the rising/falling pressure. It is specified in bar/s.

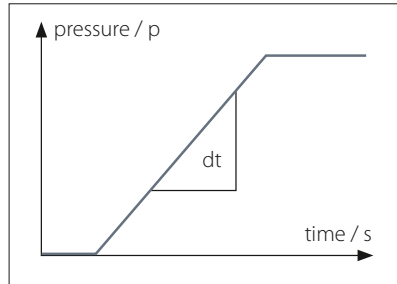

The maximum pressure change rate for mechanical pressure switches is 1,000 bar/s. For SUCO electronic pressure monitoring products the maximum pressure change rate can be up to 5,000 bar/s.

### Overpressure protection

The specified overpressure protection in the catalogue is based on a static pressure. The values refer to the hydraulic or pneumatic part of the switch.

It is best practice to use 30 - 50% lower values for dynamic pressure compared to static pressure. These empirical values are based on the knowledge that, in pressure systems, unexpected pressure peaks which are higher than the working pressure are generated as a result of activation of valves, sudden falling or rising load or simply the change of cross-sections in the pipes. With conventional measurement techniques (such as manometers), these pressure peaks are hardly measurable. Faster measurement systems must therefore be used for this data acquisition. Attempts are being made to take this into account by using empirical or corrective factors.

If the pressure conditions are known and the pressure change rates are 100 bar/s, our pressure switches and transmitters can be used up to the permitted overpressure protection as per data sheet / catalogue. Only 50 % of the specified overpressure protection is permitted when operating at the maximum permitted pressure change rate of  $\leq 1,000$  bar/s for mechanical pressure switches, and at  $\leq 5,000$  bar/s for transmitters.

### RoHS-Compliance

= Restriction of Hazardous Substances (Directives 2011/65/EU and 2020/863/EU)



### CE-Mark

= Communauté Européenne



European Parliament and Council directives must be observed when products are launched onto the market. If a directive exists for a product, it must be applied. Only products for which a directive exists may bear the CE mark.

**Only products which have been tested according to CE directive or corresponding standards may carry the CE mark.**

Mechanical pressure switches with a supply voltage above 50 VAC or 75 VDC are covered by the 2014/35/EU Low Voltage Directive. Variants for potentially explosive areas are covered in addition by the 2014/34/EU ATEX Product Directive.

Our electronic products satisfy EMC (Electromagnetic Compatibility) Directive 2014/30/EC. Mechanical pressure switches do not fall under the EMC Directive.

The Machinery Directive 2006/42/EC is not applicable, because our products are classed as components.

Our product designs are based upon „good engineering practise“ in line with Article 4, Paragraph 3 of the Pressure Equipment Directive (2014/68/EU), meaning neither a declaration of conformity may be issued nor a CE mark affixed.

The current product-specific EU declaration is available in the download area of our homepage:

[www.suco.de/en/downloads](http://www.suco.de/en/downloads)

**Subject to technical changes**

# M. Mechanical Pressure Switches



# M. Overview of mechanical pressure switches



M.1



M.2



M.3



M.4

**Technical explanations for mechanical pressure switches** from page 14

**Selection matrix**  
Help in selecting a suitable pressure switch from page 18

**M.1 Pressure and vacuum switches with integrated connector NC/NO, hex 24** from page 22

- Max. voltage up to 42 V
- Switching points: 0.1 – 150 bar or vacuum
- IP protection up to IP67 (IP6K9K)
- Available connectors:  
Deutsch DT04-2P, AMP Superseal 1.5°, Packard MetriPack 280°,  
Deutsch DT04-3P, AMP Junior Timer®, Bayonet DIN 72585 A1–2.1,  
M12x1 DIN EN 61076-2-D
- Housing materials: zinc-plated steel (CrVI-free), stainless steel or brass
- Types: 0110, 0111, 0112, 0113, 0114, 0115, 0116, 0117, 0118, 0119, 0120, 0121, 0122, 0123, 0124, 0125

**M.2 Pressure switches with integrated connector Changeover contacts, hex 27** from page 32

- Adjustable hysteresis
- Max. voltage up to 250 V
- Switching points: 0.3 – 200 bar
- IP protection up to IP67 (IP6K9K)
- Available connectors:  
TE AMP Superseal 1.5°, M12x1 DIN EN 61076-2-101A,  
Deutsch DT04-3P, DIN connector EN 175301
- Housing material: zinc-plated steel (CrVI-free), others on request
- Types: 0132, 0133, 0134, 0135, 0136, 0137, 0184, 0185, 0194, 0195

**M.3 Pressure switches NC/NO, hex 24** from page 40

- Max. voltage up to 42 V
- Switching points: 0.1 – 200 bar
- IP protection up to IP65 (IP00 terminals)
- Housing materials: zinc-plated steel (CrVI-free), stainless steel or brass
- Types: 0163, 0164, 0166, 0167, 0168, 0169

**M.4 Pressure switches Changeover contacts, hex 27** from page 52

- Adjustable hysteresis (apart from 0140 and 0141)
- Max. voltage up to 250 V
- Switching points: 0.3 – 400 bar
- IP protection up to IP65
- Housing materials: zinc-plated steel (CrVI-free) or stainless steel
- Types: 0140, 0141, 0170, 0171, 0180, 0181, 0183, 0186, 0187, 0190, 0191, 0196, 0197

**M.5 Ready-wired pressure switches, cabled and encapsulated individually to customer requirements** from page 62

- Numerous cable and connector variants
- IP protection up to IP67 (IP6K9K)
- Housing materials: zinc-plated steel (CrVI-free), stainless steel or brass
- Types: **0240, 0241**  
special feature: switching point adjustable on site even after assembly
- Technical characteristics for hex 24: see chapter M.3
- Technical characteristics for hex 27: see chapter M.4



**M.6 „PLUS“ – Pressure switches with integrated connector and intelligent supplementary functions, hex 24** from page 66

- Max. voltage dependent on custom function up to 42 V
- Numerous additional safety functions, such as:
- diagnostic function („fail-safe“) according to NAMUR (resistor)
- LED for visual check of switching status
- Overvoltage / overload protection (varistor)
- Types: **0410, 0411, 0412, 0413, 0414, 0415, 0416, 0417, 0418, 0419, 0424, 0425**



**M.7 Pressure switches Changeover contacts, 30 A/F** from page 74

- Square or block style
- Some with adjustable hysteresis
- Max. voltage up to 250 V
- Switching point adjustable 0.1 – 400 bar
- Housing material: aluminium
- Types: **0159, 0161, 0162, 0175**  
special feature: 0159 with knurled screw for simple adjustment of the switching point



**M.8 Pressure switches according to ATEX directive and IECEx scheme** from page 80

- Hex 27 for gas protection zones 1 + 2, dust protection zones 21 + 22 and mining M2
- 30 A/F for gas protection zones 1 + 2
- Housing material: zinc-plated steel (CrVI-free) or aluminium
- Types: **0165, 0340, 0341, 0342, 0343**



**M.9 Vacuum switches NC/NO or Changeover contacts, hex 24 or 30 A/F** from page 86

- Max. voltage up to 250 V
- Overpressure protection up to 35 bar
- Housing material: brass or aluminium
- Types: **0150, 0151**



**M.10 Accessoires for mechanical pressure switches** from page 90

- Protective caps
- Socket devices
- Thread adapters
- Plugs with ready-to-use cables  
(for pressure switches with integrated connector)

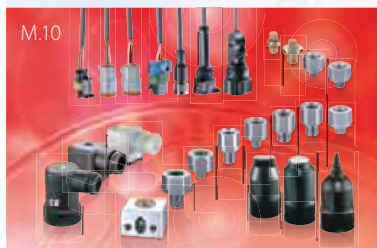

# Technical explanations for mechanical pressure switches

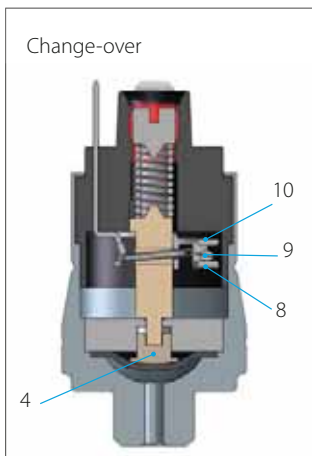
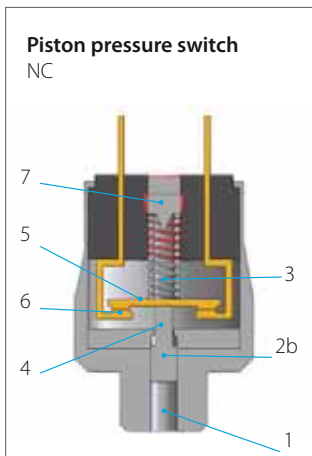
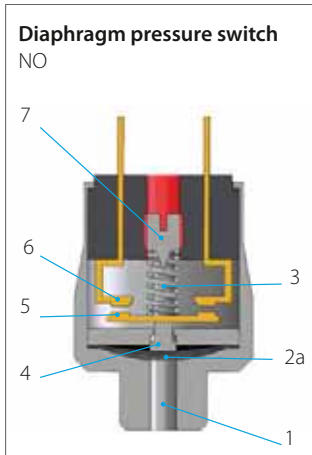

## What is a mechanical pressure switch?

Mechanical pressure switches from SUCO monitor the pressure of liquid or gaseous media, and close or open an electrical circuit on reaching a set threshold.

## Diaphragm pressure switches

SUCO diaphragm pressure switches are used in pressure ranges from 0.1 bar to 100 bar, meaning overpressure safety of 35, 100, 300 / 400 and 600 / 700 bar, depending on the used diaphragm type.

## Piston pressure switches

Pressure ranges from 10 bar to 400 bar can be monitored with SUCO piston pressure switches (dependent on size); overpressure safety of up to 600 / 700 bar can be attained.

## Sizes of pressure switches

Mechanical pressure switches from SUCO can be divided into sizes hex 24, hex 27 and 30 A/F. Each particular size has specific hydraulic, pneumatic and electric properties (specified on the relevant catalogue page in the technical details).

## How does a pressure switch work?

Function description for **normally open (NO)**: Pressure is applied to the diaphragm (2a) / pistons (2b) through the pressure connector (1).

If the generated pressure force is greater than the force of the pre-tensioned pressure spring (3), the plunger (4) moves towards the counter-contact (6), carrying along the contact disc (5), and closes the circuit.

The switch opens again when the pressure is reduced by the hysteresis value.

Function description for **normally closed (NC)**: Engaging happens in the reverse order.

The adjustment screw (7) enables the switching point to be changed within the adjustment range.

The micro switch of a **change-over contact system** (snap-action) offers both, a NC and a NO contact.

The swivel contact (9) is activated by the plunger (4). The circuit is closed by the NC (8) as long as no pressure is applied.

When the applied pressure exceeds the set switching point, the swivel contact changes over and closes the circuit via the NO (10).

## Utilisation category

The utilisation category specifies for example voltages and currents, and the type of load, our pressure switches are designed for (according to DIN EN 60947-5-1).

## AC voltage

**AC12**: Control of ohmic loads and semiconductor loads in input circuits of opto-couplers (such as PLC inputs).

**AC14**: Control of electromagnetic loads, 72 VA.

## DC voltage

**DC12**: Control of ohmic loads and semiconductor loads in input circuits of opto-couplers (such as PLC inputs).

**DC13**: Control of electromagnets.

## B10d value

According to DIN EN ISO 13849-1, the B10d value specifies the anticipated service life (with a 10% probability of failure). The B10d value is therefore directly dependent on the respective application of the pressure switch. For ohmic loads and currents < 1 A, we specify the B10d value as 1 million cycles of electrical life.

The specification of a MTTF time (mean time to failure) is not possible without knowing the specific conditions in the application. However, the MTTF time can be determined easily from the B10d value:

$$MTTF_d = \frac{B_{10d}}{0,1 n_{op}}$$

$n_{op}$ : number of cycles per year

$B_{10d}$ : number of cycles until 10 % of components have failed.

## Minimum current / minimum working voltage

The minimum working current and minimum working voltage depend greatly on operating and ambient conditions. Physically, the build-up of impurity layers on the contact rivets must be countered with mechanical friction and/or electrical erosion.

**Classification of electrical switch functions**

			Contact form DIN EN- 60947-5-1	Symbol IEC 60617
NO	NO, normally open	SPST single pole, single throw	X	
NC	NC, normally closed	SPST single pole, single throw	Y	
Change-over contacts	CO, change over (snap action)	SPDT single pole, double throw	C	

It has proven useful in many applications to deploy our pressure switches with silver contact rivets ensuring that they are fail safe to 10 mA and 10 V. Variants with gold contacts are available in our catalogue for even lower currents and voltages.

**Potential-free – galvanically isolated**

Mechanical pressure switches from SUCO are potential-free, i.e. no auxiliary energy is required. Also, there is no electrical contact between the individual, live parts and the housing.

**Adjustment range of switching point**

The pressure range, within which the switching point of a pressure switch can be set, is called adjustment range. The switching point corresponds to the pressure value at which the electric circuit is opened or closed by the pressure applied.

If no switching point is specified on order, the pressure switches are adjusted by approximately half the adjustment range at factory.

The setting ranges specified for the respective device series apply to increasing pressure. For switching points that are specified for falling pressure and are within the maximum value of the setting range minus the hysteresis, the next higher setting range must be selected (see also section „Hysteresis“).

**Switching point tolerances**

The switching point tolerances specified by us pertain to room temperature (RT) and condition as new.

The values can change as a result of temperature, ageing and deployment conditions.

It is not possible to specify generally applicable value for switching point tolerances over temperature as the medium has a significant influence on the sealing materials in the pressure switch.

Double the tolerance stated for RT and condition as new can be assumed as a typical magnitude for the tolerance over the entire temperature range.

Based on their design, piston switches may exhibit an increase in switching points due to storage (dry run, stick-slip effect). Following a short start phase, the switching points return to the value set at the factory.

Pressure change rates of > 1 bar/s may have an effect on the switching point for diaphragm pressure switches.

The switching point (for rising pressure) and hysteresis increase, whilst the switch-back point (for falling pressure) sinks.

Also, the effect of the maximum (system) pressure on the switchback point (for falling pressure ramp) must be factored in for tolerance-critical applications. The higher the (system) pressure, the lower the resulting switch-back value.

**Hysteresis**

**Rising / falling switching point**

The pressure difference between the rising (upper) and falling (lower) switching points (refer to the figure, e.g. NO) is known as hysteresis (switch-back difference).

Hysteresis has no constant value due to the structural layout of a mechanical pressure switch. In absolute values, the hysteresis is also the smallest with the smallest adjustment range. The hysteresis increases with increasing adjustment range.

**Hysteresis over rising switching point**

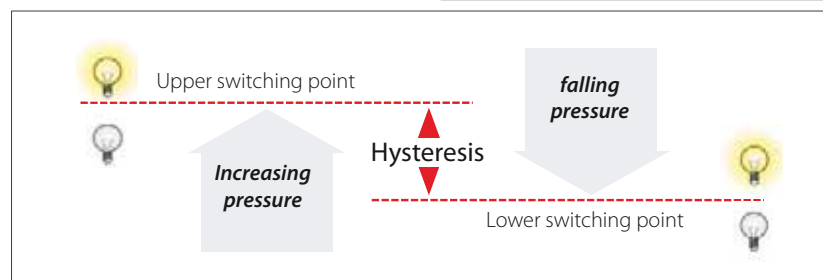
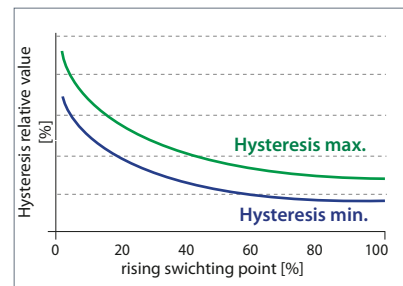
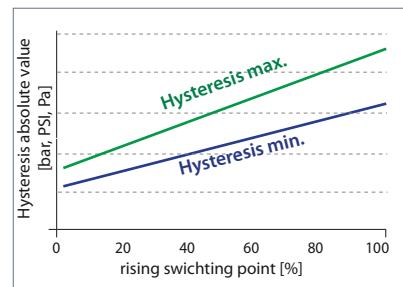

# Technical explanations for mechanical pressure switches

Hysteresis can be set at SUCO in range from approx. 10 % (at end of adjustment range) to 30 % or higher (at start of adjustment range), related to the respective switching point for hex 27 and 30 A/F pressure switches with adjustable hysteresis.

Due to their design, pressure switches with an overpressure resistance of 100 bar have smaller hystereses than the series with 300 bar or 400 bar overpressure resistance. Piston pressure switches have a slightly larger hysteresis than diaphragm pressure switches.

The specifications in the catalogue only represent typical average values. Please ask about the possible setting ranges you may require. Our electronic pressure switches are excellently suited to extremely low or high hysteresis. The lowest possible hysteresis is set if nothing is specified in the order.

## Switching frequency

The switching frequency provides information on the possible number of cycles in one minute. The value of 200/min specified by us is a guideline value. Higher switching frequencies can be attained depending on switch type and conditions of use.

## Sealing materials

The priority in sealing material selection is the chemical resistance. The temperature range only becomes a selection criterion when different sealing materials are suitable for the medium.

## NBR (Buna-N)

This is the standard material most commonly used. It is a special SUCO material mix with high level of cold flexibility so that the sealing properties of the pressure switch are also retained at low temperatures.

NBR is denoted by number „1“ in our order number.

## EPDM

This material is the solution of choice for applications with brake fluids. It is particularly suitable for applications with (process) water. Approval from the BAM (Federal Institute for Material Testing) is in place for oxygen applications.

The safety regulations from country-specific authorities must be observed for oxygen applications. EPDM may not come into contact with oil because this would entail swelling and softening of the material, and so failure of the pressure switch.

EPDM is denoted by number „2“ in our order number.

## EPDM-TW with drinking water approval

This EPDM material is intended for drinking water applications (up to max. 35 bar overpressure safety) according to Elastomer Guideline, WRAS (Water Regulation Advisory Scheme), ACS (Attestation de Conformité Sanitaire) and NSF 61 (National Sanitation Foundation) and for use in medical and pharmaceutical applications.

EPDM-TW may not come into contact with oil because this would entail swelling and softening of the material, and so failure of the pressure switch. Sealing is only available upon request, so please consult us before ordering.

EPDM-TW is denoted by number „5“ in our order number.

## FKM / FPM (Viton®)

This is a diaphragm material suitable for high temperature exposure and exhibits special chemical resistance. It has been tested in the hydraulic sector and has been proven to work successfully with critical oils.

FKM / FPM is denoted by number „3“ in our order number.

## FFKM

This diaphragm material is suitable for temperature exposure up to 120°C and can withstand very aggressive conditions such as chemical species including organic or inorganic acids, diluted alkalis, ketones, esters, alcohols, fuels and hot water.

FFKM is denoted by number „6“ in our order number.

## TPE (Thermoplastic elastomers)

This sealing material is available only for our electrical products of the Performance Series.

TPE offers similar media compatibility like NBR, e.g. suitable for mineral oil and hydraulic fluids.

Additionally the material can be used with diluted acids and bases and cold water, too.

TPE is denoted by number „7“ in our order number.

## ECO (epichlorhydrin)

ECO is only used in our vacuum switches. This material has similar properties to NBR in terms of chemical resistance, and can be used in gas applications as well as oil and fuel applications.

ECO is denoted by number „4“ in our order number.

## Silicone

Silicone is suitable for use within a wide temperature range. The SUCO silicone diaphragm is FDA-approved (Food & Drug Administration) for the food sector.

Silicone is a soft material reserved for sensitive applications in the low pressure range (below 10 bar) with maximum overpressure safety to 35 bar. Piston switches are therefore not offered with silicone seals. Silicone is also not suitable for oil applications.

Silicone is denoted by number „8“ in our order number.

## H-NBR

This is a special SUCO material mixture optimised for ester-based bio-oils. The multitude of bio-oils on the market means suitability of the material for the respective oil must be determined. This diaphragm material can also be used for a number of mineral and synthetic oils.

H-NBR is denoted by number „9“ in our order number.

## Medium compatibility

The specifications on medium compatibility in this catalogue cannot be generalised as they pertain to the sealing materials used in our pressure switches.

## Saturated and superheated steam applications

The sealing materials mentioned are not suitable for saturated or superheated steam applications.

### Conversion table for pressure units

Unit symbol	Unit name	Pa= N/m <sup>2</sup>	bar	Torr	lbf/in <sup>2</sup> , PSI
1 Pa = N/m <sup>2</sup>	Pascal	1	0.00001	0.0075	0.00014
1 bar	Bar	100 000	1	750.062	14.5
1 Torr = 1 mmHg	Millimetres, mercury column	133.322	0.00133	1	0.01934
1 lbf/in <sup>2</sup> = 1 PSI	Pound-force per square inch	6 894	0.06894	51.71	1

### Conversion table for temperature units

	K	°C	F
K	1	K - 273.15	9/5 K - 459.67
°C	°C + 273.15	1	9/5 °C + 32
F	5/9 (F + 459.67)	5/9 (F - 32)	1

#### Water applications

Standard piston switches are not suitable for water applications.

Pressure switches in stainless steel with EPDM seal have a special sealing system and can therefore also be used for water with corrosion protection, water mixtures or emulsions. The use of other fluid mixtures should be clarified with SUCO (e.g. swelling of EPDM sealing could happen by water – oil mixture).

Pressure switches with stainless steel housings with EPDM-TW diaphragm, SUCO type „5“ are designed for the use of drinking water.

#### Gas applications

Our pressure switches are suitable for liquid and gaseous media. Gaseous media place particular demands on leak-tightness however. The leakage rate is dependent on the respective gaseous medium, the working pressure and the permeability of the seal material used in the pressure switch.

Their lower leakage rates mean diaphragm pressure switches are better suited for gas pressures than piston pressure switches. The latter can also be used however if certain measures are taken (such as venting of the housing).

**For gaseous applications below 10 bar (145 PSI) in combination with pressure switches with high IP class, i.e. IP 67 and IP6K9K, in general we recommend to use ventilation. Please consult us; we are able to offer suitable solutions.**

#### Oxygen applications

Our mechanical pressure switches are suitable for use with oxygen. We recommend the use of our EPDM diaphragm. The resistance to internal burnout of the diaphragm has been tested by the BAM (Federal Institute for Material Testing).

Pressure switches with steel housings with zinc-nickel coating are, in conjunction with oxygen, only approved to a maximum working pressure of 10 bar.

Pressure switches with brass housings are, in conjunction with oxygen, only approved to a maximum working pressure of 35 bar.

Pressure switches with stainless steel housings are, in conjunction with oxygen, only approved to a maximum working pressure of 50 bar.

DGUV accident prevention regulations (such as DGUV 500, Section 2.32 and BGI 617) must be observed for first operation.

Please specify when ordering „oil and grease-free, for use with oxygen“.

#### Underpressure safety of pressure switches

Our pressure switches are underpressure safe down to 300 mbar (relative).

#### Overpressure safety of vacuum switches

Our vacuum switches are overpressure safe up to 20 or 35 bar depending on type.

#### cCSAus approval

Almost all of our mechanical pressure switches (sizes hex 24 and hex 27), and vacuum switch 0151, have cCSAus approval. The CSA mark together with „c“ and „us“ combines the control stamps for introduction onto the Canadian and American markets. The cCSAus certificate also includes the test of the relevant UL standard.

Checked by an official institution and verified with regular company visits by CSA inspectors, this approval guarantees the highest levels of quality and operational reliability for our products.

You can download the current cCSAus certificate on the download area of our homepage: <https://www.suco.de/en/downloads>

#### Product information

The technical information in this catalogue is based upon fundamental testing during product development, as well as upon empirical values. The information cannot be used for all application scenarios.

Testing of the suitability of our products for a specific application (e.g. also the checking of material compatibilities) rests under the responsibility of the user. It may be the case that suitability can only be guaranteed with appropriate field testing.

**Please consult us about gas, water and oxygen applications.**

**Subject to technical changes.**



		M.1 hex 24 with integrated connector														M.2 hex 27 with integrated connector						
		0110	0111	0112	0113	0114	0115	0116	0117	0118	0119	0120	0121	0122	0123	0124	0125	0132	0133	0134	0135	0136
Page		26	27	26	27	26	27	26	27	26	27	28	29	26	27	26	27	34	34	34	34	34
<b>Function</b>	Overpressure	■	■	■	■	■	■	■	■	■	■	■	■	■	■	■	■	■	■	■	■	■
	Vacuum																					
	NO / NC	■	■	■	■	■	■	■	■	■	■	■	■	■	■	■	■					
	Changeover contacts																	■	■	■	■	■
<b>Voltage</b>	max. 42 V	■	■	■	■	■	■	■	■	■	■	■	■	■	■	■	■					
	max. 48 V																	■	■	■	■	■
	max. 250 V																					
	max. 24 V / 50 mA																					
<b>Adjustment range</b>	100 – 950 mbar																					
	200 – 950 mbar																					
	0,1 – 1 bar	■		■		■		■		■		■		■		■						
	0,2 – 2 bar																					
	0,3 – 1,5 bar																	■		■		■
	0,5 – 1 bar																					
	0,5 – 3 bar	■		■		■		■		■		■		■		■						
	0,5 – 5 bar																					
	1,0 – 6 bar																					
	1,0 – 10 bar	■		■		■		■		■		■		■		■		■		■		■
	2,0 – 20 bar																					
	5,0 – 50 bar																					
	10 – 20 bar	■		■		■		■		■		■		■		■						
	10 – 50 bar																	■		■		■
	10 – 100 bar																	■		■		■
	20 – 50 bar	■		■		■		■		■		■		■		■						
	20 – 100 bar																					
	25 – 250 bar																					
	40 – 400 bar																					
	50 – 100 bar																					
50 – 150 bar		■		■		■		■		■		■		■		■						
50 – 200 bar																		■		■		
100 – 200 (300) bar		■		■		■		■		■		■		■		■						
100 (200) – 400 bar																						
<b>Overpressure safety up to</b>	35 bar																					
	100 bar																					
	200 bar																					
	300 (400) bar	■		■		■		■		■		■		■		■		■		■		■
	600 (700) bar		■		■		■		■		■		■		■		■		■		■	
<b>Size</b>	hex 24	■	■	■	■	■	■	■	■	■	■	■	■	■	■	■	■					
	hex 27																	■	■	■	■	■
	30 A/F																					
<b>Housing material</b>	Zinc-platted steel	■	■	■	■	■	■	■	■	■	■	■	■	■	■	■	■	■	■	■	■	■
	stainless steel																					
	Brass																					
	Aluminium																					
<b>Custom variant</b>	ATEX																					
	Configurable																					
	additional functions																					
	cCSAus approval 	■	■	■	■	■	■	■	■	■	■	■	■	■	■	■	■	■	■	■	■	■

	M.2 hex 27 with int. connector					M.3 hex 24 NO / NC						M.4 hex 27 CO						M.5 hex 27 Configured								
	0137	0184	0185	0194	0195	0163	0164	0166	0167	0168	0169	0140	0141	0170	0171	0180	0181	0183	0186	0187	0190	0191	0196	0197	0240	0241
Page	34	36	37	38	39	42	48	44	50	46	47	55	55	56	56	57	57	58	59	59	60	60	61	61	65	65
Overpressure	■	■	■	■	■	■	■	■	■	■	■	■	■	■	■	■	■	■	■	■	■	■	■	■	■	■
Vacuum																										
NO / NC						■	■	■	■	■	■															
Changeover contacts	■	■	■	■	■							■	■	■	■	■	■	■	■	■	■	■	■	■	■	■
max. 42 V						■	■	■	■	■	■			■	■											
max. 48 V	■																									
max. 250 V		■	■									■	■			■	■	■	■	■						■
max. 24 V / 50 mA				■	■																■	■	■	■		
100 – 950 mbar																										
200 – 950 mbar																										
0,1 – 1 bar						■	■	■	■	■																
0,2 – 2 bar																										
0,3 – 1,5 bar		■		■								■		■		■			■		■		■		■	
0,5 – 1 bar																										
0,5 – 3 bar						■	■	■	■	■																
0,5 – 5 bar																			■				■			
1,0 – 6 bar																										
1,0 – 10 bar		■		■		■	■	■	■	■		■		■		■			■		■		■		■	
2,0 – 20 bar																										
5,0 – 50 bar																										
10 – 20 bar						■	■	■	■	■		■														■
10 – 50 bar		■		■										■		■			■		■		■			
10 – 100 bar		■		■										■		■			■		■		■			
20 – 50 bar						■	■	■		■		■														■
20 – 100 bar																										
25 – 250 bar																										
40 – 400 bar																										
50 – 100 bar																										
50 – 150 bar											■															■
50 – 200 bar	■		■		■										■					■		■		■		
100 – 200 (300) bar											■							■								
100 (200) – 400 bar																		■								
35 bar									■																	
100 bar		■		■										■		■					■					
200 bar																										
300 (400) bar		■		■				■		■		■		■		■			■		■		■		■	
600 (700) bar	■		■		■	■	■			■	■	■	■	■	■	■	■	■		■	■	■	■	■	■	■
hex 24						■	■	■	■	■	■															
hex 27	■	■	■	■	■							■	■	■	■	■	■	■	■	■	■	■	■	■	■	■
30 A/F																										
Zinc-platted steel	■	■	■	■	■	■		■		■	■	■	■	■	■	■	■	■			■	■				
stainless steel							■												■	■			■	■		
Brass									■																	
Aluminium																										
ATEX																										
Configurable						■	■	■	■	■	■	■	■	■	■	■	■	■	■	■	■	■	■	■	■	■
additional functions																										
cCSAus approval 	■	■	■	■	■	■	■	■	■	■	■			■	■	■	■	■	■	■	■	■	■	■	■	■

M.6 Pressure Switches PLUS hex 24 with intelligent electronic functions												M.7 hex 30 CO				M.8 ATEX Variant				M.9 Vacuum Switch		Page				
0410	0411	0412	0413	0414	0415	0416	0417	0418	0419	0422	0423	0424	0425	0159	0161	0162	0175	0165	0340	0341	0342	0343	0150	0151		
70	72	70	72	70	72	70	72	70	72	70	72	70	72	76	77	77	78	83	84	84	85	85	88	89		
■	■	■	■	■	■	■	■	■	■	■	■	■	■	■	■	■	■	■	■	■	■	■	■	■	Overpressure	Function
																							■	■	Vacuum	
■	■	■	■	■	■	■	■	■	■	■	■	■	■											■	NO / NC	
														■	■	■	■	■	■	■	■	■	■		Changeover contacts	
■	■	■	■	■	■	■	■	■	■	■	■	■	■											■	max. 42 V	Voltage
																									max. 48 V	
														■	■	■	■	■	■	■	■	■	■		max. 250 V	
																									max. 24 V / 50 mA	
																							■		100 – 950 mbar	Adjustment range
																							■		200 – 950 mbar	
■		■		■		■		■		■		■													0,1 – 1 bar	
														■											0,2 – 2 bar	
																									0,3 – 1,5 bar	
															■	■									0,5 – 1 bar	
																■	■								0,5 – 3 bar	
														■	■	■									0,5 – 5 bar	
																		■							1,0 – 6 bar	
■		■		■		■		■		■		■		■	■	■			■		■				1,0 – 10 bar	
														■											2,0 – 20 bar	
														■					■						5,0 – 50 bar	
■		■		■		■		■		■		■							■		■				10 – 20 bar	
															■	■									10 – 50 bar	
														■											10 – 100 bar	
■		■		■		■		■		■		■							■		■				20 – 50 bar	
																									20 – 100 bar	
														■					■						25 – 250 bar	
														■											40 – 400 bar	
															■	■									50 – 100 bar	
	■		■		■		■		■		■		■							■		■			50 – 150 bar	
																									50 – 200 bar	
																									100 – 200 (300) bar	
															■	■			■						100 (200) – 400 bar	
																	■						■	■	35 bar	Overpressure safety up to
																									100 bar	
														■	■	■			■						200 bar	
■		■		■		■		■		■		■							■		■				300 (400) bar	
	■		■		■		■		■		■		■	■	■	■				■	■	■			600 (700) bar	
■	■	■	■	■	■	■	■	■	■	■	■	■	■											■	hex 24	Size
																			■	■	■	■			hex 27	
														■	■	■	■							■	30 A/F	
■	■	■	■	■	■	■	■	■	■	■	■	■	■						■	■	■	■			Zinc-platted steel	Housing material
																									stainless steel	
																								■	Brass	
														■	■	■	■	■						■	Aluminium	
																		■	■	■	■	■			ATEX	Custom variant
																			■	■	■	■		■	Configurable	
■	■	■	■	■	■	■	■	■	■	■	■	■	■												additional functions	
																							■		cCSAus approval	

M.1  
hex 24 integrated

# Pressure switches hex 24 with integrated connector

NC or NO, maximum operating voltage up to 42 V



- Large selection of electrical plug-in types for quick attachment and reliable connection
- High protection class (to IP67 or IP6K9K)
- Compact and rugged design in industrial environments like construction and agricultural machinery or commercial vehicles
- Switching point can be set on site with adjusting screw in the connector<sup>1)</sup>
- High overpressure resistance, compact, small switches, available as normally open or normally closed
- Vacuum switches with integrated connector available on request

<sup>1)</sup> Pressure switches can also be supplied preset at factory.  
The switching point is embossed onto pressure switches preset at factory.

# The all-rounder with the broad selection of options

NC or NO, maximum operating voltage up to 42 V

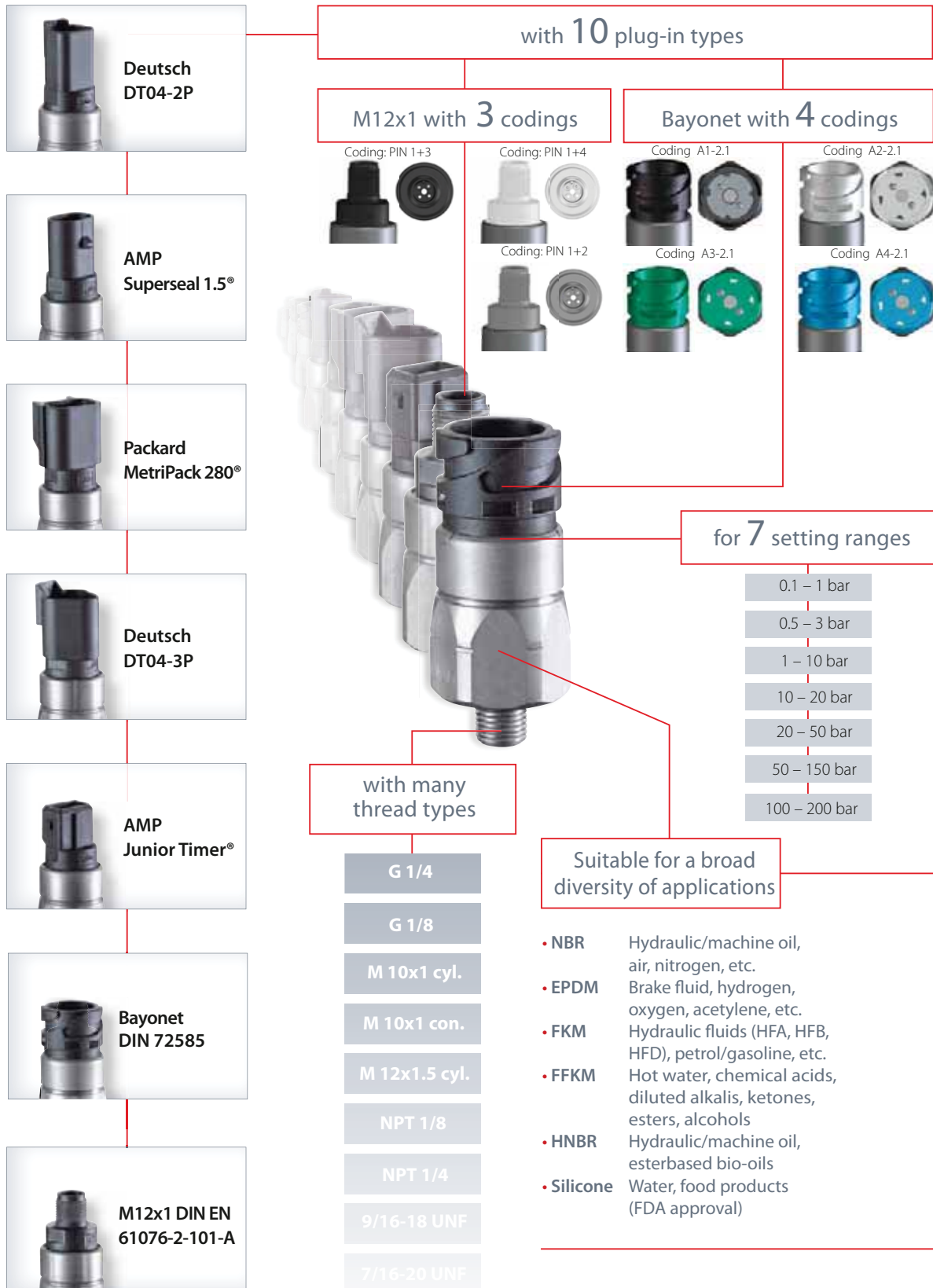

M.1  
hex 24 integrated

# Pressure switches hex 24 with integrated connector

## Technical details

- 

**0110 / 0111**  
Deutsch  
DT04-2P  
IP67, IP6K9K
- 

**0112 / 0113**  
AMP  
Superseal 1.5°  
IP67
- 

**0114 / 0115**  
Packard  
MetriPack 280°  
IP67
- 

**0116 / 0117**  
Deutsch  
DT04-3P  
IP67, IP6K9K
- 

**0118 / 0119**  
AMP  
Junior Timer®  
IP65, IPx4K
- 

**0120 / 0121**  
Bayonet  
DIN 72585  
IP67, IP6K9K
- 

**0122 / 0123**  
M12x1 DIN EN  
61076-2-101-A  
IP67
- 

**0124 / 0125**  
M12x1 DIN EN  
60947-5-2  
IP67

Rated working voltage:	10 ... 42 VAC/DC	
Rated current range (resistive load, DC12 / AC12):	10 mA ... 4 A	
Switching power DC12 / AC12:	100 W / 100 VA	
Temperature resistance of sealing materials:	NBR (diaphragm pressure switch)	-40 °F ... +212 °F (-40 °C ... +100 °C)
	NBR (piston pressure switch)	-22 °F ... +212 °F (-30 °C ... +100 °C)
	EPDM	-22 °F ... +248 °F (-30 °C ... +120 °C)
	FKM (diaphragm pressure switch)	+23 °F ... +248 °F (-5 °C ... +120 °C)
	FKM (piston pressure switch)	+5 °F ... +248 °F (-15 °C ... +120 °C)
	FFKM	-4 °F ... +248 °F (-20 °C ... +120 °C)
	Silicone	-40 °F ... +248 °F (-40 °C ... +120 °C)
	HNBR	-22 °F ... +248 °F (-30 °C ... +120 °C)
Burst pressure (diaphragm pressure switch):	400 bar	
Burst pressure (piston pressure switch)	700 bar (for threads M10, G 1/8, R 1/8 and NPT 1/8 up to max. 600 bar)	
Switching frequency:	200 / min	
Mechanical life expectancy:	1,000,000 cycles (for diaphragm pressure switches, life expectancy value only applies for switching pressures to max. 50 bar)	
Pressure rise rate:	≤ 1,000 bar/s	
Hysteresis:	Average value 5...30 % depending on type, not adjustable	
Vibration resistance:	10 g; 5...200 Hz sine wave, DIN EN 60068-2-6	
Shock resistance:	294 m/s <sup>2</sup> ; 14 ms half sine wave; DIN EN 60068-2-27	
Protection class:	Up to IP67 / IP6K9K according to manufacturer's specifications for the respective plug-in system only when plugged in, otherwise IP00	
Weight:	approx. 90 g	

### Contact assignment for bayonet connectors

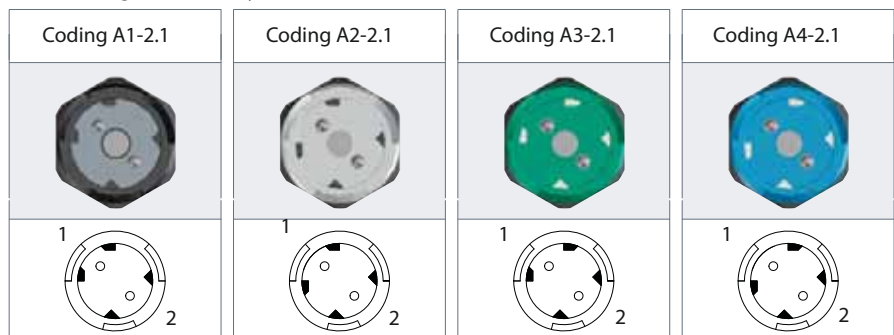

# 0110/0112/0114/0116/0118/0122/0124

## M.1

hex 24 integrated

### Diaphragm pressure switches with integrated connector

- Setting ranges to up to 725 psi (50 bar) (higher settings refer to page 26)
- NC or NO, maximum voltage 42 V
- Zinc-plated steel (Cr VI-free)
- Overpressure safety up to 4,350 psi (300 bar)

#### Plug-in types for diaphragm pressure switches

Deutsch DT04-2P	0110 - XXX XX - X - XXX	0110 - XXX XX - X - XXX
AMP Superseal 1.5°	0112 - XXX XX - X - XXX	0112 - XXX XX - X - XXX
Packard MetriPack 280°	0114 - XXX XX - X - XXX	0114 - XXX XX - X - XXX
Deutsch DT04-3P (A+B)	0116 - XXX XX - X - XXX	0116 - XXX XX - X - XXX
AMP Junior Timer°	0118 - XXX XX - X - XXX	0118 - XXX XX - X - XXX
M12x1 DIN EN 61076-2-101-A (PIN 1+3)	0122 - XXX XX - X - XXX	0122 - XXX XX - X - XXX
M12x1 DIN EN 60947-5-2 (PIN 1+2 / PIN 1+4)	0124 - XXX XX - X - XXX	0124 - XXX XX - X - XXX

Adjustment range tolerance at room temperature	Male thread	Order number NO → :	Order number NC → :
---	----------------	------------------------	------------------------

#### Diaphragm pressure switches with integrated connector

1.45 - 14.5 ± 2.90 psi (0.1 - 1 ± 0.2 bar)	M 10x1 taper	XXXX - 403 01 - X - 009	XXXX - 404 01 - X - 013
	M 12x1.5 cyl.	XXXX - 423 02 - X - 010	XXXX - 404 02 - X - 013
	1/4" BSPP	XXXX - 403 03 - X - 011	XXXX - 404 03 - X - 015
	1/8" BSPP	XXXX - 403 28 - X - 603	XXXX - 404 28 - X - 604
	1/4" NPT	XXXX - 403 09 - X - 345	XXXX - 404 09 - X - 346
	1/8" NPT	XXXX - 403 04 - X - 012	XXXX - 404 04 - X - 016
	7/16 - 20 UNF	XXXX - 403 20 - X - 305	XXXX - 404 20 - X - 307
	9/16 - 18 UNF	XXXX - 403 21 - X - 306	XXXX - 404 21 - X - 308

7.25 - 43.5 ± 4.35 psi (0.5 - 3 ± 0.3 bar)	M 10x1 taper	XXXX - 423 01 - X - 070	XXXX - 424 01 - X - 070
	M 12x1.5 cyl.	XXXX - 423 02 - X - 070	XXXX - 424 02 - X - 070
	1/4" BSPP	XXXX - 423 03 - X - 070	XXXX - 424 03 - X - 070
	1/8" BSPP	XXXX - 423 28 - X - 070	XXXX - 424 28 - X - 070
	1/4" NPT	XXXX - 423 09 - X - 070	XXXX - 424 09 - X - 070
	1/8" NPT	XXXX - 423 04 - X - 070	XXXX - 424 04 - X - 070
	9/16 - 18 UNF	XXXX - 423 20 - X - 070	XXXX - 424 20 - X - 070
	9/16 - 18 UNF	XXXX - 423 21 - X - 070	XXXX - 424 21 - X - 070

14.5 - 145 ± 7.25 psi (1 - 10 ± 0.5 bar)	M 10x1 taper	XXXX - 407 01 - X - 025	XXXX - 408 01 - X - 029
	M 12x1.5 cyl.	XXXX - 407 02 - X - 026	XXXX - 408 02 - X - 030
	1/4" BSPP	XXXX - 407 03 - X - 027	XXXX - 408 03 - X - 031
	1/8" BSPP	XXXX - 407 28 - X - 607	XXXX - 408 28 - X - 608
	1/4" NPT	XXXX - 407 09 - X - 349	XXXX - 408 09 - X - 350
	1/8" NPT	XXXX - 407 04 - X - 028	XXXX - 408 04 - X - 032
	7/16 - 20 UNF	XXXX - 407 20 - X - 313	XXXX - 408 20 - X - 315
	9/16 - 18 UNF	XXXX - 407 21 - X - 314	XXXX - 408 21 - X - 316

#### Seal material – Application areas

NBR (BunaN)	Hydraulic/machine oil, heating oil, air, nitrogen, etc.	1
EPDM	Brake fluid, hydrogen, oxygen, acetylene, etc.	2
FKM (Viton®)	Hydraulic fluids (HFA, HFB, HFD), petrol/gasoline, etc	3
FFKM	Hot water, chemical acids, diluted alkalis, ketones, esters, alcohols	6
HNBR	Hydraulic/machine oil, ester-based bio-oils	9

Refer to page 24 for the temperature range and application thresholds of sealing materials

Your order number:

01XX - XXX XX - X - XXX

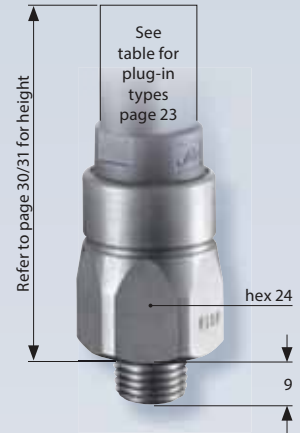

M



<sup>1)</sup> Static value. Dynamic value is 30-50 % lower. Values pertain to the hydraulic/pneumatic part of the pressure switch.

# M.1

hex 24 integrated



0122 Coding: PIN 1+3



0124 Coding: PIN 1+4 (NO)



0124 Coding: PIN 1+2 (NC)



# 0110/0112/0114/0116/0118/0122/0124

Diaphragm pressure switches with integrated connector

- Setting ranges up to 725 psi (50 bar) (lower settings refer to page 25)
- NC or NO, maximum operating voltage up to 42 V
- Zinc-plated steel (Cr VI-free)
- Overpressure safety up to 4,350 psi (300 bar)<sup>1)</sup>

## Plug-in types for diaphragm pressure switches

Deutsch DT04-2P	0110 - XXX XX - X - XXX	0110 - XXX XX - X - XXX
AMP Superseal 1.5°	0112 - XXX XX - X - XXX	0112 - XXX XX - X - XXX
Packard MetriPack 280°	0114 - XXX XX - X - XXX	0114 - XXX XX - X - XXX
Deutsch DT04-3P (A+B)	0116 - XXX XX - X - XXX	0116 - XXX XX - X - XXX
AMP Junior Timer°	0118 - XXX XX - X - XXX	0118 - XXX XX - X - XXX
M12x1 DIN EN 61076-2-101-A (PIN 1+3)	0122 - XXX XX - X - XXX	0122 - XXX XX - X - XXX
M12x1 DIN EN 60947-5-2 (PIN 1+2 / PIN 1+4)	0124 - XXX XX - X - XXX	0124 - XXX XX - X - XXX

Adjustment range tolerance at room temperature	Male thread	Order number NO →  :	Order number NC →  :
---	----------------	-------------------------	-------------------------

## Diaphragm pressure switches with integrated connector

145 - 290 ± 14.50 psi (10 - 20 ± 1.0 bar)	M 10x1 taper	XXXX - 411 01 - X - 041	XXXX - 412 01 - X - 045
	M 12x1.5 cyl.	XXXX - 411 02 - X - 042	XXXX - 412 02 - X - 046
	1/4" BSPP	XXXX - 411 03 - X - 043	XXXX - 412 03 - X - 047
	1/8" BSPP	XXXX - 411 28 - X - 611	XXXX - 412 28 - X - 612
	1/4" NPT	XXXX - 411 09 - X - 353	XXXX - 412 09 - X - 354
	1/8" NPT	XXXX - 411 04 - X - 044	XXXX - 412 04 - X - 048
	7/16-20 UNF	XXXX - 411 20 - X - 321	XXXX - 412 20 - X - 323
	9/16-18 UNF	XXXX - 411 21 - X - 322	XXXX - 412 21 - X - 324

290 - 725 ± 29.00 psi (20 - 50 ± 2.0 bar)	M 10x1 taper	XXXX - 415 01 - X - 057	XXXX - 416 01 - X - 061
	M 12x1.5 cyl.	XXXX - 415 02 - X - 058	XXXX - 416 02 - X - 062
	1/4" BSPP	XXXX - 415 03 - X - 059	XXXX - 416 03 - X - 063
	1/8" BSPP	XXXX - 415 28 - X - 615	XXXX - 416 28 - X - 616
	1/4" NPT	XXXX - 415 09 - X - 357	XXXX - 416 09 - X - 358
	1/8" NPT	XXXX - 415 04 - X - 060	XXXX - 416 04 - X - 064
	7/16-20 UNF	XXXX - 415 20 - X - 329	XXXX - 416 20 - X - 331
	9/16-18 UNF	XXXX - 415 21 - X - 330	XXXX - 416 21 - X - 332

## Seal material – Application areas

NBR (BunaN)	Hydraulic/machine oil, heating oil, air, nitrogen, etc.	1
EPDM	Brake fluid, hydrogen, oxygen, acetylene, etc.	2
FKM (Viton®)	Hydraulic fluids (HFA, HFB, HFD), petrol/gasoline, etc.	3
FFKM	FFKM Hot water, chemical acids, diluted alkalis, ketones, esters, alcohols	6
HNBR	Hydraulic/machine oil, ester-based bio-oils	9

Refer to page 24 for the temperature range and application thresholds of sealing materials.

Your order number:

01XX - XXX XX - X - XXX



<sup>1)</sup> Static value. Dynamic value is 30-50 % lower. Values pertain to the hydraulic/pneumatic part of the pressure switch.

# 0111 / 0113 / 0115 / 0117 / 0119 / 0123 / 0125

## Piston pressure switches with integrated connector

- Setting range up to 2,175 psi (150 bar)
- NC or NO, maximum operating voltage up to 42 V
- Zinc-plated steel (Cr VI-free)
- Overpressure safety up to 8,700 psi (600 bar)<sup>1)</sup>

### Plug-in types for piston pressure switches

Deutsch DT04-2P	0111 - XXX XX - X - XXX	0111 - XXX XX - X - XXX
AMP Superseal 1.5°	0113 - XXX XX - X - XXX	0113 - XXX XX - X - XXX
Packard MetriPack 280°	0115 - XXX XX - X - XXX	0115 - XXX XX - X - XXX
Deutsch DT04-3P (A+B)	0117 - XXX XX - X - XXX	0117 - XXX XX - X - XXX
AMP Junior Timer®	0119 - XXX XX - X - XXX	0119 - XXX XX - X - XXX
M12x1 DIN EN 61076-2-101-A (PIN 1+3)	0123 - XXX XX - X - XXX	0123 - XXX XX - X - XXX
M12x1 DIN EN 60947-5-2 (PIN 1+2 / PIN 1+4)	0125 - XXX XX - X - XXX	0125 - XXX XX - X - XXX

Adjustment range tolerance at room temperature	Male thread	Order number NO →  :	Order number NC → :
---	----------------	-------------------------	------------------------

### Piston pressure switches with integrated connector

725 - 2,175±72.5 psi (50 - 150 ± 5 bar)	M 10x1 taper	XXXX - 419 01 - X - 009	XXXX - 420 01 - X - 013
	M 12x1.5 cyl.	XXXX - 419 02 - X - 010	XXXX - 420 02 - X - 014
	1/4" BSPP	XXXX - 419 03 - X - 011	XXXX - 420 03 - X - 015
	1/8" BSPP	XXXX - 419 28 - X - 603	XXXX - 420 28 - X - 604
	1/4" NPT	XXXX - 419 09 - X - 311	XXXX - 420 09 - X - 312
	1/8" NPT	XXXX - 419 04 - X - 012	XXXX - 420 04 - X - 016
	7/16-20 UNF	XXXX - 419 20 - X - 305	XXXX - 420 20 - X - 307
	9/16-18 UNF	XXXX - 419 21 - X - 306	XXXX - 420 21 - X - 308

1,450 - 2,900 ±72.5 psi (100 - 200 ± 5 bar)	G 1/4 DIN 3852-2-A	XXXX - 493 60 - X - 011	XXXX - 494-60- X - 015
	M 12x1.5 DIN 3852-1-A	XXXX - 493 68 - X - 010	XXXX - 494-68- X - 014

### Seal material – Application areas

NBR (BunaN)	Hydraulic/machine oil, heating oil, air, nitrogen, etc.	1
EPDM	Brake fluid, hydrogen, oxygen, acetylene, etc.	2
FKM	Hydraulic fluids (HFA, HFB, HFD), petrol/gasoline, etc.	3
HNBR	Hydraulic/machine oil, ester-based bio-oils	9

Refer to page 24 for the temperature range and application thresholds of sealing materials.

Your order number: 01XX - XXX XX - X - XXX

# M.1

hex 24 integrated

See table  
for plug-in  
types  
page 23



0123 Coding: PIN 1+3



Coding: PIN 1+4 (NO)



Coding: PIN 1+2 (NC)



<sup>1)</sup> Static value. Dynamic value is 30-50 % lower. Values pertain to the hydraulic/pneumatic part of the pressure switch.

# M.1

hex 24 integrated

Bayonet ISO 15170  
(DIN 72585)



# 0120

Diaphragm pressure switches with integrated bayonet connector

- NC or NO, maximum operating voltage up to 42 V
- Zinc-plated steel (Cr VI-free)
- Overpressure safety up to 4,350 psi (300 bar)<sup>1)</sup>

Adjustment range tolerance at room temperature	Male thread	Order number NO →  :	Order number NC → :
---	----------------	-------------------------	------------------------

0120 Diaphragm pressure switches with integrated connector

1.45 - 14.5 ±2.90 psi (0.1 - 1 ±0.2 bar)	M 10x1 taper	0120 - X03 01 - X - 009	0120 - X04 01 - X - 013
	M 12x1.5 cyl.	0120 - X03 02 - X - 010	0120 - X04 02 - X - 014
	1/4" BSPP	0120 - X03 03 - X - 011	0120 - X04 03 - X - 015
	1/8" BSPP	0120 - X03 28 - X - 011	0120 - X04 28 - X - 604
	1/4" NPT	0120 - X03 09 - X - 345	0120 - X04 09 - X - 346
	1/8" NPT	0120 - X03 04 - X - 012	0120 - X04 04 - X - 016
	7/16-20 UNF 9/16-18 UNF	0120 - X03 20 - X - 305 0120 - X03 21 - X - 306	0120 - X04 20 - X - 307 0120 - X04 21 - X - 308
7.25 - 43.5 ±4.35 psi (0.5 - 3 ±0.3 bar)	M 10x1 taper	0120 - X23 01 - X - 070	0120 - X24 01 - X - 070
	M 12x1.5 cyl.	0120 - X23 02 - X - 070	0120 - X24 02 - X - 070
	1/4" BSPP	0120 - X23 03 - X - 070	0120 - X24 03 - X - 070
	1/8" BSPP	0120 - X23 28 - X - 070	0120 - X24 28 - X - 070
	1/4" NPT	0120 - X23 09 - X - 070	0120 - X24 09 - X - 070
	1/8" NPT	0120 - X23 04 - X - 070	0120 - X24 04 - X - 070
	7/16-20 UNF 9/16-18 UNF	0120 - X23 20 - X - 070 0120 - X23 21 - X - 070	0120 - X24 20 - X - 070 0120 - X24 21 - X - 070
14.5 - 145 ±7.25 psi (1 - 10 ±0.5 bar)	M 10x1 taper	0120 - X07 01 - X - 025	0120 - X08 01 - X - 029
	M 12x1.5 cyl.	0120 - X07 02 - X - 026	0120 - X08 02 - X - 030
	1/4" BSPP	0120 - X07 03 - X - 027	0120 - X08 03 - X - 031
	1/8" BSPP	0120 - X07 28 - X - 607	0120 - X08 28 - X - 608
	1/4" NPT	0120 - X07 09 - X - 349	0120 - X08 09 - X - 350
	1/8" NPT	0120 - X07 04 - X - 028	0120 - X08 04 - X - 032
	7/16-20 UNF 9/16-18 UNF	0120 - X07 20 - X - 313 0120 - X07 21 - X - 314	0120 - X08 20 - X - 315 0120 - X08 21 - X - 316

Coding

A1-2.1	4XX	4XX
A2-2.1	3XX	3XX
A3-2.1	2XX	2XX
A4-2.1	1XX	1XX

Seal material – Application areas

NBR (BunaN)	Hydraulic/machine oil, heating oil, air, nitrogen, etc.	1
EPDM	Brake fluid, hydrogen, oxygen, acetylene, etc.	2
FKM (Viton®)	Hydraulic fluids (HFA, HFB, HFD), petrol/gasoline, etc.	3
FFKM	Hot water, chemical acids, diluted alkalis, ketones, esters, alcohols	6
HNBR	Hydraulic/machine oil, ester-based bio-oils	9

Refer to page 24 for the temperature range an

Your order number: 0120 - XXX XX - X - XXX

<sup>1)</sup> Static value. Dynamic value is 30-50 % lower. Values pertain to the hydraulic/pneumatic part of the pressure switch.



# 0120 /0121

## Diaphragm/piston pressure switches with integrated bayonet

- NC or NO, maximum operating voltage up to 42 V
- Zinc-plated steel (Cr VI-free)
- Overpressure safety up to 4,350 psi (300 bar)<sup>1)</sup> for diaphragm variant
- Overpressure safety up to 8,700 psi (600 bar)<sup>1)</sup> for piston variant

Adjustment range tolerance at room temperature	Male thread	Order number NO → :	Order number NC → :
---	----------------	------------------------	------------------------

### 0120 Diaphragm pressure switches with integrated connector

145 - 290 ± 14.50 psi (10 - 20 ± 1.0 bar)	M 10x1 taper	0120 - X11 01 - X - 041	0120 - X12 01 - X - 045
	M 12x1.5 cyl.	0120 - 11 02 - X - 042	0120 - X12 02 - X - 046
	1/4" BSPP	0120 - X11 03 - X - 043	0120 - X12 03 - X - 047
	1/8" BSPP	0120 - 11 28 - X - 611	0120 - 12 28 - X - 612
	1/4" NPT	0120 - X11 09 - X - 353	0120 - X12 09 - X - 354
	1/8" NPT	0120 - X11 04 - X - 044	0120 - X12 04 - X - 048
	7/16-20 UNF	0120 - X11 20 - X - 321	0120 - X12 20 - X - 323
9/16-18 UNF	0120 - X11 21 - X - 322	0120 - X12 21 - X - 324	

290 - 725 ± 29.0 psi (20 - 50 ± 2.0 bar)	M 10x1 taper	0120 - X15 01 - X - 057	0120 - X16 01 - X - 061
	M 12x1.5 cyl.	0120 - X15 02 - X - 058	0120 - X16 02 - X - 062
	1/4" BSPP	0120 - X15 03 - X - 059	0120 - X16 03 - X - 063
	1/8" BSPP	0120 - 15 28 - X - 615	0120 - 16 28 - X - 616
	1/4" NPT	0120 - X15 09 - X - 357	0120 - X16 09 - X - 358
	1/8" NPT	0120 - X15 04 - X - 060	0120 - X16 04 - X - 064
	7/16-20 UNF	0120 - X15 20 - X - 329	0120 - X16 20 - X - 331
9/16-18 UNF	0120 - X15 21 - X - 330	0120 - X16 21 - X - 332	

### 0121 Piston pressure switches with integrated connector

725 - 2,175 ± 72.5 psi (50 - 150 ± 5.0 bar)	M 10x1 taper	0121 - X19 01 - X - 009	0121 - X20 01 - X - 013
	M 12x1.5 cyl.	0121 - X19 02 - X - 010	0121 - X20 02 - X - 014
	1/4" BSPP	0121 - X19 03 - X - 011	0121 - X20 03 - X - 015
	1/8" BSPP	0121 - X19 28 - X - 603	0121 - X20 28 - X - 604
	1/4" NPT	0121 - X19 09 - X - 311	0121 - X20 09 - X - 312
	1/8" NPT	0121 - X19 04 - X - 012	0121 - X20 04 - X - 016
	7/16-20 UNF	0121 - X19 20 - X - 305	0121 - X20 20 - X - 307
9/16-18 UNF	0121 - X19 21 - X - 306	0121 - X20 21 - X - 308	

1,450 - 2,900 ± 72.5 psi (100 - 200 ± 5 bar)	G 1/4 DIN 3852-2-A	0121 - X 93 60 - X - 011	0121 - X 94 60 - X - 015
	M 12x1.5 DIN 3852-1-A	0121 - X 93 68 - X - 010	0121 - X 94 68 - X - 014

### Coding

A1-2.1	4XX	4XX
A2-2.1	3XX	3XX
A3-2.1	2XX	2XX
A4-2.1	1XX	1XX

### Seal material – Application areas

NBR (BunaN)	Hydraulic/machine oil, heating oil, air, nitrogen, etc.	1
EPDM	Brake fluid, hydrogen, oxygen, acetylene, etc.	2
FKM (Viton®)	Hydraulic fluids (HFA, HFB, HFD), petrol/gasoline, etc.	3
FFKM	Hot water, chemical acids, diluted alkalis, ketones, esters, alcohols	6
HNBR	Hydraulic/machine oil, ester-based bio-oils	9

Refer to page 24 for the temperature range and application thresholds of sealing materials.

Your order number: 012X - XXX XX - X - XXX

<sup>1)</sup> Static value. Dynamic value is 30-50 % lower. Values pertain to the hydraulic/pneumatic part of the pressure switch.

# M.1

hex 24 integrated

Coding A1-2.1



Coding A2-2.1



Coding A3-2.1





Coding A4-2.1







# Technical details, contact assignment & accessories

for hex 24 pressure switches with integrated connector

**Please note:**  
Mating plugs are not included in the delivery and can be ordered separately.

Mating plug accessories <sup>1)</sup>			
<b>Mating plug type</b> ▶	<b>Deutsch DT04-2P (for DT06-2S)</b>	<b>AMP Superseal 1.5®</b>	<b>Packard MetriPack 280®</b>
<b>Including 2 m cable</b> ▶			
<b>Cable cross-section</b> ▶	2 x 0,5 mm <sup>2</sup> Radox cables	2 x 0,5 mm <sup>2</sup> Radox cables	2 x 0,5 mm <sup>2</sup> Radox cables
<b>Protection class</b> ▶	IP65	IP65	IP65
<b>Article number</b> ▶	<b>1-1-10-653-118</b>	<b>1-1-12-653-113</b>	<b>1-1-14-653-114</b>

<sup>1)</sup> For the pin assignment of the wires please refer to chapter M.10 Accessories (page 91)

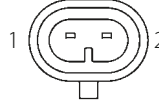
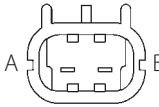
Plug-in types for hex 24 diaphragm and piston pressure switches			
<b>Model / Type</b> ▶	<b>0110 / 0111</b>	<b>0112 / 0113</b>	<b>0114 / 0115</b>
			
<b>Connector</b> ▶	<b>Deutsch DT04-2P</b>	<b>AMP Superseal 1.5®</b>	<b>Packard MetriPack 280®</b>
<b>Protection class</b> ▶	IP67, IP6K9K	IP67	IP67
<b>Overall height</b> ▶	H ≈ 61 mm	H ≈ 61 mm	H ≈ 62 mm
<b>Contact assignment</b> ▶			

<b>Deutsch DT04-3P (for DT04-3P)</b>	<b>AMP Junior Timer®</b>	<b>Bayonet DIN 72585/ISO 15170 A1-2.1</b>	<b>M12x1 DIN EN 61076-2-101-LF (A)</b>
2 x 0,5 mm <sup>2</sup> PUR cables	2 x 0,5 mm <sup>2</sup> Radox cables	2 x 0,5 mm <sup>2</sup> Radox cables	4 x 0,34 mm <sup>2</sup> PUR cables
IP67	IP65	IP65	IP67
<b>1-1-36-653-160</b>	<b>1-1-18-653-116</b>	<b>1-1-20-653-112</b>	<b>1-1-00-653-162</b>

<b>0116 / 0117</b>	<b>0118 / 0119</b>	<b>0120 / 0121</b>	<b>0122 / 0123</b>	<b>0124 / 0125</b>
<b>Deutsch DT04-3P</b>	<b>AMP Junior Timer®</b>	<b>Bayonet DIN 72585/ISO 15170</b>	<b>M12x1 DIN EN 61076-2-101-A</b>	<b>M12x1 DIN EN 60947-5-2</b>
IP67, IP6K9K	IP65, IPx4K	IP67, IP6K9K	IP67	IP67
H ≈ 63 mm	H ≈ 54 mm	H ≈ 49 mm	H ≈ 51 mm	H ≈ 51 mm
		 Coding: A1-2.1	 NO / NC (black) 1: brown 3: blue	 NO (light grey)    NC (dark grey) 1: brown 2: black 4: white

# Pressure switches hex 27 with integrated connector

Changeover switch with silver or gold contacts



- Large selection of electrical plug-in types for quick attachment and reliable connection
- Hysteresis adjustable at factory
- High protection class (to IP67 or IP6K9K)
- Compact and rugged design in industrial environments like construction and agricultural machinery or commercial vehicles
- Switching point can be set on site with adjusting screw<sup>1)</sup>
- Very high overpressure safety
- Corresponding mating plugs are available as accessories (please refer to page 34)

<sup>1)</sup> Pressure switches can also be supplied preset at factory.  
The switching point is embossed onto pressure switches preset at factory.

# Pressure switches hex 27 with integrated connector

## M.2

hex 27 integrated

### Technical details

Types:	0132-0137	0184 / 0185	0194 / 0195
Rated working voltage:	10 ... 48 VAC/DC	10 ... 250 VAC/DC	5 ... 24 VDC
Rated current: (resistive load, DC12 / AC12)	10 mA ... 4 A	10 mA ... 4 A	3 ... 50 mA
Temperature resistance of sealing materials:	NBR (diaphragm pressure switch, p <sub>max</sub> = 5,800 psi / 400 bar)	-22 °F ... +212 °F (-40 °C ... +100 °C)	
	NBR (diaphragm pressure switch, p <sub>max</sub> = 1,450 psi / 100 bar) (piston pressure switch)	-40 °F ... +212 °F (-30 °C ... +100 °C)	
	EPDM	-22 °F ... +248 °F (-30 °C ... +120 °C)	
	FKM (diaphragm pressure switch)	+23 °F ... +248 °F (-5 °C ... +120 °C)	
	FKM (piston pressure switch)	+5 °F ... +248 °F (-15 °C ... +120 °C)	
	FFKM	-4 °F ... +248 °F (-20 °C ... +120 °C)	
	Silicone	-40 °F ... +248 °F (-40 °C ... +120 °C)	
	HNBR	-22 °F ... +248 °F (-30 °C ... +120 °C)	
Burst pressure (diaphragm pressure switch, overpressure resistance 1,450 psi)	2,900 psi (200 bar)		
Burst Pressure (diaphragm pressure switch, overpressure resistance 5,800 psi)	10,153 psi (700 bar) for threads M10, G 1/8, R 1/8 and NPT 1/8 up to max. 8,700 psi (600 bar)		
Burst pressure (Piston pressure switch)	14,500 psi (1,000 bar) for threads M10, G 1/8, R 1/8 and NPT 1/8 up to max. 8,700 psi (600 bar)		
Switching frequency:	200 / min		
Mechanical life expectancy:	1,000,000 cycles - for diaphragm pressure switches, life expectancy value only applies for switching pressures to max. 725 psi (50 bar)		
Pressure rise rate:	≤ 1 bar/ms		
Hysteresis: (can only be set at factory) <sup>1)</sup> :	Adjustable average value 10 ... 30 % depending on type		
Vibration resistance:	10 g; 5 ... 200 Hz sine wave; DIN EN 60068-2-6		
Shock resistance:	294 m/s <sup>2</sup> ; 14 ms half sine wave; DIN EN 60068-2-27		
Weight:	approx. 100 g	approx. 130 g	approx. 130 g

### Overview of maximum working voltage and current and contact materials

Type:	0132	0133	0134	0135	0136	0137	0184	0185	0194	0195
5 ... 24 VDC									●	●
10 ... 48 VAC/DC	●	●	●	●	●	●				
10 ... 250 VAC/DC							●	●		
3 ... 50 mA									●	●
10 mA ... 4 A	●	●	●	●	●	●	●	●		
Gold contacts	○	○	○	○	○	○			●	●
Silver contacts	●	●	●	●	●	●	●	●		
Adjustable hysteresis (can only be set at factory)	●	●	●	●	●	●	●	●	●	●
Connector type	AMP Superseal 1.5 <sup>®</sup>		M12x1 DIN EN 61076-2-101-A		Deutsch DT04-3P		DIN EN 175301			
Protection class	IP67		IP67		IP67, IP6K9K		IP65			

<sup>1)</sup> see notes on hysteresis in the technical explanations (page 15-16)

# M.2

hex 27 integrated

## 0132 / 0133 / 0134 / 0135 / 0136 / 0137

Diaphragm/piston pressure switches with integrated connector, maximum operating voltage up to 48 V

- Simple, quick and reliable electrical connection with easy-to-fit connectors
- Quick fitting with socket wrench (spanner)
- Changeover with silver contacts (gold contacts available as option)
- Hysteresis adjustable at factory
- Made of zinc-plated steel (CrVI-free, other housing materials available as option)

Model / type ▶

Height without thread ▶

Contact assignments ▶

Circuit diagrams ▶



Accessory ▶

Not included in the delivery.

Please order separately.

Cable cross-section / IP protection ▶

Article number ▶

0132 / 0133	0134 / 0135	0136 / 0137
		
TE AMP Superseal 1.5° IP67	M12x1 EN 61076-2-101-A Contact assignment DIN 60947-5-2 IP67	Deutsch DT04-3P® IP67, IP6K9K
H ≈ 73 mm	H ≈ 65 mm	H ≈ 71 mm

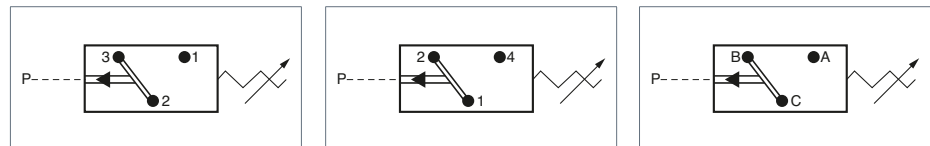
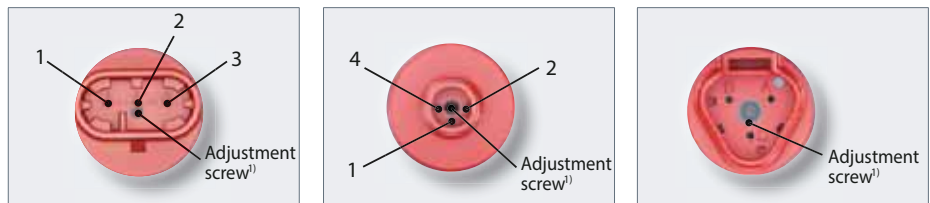

<sup>1)</sup> Blade of screwdriver max. 2 mm

Mating plug with 2 m cable <sup>2)</sup>

TE AMP Superseal 1.5°	M12x1 DIN EN 61076-2-101-LF	Deutsch DT06-3S®
		
3 x 0,5 mm <sup>2</sup> Radox cable / IP65	4 x 0,34 mm <sup>2</sup> PUR cable / IP67	3 x 0,5 mm <sup>2</sup> PUR cable / IP67
1-1-32-653-158	1-1-00-653-162	1-1-36-653-160

<sup>2)</sup> For the pin assignment of the wires please refer to chapter M.10 Accessories (page 91)

# 0132 / 0133 / 0134 / 0135 / 0136 / 0137

Diaphragm/piston pressure switches with integrated connector, maximum operating voltage up to 48 V

M.2  
hex 27 integrated

$p_{max}$ in psi/bar	Adjustment range in bar	Tolerance at room temperature in bar	Thread	Article number
-------------------------	----------------------------	---	--------	----------------

## 0132 / 0134 / 0136 Diaphragm pressure switches

1,450 psi (100 bar)	4.35 - 21.75 psi (0.3 - 1.5 bar)	$\pm 2.90$ psi ( $\pm 0.2$ bar)	1/4" BSPP	013X - 457 03 - X - 003
			M 10x1 taper	013X - 457 01 - X - 001
			M12x1.5 cyl.	013X - 457 02 - X - 002
			1/4" NPT	013X - 457 09 - X - 314
			1/8" NPT	013X - 457 04 - X - 318
			7/16-20 UNF	013X - 457 20 - X - 301
			9/16-18 UNF	013X - 457 21 - X - 302
			1/4" BSPP	013X - 458 03 - X - 042
			M 10x1 taper	013X - 458 01 - X - 040
			M12x1.5 cyl.	013X - 458 02 - X - 041
			1/4" NPT	013X - 458 09 - X - 340
			1/8" NPT	013X - 458 04 - X - 343
5,801 psi (400 bar)	14.5 - 145 psi (1 - 10 bar)	$\pm 7.25$ psi ( $\pm 0.5$ bar)	7/16-20 UNF	013X - 458 20 - X - 341
			9/16-18 UNF	013X - 458 21 - X - 342
			1/4" BSPP	013X - 459 03 - X - 009
			M 10x1 taper	013X - 459 01 - X - 007
			M12x1.5 cyl.	013X - 459 02 - X - 008
			1/4" NPT	013X - 459 09 - X - 316
5,801 psi (400 bar)	145 - 725 psi (10 - 50 bar)	$\pm 43.5$ psi ( $\pm 3.0$ bar)	1/8" NPT	013X - 459 04 - X - 320
			7/16-20 UNF	013X - 459 20 - X - 305
			9/16-18 UNF	013X - 459 21 - X - 306
			1/4" BSPP	013X - 461 03 - X - 012
			M 10x1 taper	013X - 461 01 - X - 010
			M12x1.5 cyl.	013X - 461 02 - X - 011
10,152 psi (700 bar)	145 - 1,450 psi (10 - 100 bar)	$\pm 43.5 - 72.5$ psi ( $\pm 3.0 - 5.0$ bar)	1/4" NPT	013X - 461 09 - X - 317
			1/8" NPT	013X - 461 04 - X - 321
			7/16-20 UNF	013X - 461 20 - X - 307
			9/16-18 UNF	013X - 461 21 - X - 308

## 0133 / 0135 / 0137 Piston pressure switches

10,152 psi (700 bar)	725 - 2,900 psi (50 - 200 bar)	$\pm 72.5$ psi ( $\pm 5.0$ bar)	1/4" BSPP	013X - 460 03 - X - 003
			M 10x1 taper	013X - 460 01 - X - 001
			M12x1.5 cyl.	013X - 460 02 - X - 002
			1/4" NPT	013X - 460 09 - X - 303
			1/8" NPT	013X - 460 04 - X - 304
			7/16-20 UNF	013X - 460 20 - X - 301
			9/16-18 UNF	013X - 460 21 - X - 302

### Seal material – Application areas

NBR	Hydraulic/machine oil, air, nitrogen, etc.	1
EPDM	Brake fluid, hydrogen, oxygen, acetylene, etc.	2
FKM	Hydraulic fluids (HFA, HFB, HFD), petrol/gasoline, etc.	3
FFKM	Hot water, chemical acids, diluted alkalis, ketones, esters, alcohols	6
HNBR <sup>3)</sup>	Hydraulic/machine oil, ester-based bio-oils	9

Refer to page 33 for the temperature range and application thresholds of sealing materials.

Article number: 013 X - XXX XX - X - XXX

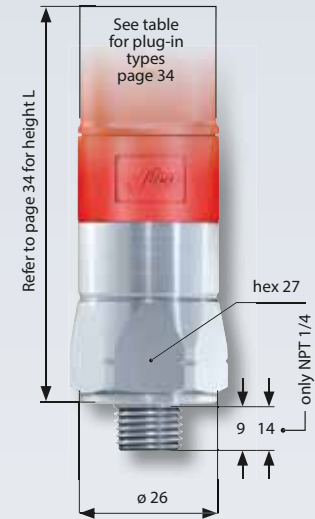

<sup>1)</sup> Static value. Dynamic value is 30-50 % lower. Values pertain to the hydraulic/pneumatic part of the pressure switch.

<sup>2)</sup> Excluding the thread sizes G 1/8, R 1/8, NPT 1/8 and M10x1 cylindrical/conical.

<sup>3)</sup> HNBR diaphragm not available for pressure ranges 0.3 - 1.5 bar.



# M.2

hex 27 integrated

# 0184

Diaphragm pressure switches up to 250 V

- Made of zinc-plated steel (CrVI-free, other housing materials available as option)
- Socket device similar to DIN EN 175301 (DIN 43650)
- Snap action with silver contacts
- Overpressure safety up to 1,450 / 5,801 psi (100 / 400 bar)<sup>1)</sup>
- Differential adjustable at factory

P <sub>max.</sub> in psi (bar)	Adjustment range in psi (bar)	Tolerance in psi (bar) at room temperature	Male thread	Order number
-----------------------------------	----------------------------------	---	-------------	--------------

### 0184 Diaphragm pressure switches

1,450 psi <sup>1)</sup> (100 bar)	4.35 - 21.75 psi (0.3 - 1.5 bar)	± 2.90 psi (± 0.2 bar)	M 10x1 taper	0184 - 457 01 - X - 001
			M 12x1.5 cyl.	0184 - 457 02 - X - 002
			1/4" BSPP	0184 - 457 03 - X - 003
			1/4" NPT	0184 - 457 09 - X - 314
			1/8" NPT	0184 - 457 04 - X - 318
			7/16-20 UNF	0184 - 457 20 - X - 301
			9/16-18 UNF	0184 - 457 21 - X - 302

	14.5 - 145 psi (1 - 10 bar)	± 7.25 psi (± 0.5 bar)	M 10x1 taper	0184 - 458 01 - X - 040
			M 12x1.5 cyl.	0184 - 458 02 - X - 041
			1/4" BSPP	0184 - 458 03 - X - 042
			1/4" NPT	0184 - 458 09 - X - 340
			1/8" NPT	0184 - 458 04 - X - 343
			7/16-20 UNF	0184 - 458 20 - X - 341
			9/16-18 UNF	0184 - 458 21 - X - 342

5,801 psi <sup>1)</sup> (400 bar)	145 - 725 psi (10 - 50 bar)	± 43.5 psi (± 3.0 bar)	M 10x1 taper	0184 - 459 01 - X - 007
			M 12x1.5 cyl.	0184 - 459 02 - X - 008
			1/4" BSPP	0184 - 459 03 - X - 009
			1/4" NPT	0184 - 459 09 - X - 311
			1/8" NPT	0184 - 459 04 - X - 320
			7/16-20 UNF	0184 - 459 20 - X - 305
			9/16-18 UNF	0184 - 459 21 - X - 306

	145 - 1,450 psi (10 - 100 bar)	± 43.5 - 72.5 psi (± 3.0 - 5.0 bar)	M 10x1 taper	0184 - 461 01 - X - 010
			M 12x1.5 cyl.	0184 - 461 02 - X - 011
			1/4" BSPP	0184 - 461 03 - X - 012
			1/4" NPT	0184 - 461 09 - X - 312
			1/8" NPT	0184 - 461 04 - X - 321
			7/16-20 UNF	0184 - 461 20 - X - 307
			9/16-18 UNF	0184 - 461 21 - X - 308



Socket device included in the delivery

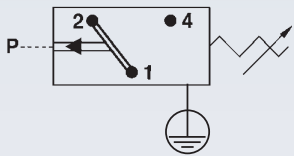

### Seal material – Application areas

NBR (BunaN)	Hydraulic/machine oil, heating oil, air, nitrogen, etc.	1
EPDM	Brake fluid, hydrogen, oxygen, acetylene, etc.	2
FKM(Viton®)	Hydraulic fluids (HFA, HFB, HFD), petrol/gasoline, etc.	3
FFKM	Hot water, chemical acids, diluted alkalis, ketones, esters, alcohols	6
HNBR	Hydraulic/machine oil, ester-based bio-oils	9

Refer to page 33 for the temperature range and application thresholds of sealing materials.



Your order number: 0184 - XXX XX - X - XXX



<sup>1)</sup> Static value. Dynamic value is 30-50 % lower. Values pertain to the hydraulic/pneumatic part of the pressure switch.

# 0185

## Piston pressure switches up to 250 V

- Made of zinc-plated steel (CrVI-free, other housing materials available as option)
- Socket device similar to DIN EN 175301 (DIN 43650)
- Snap action with silver contacts
- Overpressure safety up to 10,152 psi (700 bar)<sup>1)</sup>
- Differential adjustable at factory

P <sub>max.</sub> in psi (bar)	Adjustment range in psi (bar)	Tolerance in psi (bar) at room temperature	Male thread	Order number
-----------------------------------	----------------------------------	---	-------------	--------------

### 0185 Piston pressure switches

10,152 psi <sup>1)</sup> (700 bar) <sup>1)</sup>	725 - 2,900 psi (50 - 200 bar)	± 72.5 psi (± 5.0 bar)	M 10x1 taper	0185 - 460 01 - X - 001
			M 12x1.5 cyl.	0185 - 460 02 - X - 002
			1/4" BSPP	0185 - 460 03 - X - 003
			1/4" NPT	0185 - 460 09 - X - 303
			7/16-20 UNF	0185 - 460 20 - X - 301
			9/16-18 UNF	0185 - 460 21 - X - 302

### Seal material – Application areas

NBR (BunaN)	Hydraulic/machine oil, heating oil, air, nitrogen, etc.	1
EPDM	Brake fluid, hydrogen, oxygen, acetylene, etc.	2
FKM (Viton®)	Hydraulic fluids (HFA, HFB, HFD), petrol/gasoline, etc.	3
HNBR	Hydraulic/machine oil, ester-based bio-oils	9

Refer to page 33 for the temperature range and application thresholds of sealing materials.

Your order number: 0185 - 460 XX - X - XXX

# M.2

hex 27 integrated



Socket device included in the delivery

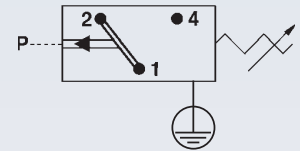

<sup>1)</sup> Static value. Dynamic value is 30-50 % lower. Values pertain to the hydraulic/pneumatic part of the pressure switch.

# M.2

hex 27 integrated



Socket device included in the delivery



# 0194

Diaphragm pressure switches up to 24 V with gold contacts

- Made of zinc-plated steel (CrVI-free)
- Socket device similar to DIN EN 175301 (DIN 43650)
- Changeover with gold contacts
- Overpressure safety up to 1,450 / 5,800 psi (100 / 400 bar)<sup>1)</sup>
- Hysteresis adjustable at factory

p <sub>max</sub> in bar	Adjustment range in bar	Tolerance at room temperature in bar	Male thread	Article number
-------------------------	-------------------------	--------------------------------------	-------------	----------------

### 0194 Diaphragm pressure switches

p <sub>max</sub> in bar	Adjustment range in bar	Tolerance at room temperature in bar	Male thread	Article number	
1,450 psi <sup>1)</sup> (100 bar)	0.3 - 1.5	± 0.2	1/4" BSP	0194 - 457 03 - X - 003	
			M 10x1 con.	0194 - 457 01 - X - 001	
			M 12x1.5 cyl.	0194 - 457 02 - X - 002	
			1/4" NPT	0194 - 457 09 - X - 314	
			1/8" NPT	0194 - 457 04 - X - 318	
			7/16-20 UNF	0194 - 457 20 - X - 301	
			9/16-18 UNF	0194 - 457 21 - X - 302	
5,800 psi <sup>1)</sup> (400 bar)	1 - 10	± 0.5	1/4" BSP	0194 - 458 03 - X - 042	
			M 10x1 con.	0194 - 458 01 - X - 040	
			M 12x1.5 cyl.	0194 - 458 02 - X - 041	
			1/4" NPT	0194 - 458 09 - X - 340	
			1/8" NPT	0194 - 458 04 - X - 343	
			7/16-20 UNF	0194 - 458 20 - X - 341	
				9/16-18 UNF	0194 - 458 21 - X - 342
	10 - 50	± 3.0		1/4" BSP	0194 - 459 03 - X - 009
				M 10x1 con.	0194 - 459 01 - X - 007
				M 12x1.5 cyl.	0194 - 459 02 - X - 008
				1/4" NPT	0194 - 459 09 - X - 311
				1/8" NPT	0194 - 459 04 - X - 320
7/16-20 UNF				0194 - 459 20 - X - 305	
			9/16-18 UNF	0194 - 459 21 - X - 306	
10 - 100	± 3.0 - 5.0		1/4" BSP	0194 - 461 03 - X - 012	
			M 10x1 con.	0194 - 461 01 - X - 010	
			M 12x1.5 cyl.	0194 - 461 02 - X - 011	
			1/4" NPT	0194 - 461 09 - X - 312	
			1/8" NPT	0194 - 461 04 - X - 321	
			7/16-20 UNF	0194 - 461 20 - X - 307	
			9/16-18 UNF	0194 - 461 21 - X - 308	

### Seal material – Application areas

NBR	Hydraulic/machine oil, air, nitrogen, etc.	1
EPDM	Brake fluid, hydrogen, oxygen, acetylene, etc.	2
FKM	Hydraulic fluids (HFA, HFB, HFD), petrol/gasoline, etc.	3
FFKM	Hot water, chemical acids, diluted alkalis, ketones, esters, alcohols	6
HNBR <sup>2)</sup>	Hydraulic/machine oil, ester-based bio-oils	9

Refer to page 33 for the temperature range and application thresholds of sealing materials.



Article number: 0194 - XXX XX - X - XXX



<sup>1)</sup> Static value. Dynamic value is 30-50 % lower. Values pertain to the hydraulic/pneumatic part of the pressure switch.  
<sup>2)</sup> HNBR diaphragm not available for pressure ranges 0.3 - 1.5 bar.

# 0195

Piston pressure switches up to 24 V with gold contacts

- Made of zinc-plated steel (CrVI-free)
- Socket device similar to DIN EN 175301 (DIN 43650)
- Changeover with gold contacts
- Overpressure safety up to 10,150 psi (700 bar)<sup>1)</sup>
- Hysteresis adjustable at factory

p <sub>max</sub> in bar	Adjustment range in bar	Tolerance at room temperature in bar	Male thread	Article number
----------------------------	----------------------------	---	-------------	----------------

## 0195 Piston pressure switches

10,152 psi <sup>1) 2)</sup> (700 bar)	50 - 200	± 5.0	1/4 BSP	0195 - 460 03 - X - 003
			M 10x1 con.	0195 - 460 01 - X - 001
			M 12x1.5 cyl.	0195 - 460 02 - X - 002
			1/4 NPT	0195 - 460 09 - X - 303
			7/16-20 UNF	0195 - 460 20 - X - 301
			9/16-18 UNF	0195 - 460 21 - X - 302

### Seal material – Application areas

NBR	Hydraulic/machine oil, air, nitrogen, etc.	1
EPDM	Brake fluid, hydrogen, oxygen, acetylene, etc.	2
FKM	Hydraulic fluids (HFA, HFB, HFD), petrol/gasoline, etc.	3
HNBR	Hydraulic/machine oil, ester-based bio-oils	9

Refer to page 33 for the temperature range and application thresholds of sealing materials.

Article number: 0195 - 460 XX - X - XXX

# M.2

hex 27 integrated



Socket device  
included in the delivery

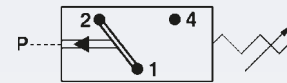

<sup>1)</sup> Static value. Dynamic value is 30-50 % lower. Values pertain to the hydraulic/pneumatic part of the pressure switch.

<sup>2)</sup> Excluding the thread sizes G 1/8, R 1/8, NPT 1/8 and M 10x1 cylindrical/conical.

# M.3

hex 24

## Pressure switches hex 24

NC or NO, maximum voltage 42 V



- Most cost-effective solution for mechanical pressure monitoring
- Stable switching point even after long use and high load
- Switching point can be adjusted when fitted on site<sup>1)</sup>
- High pressure resistance, compact, small switches, available as normally closed (NC) or normally open (NO)
- For solutions with integrated connectors, please refer to chapter M.1, starting at page 22
- For customized and ready-wired pressure switches, please refer to chapter M.5

<sup>1)</sup> Pressure switches can also be supplied preset at factory.

Our preset switches are sealed with lacquer paint, set points are embossed on the housing.

# Pressure switches hex 24

## Technical data

# M.3

## hex 24

Rated working voltage:	10 ... 42 VAC/DC	
Rated current range (resistive load, DC12 / AC12):	10 mA ... 4 A	
Switching power DC12 / AC12:	100 W / 100 VA	
Temperature resistance of sealing materials:	NBR (BunaN)	-40 °F ... +212 °F (-40 °C ... +100 °C)
	NBR (in piston pressure switch)	-22 °F ... +212 °F (-30 °C ... +100 °C)
	EPDM	-22 °F ... +248 °F (-30 °C ... +120 °C)
	EPDM-W270, diaphragm	-4 °F ... +212 °F (-20 °C ... +100 °C)
	FKM (Viton®) (in diaphragm pressure switch)	+23 °F ... +248 °F (-5 °C ... +120 °C)
	FKM (Viton®) (in piston pressure switch)	+5 °F ... +248 °F (-15 °C ... +120 °C)
	FFKM	-4 °F ... +248 °F (-20 °C ... +120 °C)
	Silicone, diaphragm	-40 °F ... +248 °F (-40 °C ... +120 °C)
HNBR	-22 °F ... +248 °F (-30 °C ... +120 °C)	
Burst pressure (diaphragm pressure switch):	5,800 psi (400 bar)	
Burst pressure (piston pressure switch):	10,150 psi (700 bar) (for threads M10, G 1/8, R 1/8 and NPT 1/8 up to max. 600 bar)	
Switching frequency:	200 / min.	
Mechanical life expectancy:	1,000,000 cycles (for diaphragm pressure switches, life expectancy value only applies for switching pressures to max. 725 psi / 50 bar)	
Pressure rise rate:	≤ 14.5 psi/ms (1 bar/ms)	
Differential:	Average value 5 – 30 % depending on type, not adjustable	
Vibration resistance	10 g; 5 – 200 Hz sine wave; DIN EN 60068-2-6	
Shock resistance:	294 m/s <sup>2</sup> ; 14 ms half sine wave; DIN EN 60068-2-27	
Protection class:	IP65 with socket device, terminals IP00	
Weight:	approx. 3.17 oz (90 g)	

Type:		0163	0164	0166	0167	0168	0169
Material:	Zinc-plated steel (CrVI-free)	●		●		●	●
	Stainless steel		●				
	Brass				●		
Overpressure safety up to:	35 bar				●		
	300 bar			●		●	
	600 bar	●	●				●



# 0163

Diaphragm pressure switches up to 42 V with spade terminal

- Made of zinc-plated steel (CrVI-free)
- Spade terminal
- Overpressure safety up to 8,700 psi (600 bar)<sup>1)</sup>, Burst pressure safety up to 10,153 psi (700 bar)<sup>1)</sup>

Adjustment range tolerance at room temperature	Male thread	Order number NO → :	Order number NC → :
---	----------------	------------------------	------------------------

## 0163 Diaphragm pressure switches with spade terminal

1.45 - 14.5 ± 2.90 psi (0.1 - 1 ± 0.2 bar)	M 10x1 taper	0163 - 403 01 - X - 009	0163 - 404 01 - X - 013
	M 12x1.5 cyl.	0163 - 403 02 - X - 010	0163 - 404 02 - X - 014
	1/4" BSPP	0163 - 403 03 - X - 011	0163 - 404 03 - X - 015
	1/8" BSPP	0163 - 403 28 - X - 603	0163 - 403 28 - X - 604
	1/4" NPT	0163 - 403 09 - X - 345	0163 - 404 09 - X - 346
	1/8" NPT	0163 - 403 04 - X - 012	0163 - 404 04 - X - 016
	7/16-20 UNF	0163 - 403 20 - X - 305	0163 - 404 20 - X - 307
	9/16-20 UNF	0163 - 403 21 - X - 306	0163 - 404 21 - X - 308
7.25 - 43.5 ± 4.35 psi (0.5 - 3 ± 0.3 bar)	M 10x1 taper	0163 - 423 01 - X - 070	0163 - 424 01 - X - 070
	M 12x1.5 cyl.	0163 - 423 02 - X - 070	0163 - 424 02 - X - 070
	1/4" BSPP	0163 - 423 03 - X - 070	0163 - 424 03 - X - 070
	1/8" BSPP	0163 - 423 28 - X - 070	0163 - 424 28 - X - 070
	1/4" NPT	0163 - 423 09 - X - 070	0163 - 424 09 - X - 070
	1/8" NPT	0163 - 423 04 - X - 070	0163 - 424 04 - X - 070
	7/16-20 UNF	0163 - 423 20 - X - 070	0163 - 424 20 - X - 070
	9/16-20 UNF	0163 - 423 21 - X - 070	0163 - 424 21 - X - 070
14.5 - 145 ± 7.25 psi (1 - 10 ± 0.5 bar)	M 10x1 taper	0163 - 407 01 - X - 025	0163 - 408 01 - X - 029
	M 12x1.5 cyl.	0163 - 407 02 - X - 026	0163 - 408 02 - X - 030
	1/4" BSPP	0163 - 407 03 - X - 027	0163 - 408 03 - X - 031
	1/8" BSPP	0163 - 407 28 - X - 607	0163 - 408 28 - X - 608
	1/4" NPT	0163 - 407 09 - X - 349	0163 - 408 09 - X - 350
	1/8" NPT	0163 - 407 04 - X - 028	0163 - 408 04 - X - 032
	7/16-20 UNF	0163 - 407 20 - X - 313	0163 - 408 20 - X - 315
	9/16-20 UNF	0163 - 407 21 - X - 314	0163 - 408 21 - X - 316
145 - 290 ± 14.50 psi (10 - 20 ± 1.0 bar)	M 10x1 taper	0163 - 411 01 - X - 041	0163 - 412 01 - X - 045
	M 12x1.5 cyl.	0163 - 411 02 - X - 042	0163 - 412 02 - X - 046
	1/4" BSPP	0163 - 411 03 - X - 043	0163 - 412 03 - X - 047
	1/8" BSPP	0163 - 411 03 - X - 043	0163 - 412 03 - X - 047
	1/4" NPT	0163 - 411 09 - X - 353	0163 - 412 09 - X - 354
	1/8" NPT	0163 - 411 28 - X - 611	0163 - 412 28 - X - 612
	7/16-20 UNF	0163 - 411 20 - X - 321	0163 - 412 20 - X - 323
	9/16-20 UNF	0163 - 411 21 - X - 322	0163 - 412 21 - X - 324
290 - 725 ± 29.0 psi (20 - 50 ± 2.0 bar)	M 10x1 taper	0163 - 415 01 - X - 057	0163 - 416 01 - X - 061
	M 12x1.5 cyl.	0163 - 415 02 - X - 058	0163 - 416 02 - X - 062
	1/4" BSPP	0163 - 415 03 - X - 059	0163 - 416 03 - X - 063
	1/8" BSPP	0163 - 415 28 - X - 615	0163 - 416 28 - X - 616
	1/4" NPT	0163 - 415 09 - X - 357	0163 - 416 09 - X - 358
	1/8" NPT	0163 - 415 04 - X - 060	0163 - 416 04 - X - 064
	7/16-20 UNF	0163 - 415 20 - X - 329	0163 - 416 20 - X - 331
	9/16-20 UNF	0163 - 415 21 - X - 330	0163 - 416 21 - X - 332

### Seal material – Application areas

NBR (BunaN)	Hydraulic/machine oil, heating oil, air, nitrogen, etc.	1
EPDM	Brake fluid, hydrogen, oxygen, acetylene, etc.	2
FKM (Viton®)	Hydraulic fluids (HFA, HFB, HFD), petrol/gasoline, etc.	3
FFKM	Hot water, chemical acids, diluted alkalis, ketones, esters, alcohols	6
HNBR	Hydraulic/machine oil, ester-based bio-oils	9

Your order number:

0163 - XXX XX - X - XXX

# M.3

hex 24



<sup>1)</sup> Static value. Dynamic value is 30-50 % lower. Values pertain to the hydraulic/pneumatic part of the pressure switch.

# M.3

hex 24



## 0163

Diaphragm pressure switches up to 42 V with M3 screw terminal

- Made of zinc-plated steel (CrVI-free)
- M3 screw terminal
- Overpressure safety up to 8,700 psi (600 bar) <sup>1)</sup>

Adjustment range tolerance at room temperature	Male thread	Order number NO →  :	Order number NC →  :
---	----------------	-------------------------	-------------------------

### 0163 Diaphragm pressure switches with M3 screw terminal

1.45 - 14.5 ± 2.90 psi (0.1 - 1 ± 0.2 bar)	M 10x1 taper	0163 - 401 01 - X - 001	0163 - 402 01 - X - 005
	M 12x1.5 cyl.	0163 - 401 02 - X - 002	0163 - 402 02 - X - 006
	1/4" BSPP	0163 - 401 03 - X - 003	0163 - 402 03 - X - 007
	1/8" BSPP	0163 - 401 28 - X - 601	0163 - 402 28 - X - 602
	1/4" NPT	0163 - 401 09 - X - 343	0163 - 402 09 - X - 344
	1/8" NPT	0163 - 401 04 - X - 004	0163 - 402 04 - X - 008
	7/16-20 UNF	0163 - 401 20 - X - 301	0163 - 402 20 - X - 303
9/16-20 UNF	0163 - 401 21 - X - 302	0163 - 402 21 - X - 304	
7.25 - 43.5 ± 4.35 psi (0.5 - 3 ± 0.3 bar)	M 10x1 taper	0163 - 421 01 - X - 070	0163 - 422 01 - X - 070
	M 12x1.5 cyl.	0163 - 421 02 - X - 070	0163 - 422 02 - X - 070
	1/4" BSPP	0163 - 421 03 - X - 070	0163 - 422 03 - X - 070
	1/8" BSPP	0163 - 421 28 - X - 070	0163 - 422 28 - X - 070
	1/4" NPT	0163 - 421 09 - X - 070	0163 - 422 09 - X - 070
	1/8" NPT	0163 - 421 04 - X - 070	0163 - 422 04 - X - 070
	7/16-20 UNF	0163 - 421 20 - X - 070	0163 - 422 20 - X - 070
9/16-20 UNF	0163 - 421 21 - X - 070	0163 - 422 21 - X - 070	
14.5 - 145 ± 7.25 psi (1 - 10 ± 0.5 bar)	M 10x1 taper	0163 - 405 01 - X - 017	0163 - 406 01 - X - 021
	M 12x1.5 cyl.	0163 - 405 02 - X - 018	0163 - 406 02 - X - 022
	1/4" BSPP	0163 - 405 03 - X - 019	0163 - 406 03 - X - 023
	1/8" BSPP	0163 - 405 28 - X - 605	0163 - 406 28 - X - 606
	1/4" NPT	0163 - 405 09 - X - 347	0163 - 406 09 - X - 348
	1/8" NPT	0163 - 405 04 - X - 020	0163 - 406 04 - X - 024
	7/16-20 UNF	0163 - 405 20 - X - 309	0163 - 406 20 - X - 311
9/16-20 UNF	0163 - 405 21 - X - 310	0163 - 406 21 - X - 312	
145 - 290 ± 14.50 psi (10 - 20 ± 1.0 bar)	M 10x1 taper	0163 - 409 01 - X - 033	0163 - 410 01 - X - 037
	M 12x1.5 cyl.	0163 - 409 02 - X - 034	0163 - 410 02 - X - 038
	1/4" BSPP	0163 - 409 03 - X - 035	0163 - 410 03 - X - 039
	1/8" BSPP	0163 - 409 28 - X - 609	0163 - 410 28 - X - 610
	1/4" NPT	0163 - 409 09 - X - 351	0163 - 410 09 - X - 352
	1/8" NPT	0163 - 409 04 - X - 036	0163 - 410 04 - X - 040
	7/16-20 UNF	0163 - 409 20 - X - 317	0163 - 410 20 - X - 319
9/16-20 UNF	0163 - 409 21 - X - 318	0163 - 410 21 - X - 320	
290 - 725 ± 29.0 psi (20 - 50 ± 2.0 bar)	M 10x1 taper	0163 - 413 01 - X - 049	0163 - 414 01 - X - 053
	M 12x1.5 cyl.	0163 - 413 02 - X - 050	0163 - 414 02 - X - 054
	1/4" BSPP	0163 - 413 03 - X - 051	0163 - 414 03 - X - 055
	1/8" BSPP	0163 - 413 28 - X - 051	0163 - 414 28 - X - 055
	1/4" NPT	0163 - 413 09 - X - 355	0163 - 414 09 - X - 356
	1/8" NPT	0163 - 413 04 - X - 052	0163 - 414 04 - X - 056
	7/16-20 UNF	0163 - 413 20 - X - 325	0163 - 414 20 - X - 327
9/16-20 UNF	0163 - 413 21 - X - 326	0163 - 414 21 - X - 328	

### Seal material – Application areas

NBR (BunaN)	Hydraulic/machine oil, heating oil, air, nitrogen, etc.	1
EPDM	Brake fluid, hydrogen, oxygen, acetylene, etc.	2
FKM (Viton®)	Hydraulic fluids (HFA, HFB, HFD), petrol/gasoline, etc.	3
FFKM	Hot water, chemical acids, diluted alkalis, ketones, esters, alcohols	6
HNBR	Hydraulic/machine oil, ester-based bio-oils	9

Refer to page 41 for the temperature range and application thresholds of sealing materials.



Your order number:

0163 - XXX XX - X - XXX

<sup>1)</sup> Static value. Dynamic value is 30-50 % lower. Values pertain to the hydraulic/pneumatic part of the pressure switch.

# 0166

## Diaphragm pressure switches up to 42 V with spade terminal

- Made of zinc-plated steel (CrVI-free)
- Spade terminal
- Overpressure safety up to 4,350 psi (300 bar), Burst pressure safety up to 5,800 psi (400 bar) <sup>1)</sup>

Adjustment range tolerance at room temperature	Male thread	Order number NO → :	Order number NC → :
---	----------------	------------------------	------------------------

### 0166 Diaphragm pressure switches with spade terminal

1.45 - 14.5 ± 2.90 psi (0.1 - 1 ± 0.2 bar)	M 10x1 taper	0166 - 403 01 - X - 009	0166 - 404 01 - X - 013
	M 12x1.5 cyl.	0166 - 403 02 - X - 010	0166 - 404 02 - X - 014
	1/4" BSPP	0166 - 403 03 - X - 011	0166 - 404 03 - X - 015
	1/8" BSPP	0166 - 403 28 - X - 603	0166 - 404 28 - X - 604
	1/4" NPT	0166 - 403 09 - X - 345	0166 - 404 09 - X - 346
	1/8" NPT	0166 - 403 04 - X - 012	0166 - 404 04 - X - 016
	7/16-20 UNF	0166 - 403 20 - X - 305	0166 - 404 20 - X - 307
	9/16-18 UNF	0166 - 403 21 - X - 306	0166 - 404 21 - X - 308
7.25 - 43.5 ± 4.35 psi (0.5 - 3 ± 0.3 bar)	M 10x1 taper	0166 - 423 01 - X - 070	0166 - 424 01 - X - 070
	M 12x1.5 cyl.	0166 - 423 02 - X - 070	0166 - 424 02 - X - 070
	1/4" BSPP	0166 - 423 03 - X - 070	0166 - 424 03 - X - 070
	1/8" BSPP	0166 - 423 28 - X - 070	0166 - 424 28 - X - 070
	1/4" NPT	0166 - 423 09 - X - 070	0166 - 424 09 - X - 070
	1/8" NPT	0166 - 423 04 - X - 070	0166 - 424 04 - X - 070
	7/16-20 UNF	0166 - 423 20 - X - 070	0166 - 424 20 - X - 070
	9/16-18 UNF	0166 - 423 21 - X - 070	0166 - 424 21 - X - 070
14.5 - 145 ± 7.25 psi (1 - 10 ± 0.5 bar)	M 10x1 taper	0166 - 407 01 - X - 025	0166 - 408 01 - X - 029
	M 12x1.5 cyl.	0166 - 407 02 - X - 026	0166 - 408 02 - X - 030
	1/4" BSPP	0166 - 407 03 - X - 027	0166 - 408 03 - X - 031
	1/8" BSPP	0166 - 407 28 - X - 607	0166 - 408 28 - X - 608
	1/4" NPT	0166 - 407 09 - X - 349	0166 - 408 09 - X - 350
	1/8" NPT	0166 - 407 04 - X - 028	0166 - 408 04 - X - 032
	7/16-20 UNF	0166 - 407 20 - X - 313	0166 - 408 20 - X - 315
	9/16-18 UNF	0166 - 407 21 - X - 314	0166 - 408 21 - X - 316
145 - 290 ± 14.50 psi (10 - 20 ± 1.0 bar)	M 10x1 taper	0166 - 411 01 - X - 041	0166 - 412 01 - X - 045
	M 12x1.5 cyl.	0166 - 411 02 - X - 042	0166 - 416 02 - X - 046
	1/4" BSPP	0166 - 411 03 - X - 043	0166 - 412 03 - X - 047
	1/4" NPT	0166 - 411 09 - X - 353	0166 - 412 09 - X - 354
	1/8" NPT	0166 - 411 04 - X - 044	0166 - 412 04 - X - 048
	7/16-20 UNF	0166 - 411 20 - X - 321	0166 - 412 20 - X - 323
	9/16-18 UNF	0166 - 411 21 - X - 322	0166 - 412 21 - X - 324
	290 - 725 ± 29.0 psi (20 - 50 ± 2.0 bar)	M 10x1 taper	0166 - 415 01 - X - 057
M 12x1.5 cyl.		0166 - 415 02 - X - 058	0166 - 416 02 - X - 062
1/4" BSPP		0166 - 415 03 - X - 059	0166 - 416 03 - X - 063
1/8" BSPP		0166 - 415 28 - X - 615	0166 - 416 28 - X - 616
1/4" NPT		0166 - 415 09 - X - 357	0166 - 416 09 - X - 358
1/8" NPT		0166 - 415 04 - X - 060	0166 - 416 04 - X - 064
7/16-20 UNF		0166 - 415 20 - X - 329	0166 - 416 20 - X - 331
9/16-18 UNF		0166 - 415 21 - X - 330	0166 - 416 21 - X - 332

NBR (BunaN)	Hydraulic/machine oil, heating oil, air, nitrogen, etc.	1
EPDM	Brake fluid, hydrogen, oxygen, acetylene, etc.	2
FKM (Viton®)	Hydraulic fluids (HFA, HFB, HFD), petrol/gasoline, etc.	3
FFKM	Hot water, chemical acids, diluted alkalis, ketones, esters, alcohols	6
HNBR	Hydraulic/machine oil, ester-based bio-oils	9

Your order number:

0166 - XXX XX - X - XXX

# M.3

hex 24



<sup>1)</sup> Static value. Dynamic value is 30-50 % lower. Values pertain to the hydraulic/pneumatic part of the pressure switch.

# M.3

hex 24



## 0166

Diaphragm pressure switches up to 42 V with M3 screw terminal

- Made of zinc-plated steel (CrVI-free)
- M3 screw terminal
- Overpressure safety up to 4,350 psi (300 bar)<sup>1)</sup> Burst pressure safety up to 5,800 psi (400 bar)<sup>1)</sup>

Adjustment range tolerance at room temperature	Male thread	Order number NO →  :	Order number NC → :
---	----------------	-------------------------	------------------------

### 0166 Diaphragm pressure switches with M3 screw terminal

1.45 - 14.5 ± 2.90 psi (0.1 - 1 ± 0.2 bar)	M 10x1 taper	0166 - 401 01 - X - 001	0166 - 402 01 - X - 005
	M 12x1.5 cyl.	0166 - 401 02 - X - 002	0166 - 402 02 - X - 006
	1/4" BSPP	0166 - 401 03 - X - 003	0166 - 402 03 - X - 007
	1/8" BSPP	0166 - 401 28 - X - 601	0166 - 402 28 - X - 602
	1/4" NPT	0166 - 401 09 - X - 343	0166 - 402 09 - X - 344
	1/8" NPT	0166 - 401 04 - X - 004	0166 - 402 04 - X - 008
	7/16-20 UNF	0166 - 401 20 - X - 301	0166 - 402 20 - X - 303
	9/16-18 UNF	0166 - 401 21 - X - 302	0166 - 402 21 - X - 304
7.25 - 43.5 ± 4.35 psi (0.5 - 3 ± 0.3 bar)	M 10x1 taper	0166 - 421 01 - X - 070	0166 - 422 01 - X - 070
	M 12x1.5 cyl.	0166 - 421 02 - X - 070	0166 - 422 02 - X - 070
	1/4" BSPP	0166 - 421 03 - X - 070	0166 - 422 03 - X - 070
	1/8" BSPP	0166 - 421 28 - X - 070	0166 - 422 28 - X - 070
	1/4" NPT	0166 - 421 09 - X - 070	0166 - 422 09 - X - 070
	1/8" NPT	0166 - 421 04 - X - 070	0166 - 422 04 - X - 070
	7/16-20 UNF	0166 - 421 20 - X - 070	0166 - 422 20 - X - 070
	9/16-18 UNF	0166 - 421 21 - X - 070	0166 - 422 21 - X - 070
14.5 - 145 ± 7.25 psi (1 - 10 ± 0.5 bar)	M 10x1 taper	0166 - 405 01 - X - 017	0166 - 406 01 - X - 021
	M 12x1.5 cyl.	0166 - 405 02 - X - 018	0166 - 406 02 - X - 022
	1/4" BSPP	0166 - 405 03 - X - 019	0166 - 406 03 - X - 023
	1/8" BSPP	0166 - 405 28 - X - 605	0166 - 406 28 - X - 606
	1/4" NPT	0166 - 405 09 - X - 347	0166 - 406 09 - X - 348
	1/8" NPT	0166 - 405 04 - X - 020	0166 - 406 04 - X - 024
	7/16-20 UNF	0166 - 405 20 - X - 309	0166 - 406 20 - X - 311
	9/16-18 UNF	0166 - 405 21 - X - 310	0166 - 406 21 - X - 312
145 - 290 ± 14.50 psi (10 - 20 ± 1.0 bar)	M 10x1 taper	0166 - 409 01 - X - 033	0166 - 410 01 - X - 037
	M 12x1.5 cyl.	0166 - 409 02 - X - 034	0166 - 410 02 - X - 038
	1/4" BSPP	0166 - 409 03 - X - 035	0166 - 410 03 - X - 039
	1/8" BSPP	0166 - 409 28 - X - 609	0166 - 410 28 - X - 610
	1/4" NPT	0166 - 409 09 - X - 351	0166 - 410 09 - X - 352
	1/8" NPT	0166 - 409 04 - X - 036	0166 - 410 04 - X - 040
	7/16-20 UNF	0166 - 409 20 - X - 317	0166 - 410 20 - X - 319
	9/16-18 UNF	0166 - 409 21 - X - 318	0166 - 410 21 - X - 320
290 - 725 ± 29.0 psi (20 - 50 ± 2.0 bar)	M 10x1 taper	0166 - 413 01 - X - 049	0166 - 414 01 - X - 053
	M 12x1.5 cyl.	0166 - 413 02 - X - 050	0166 - 414 02 - X - 054
	1/4" BSPP	0166 - 413 03 - X - 051	0166 - 414 03 - X - 055
	1/8" BSPP	0166 - 413 28 - X - 613	0166 - 414 28 - X - 614
	1/4" NPT	0166 - 413 09 - X - 355	0166 - 414 09 - X - 356
	1/8" NPT	0166 - 413 04 - X - 052	0166 - 414 04 - X - 056
	7/16-20 UNF	0166 - 413 20 - X - 325	0166 - 414 20 - X - 327
	9/16-18 UNF	0166 - 413 21 - X - 326	0166 - 414 21 - X - 328

#### Seal material – Application areas

NBR (BunaN)	Hydraulic/machine oil, heating oil, air, nitrogen, etc.	1
EPDM	Brake fluid, hydrogen, oxygen, acetylene, etc.	2
FKM (Viton®)	Hydraulic fluids (HFA, HFB, HFD), petrol/gasoline, etc.	3
FFKM	Hot water, chemical acids, diluted alkalis, ketones, esters, alcohols	6
HNBR	Hydraulic/machine oil, ester-based bio-oils	9

Refer to page 41 for the temperature range and application thresholds of sealing materials.

Article number:

0166 - XXX XX - X - XXX

<sup>1)</sup> Static value. Dynamic value is 30-50 % lower. Values pertain to the hydraulic/pneumatic part of the pressure switch.

# M.3

hex 24



# 0168

Diaphragm pressure switches up to 42 V

- Made of zinc-plated steel (CrVI-free)
- Spade or M3 screw terminal
- Overpressure safety up to 4,351 psi (300 bar)<sup>1)</sup>, Burst pressure safety up to 5,800 psi (400 bar)
- With female thread with compression-type fitting to DIN EN ISO 8434-1 (former DIN 2353)

Adjustment range tolerance at room temperature	Female thread	Order number NO →  :	Order number NC → :
---	------------------	-------------------------	------------------------

### 0168 Diaphragm pressure switches with M3 screw terminal

1.45 – 14.5 ±2.90 psi (0.1 – 1 ±0.2 bar)	M 12x1.5 female DIN 2353	0168 – 401 16 -X - 001	0168 – 402 16 -X - 002
7.25 – 43.5 ±4.35 psi (0.5 – 3 ±0.3 bar)		0168 – 421 16 -X - 070	0168 – 422 16 -X - 070
14.5 – 145 ±7.25 psi (1 – 10 ±0.5 bar)		0168 – 405 16 -X - 005	0168 – 406 16 -X - 006
145 – 290 ±14.5 psi (10 – 20 ±1.0 bar)		0168 – 409 16 -X - 009	0168 – 410 16 -X - 010
290 – 725 ±29.0 psi (20 – 50 ±2.0 bar)		0168 – 413 16 -X - 013	0168 – 414 16 -X - 014

### 0168 Diaphragm pressure switches with spade terminal

1.45 – 14.5 ±2.90 psi (0.1 – 1 ±0.2 bar)	M 12x1.5 female DIN 2353	0168 – 403 16 -X - 003	0168 – 404 16 -X - 004
7.25 – 43.5 ±4.35 psi (0.5 – 3 ±0.3 bar)		0168 – 423 16 -X - 070	0168 – 424 16 -X - 070
14.5 – 145 ±7.25 psi (1 – 10 ±0.5 bar)		0168 – 407 16 -X - 007	0168 – 408 16 -X - 008
145 – 290 ±14.5 psi (10 – 20 ±1.0 bar)		0168 – 411 16 -X - 011	0168 – 412 16 -X - 012
290 – 725 ±29.0 psi (20 – 50 ±2.0 bar)		0168 – 415 16 -X - 015	0168 – 416 16 -X - 016

### Seal material – Application areas

NBR (BunaN)	Hydraulic/machine oil, heating oil, air, nitrogen, etc.	1
EPDM	Brake fluid, hydrogen, oxygen, acetylene, etc.	2
FKM (Viton®)	Hydraulic fluids (HFA, HFB, HFD), petrol/gasoline, etc.	3
FFKM	Hot water, chemical acids, diluted alkalis, ketones, esters, alcohols	6
HNBR	Hydraulic/machine oil, ester-based bio-oils	9

Refer to page 41 for the temperature range and application thresholds of sealing materials.

Your order number: 0168 – XXX XX – X –XXX

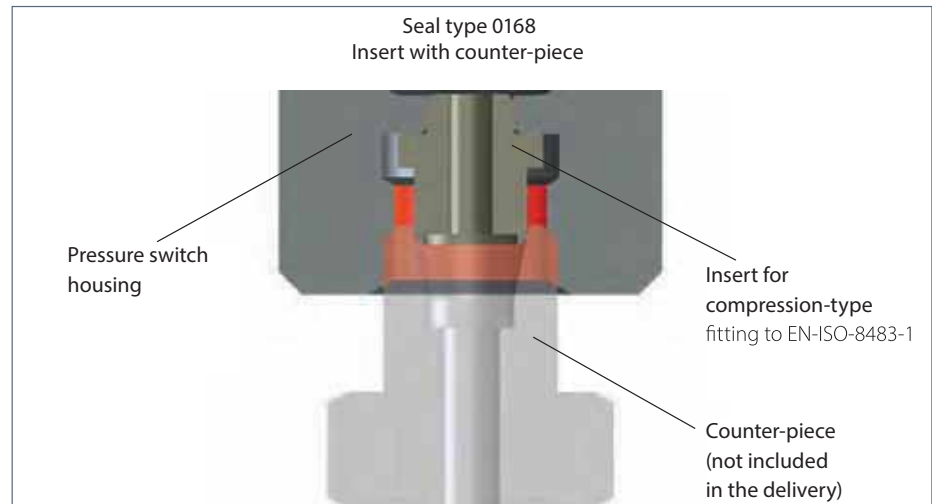

<sup>1)</sup> Static value. Dynamic value is 30-50 % lower. Values pertain to the hydraulic/pneumatic part of the pressure switch.



# 0169

## Piston pressure switches up to 42 V

- Made of zinc-plated steel (CrVI-free)
- Spade or M3 screw terminal
- Overpressure safety up to 8,700 psi (600 bar), Burst pressure safety up to 10,153 psi (700 bar)<sup>1)</sup>

Adjustment range (Tolerance at room temperature)	Male thread	Article number NO →  :	Article number NC → :
---	-------------	---------------------------	--------------------------

### 0169 Piston pressure switches with spade terminal

725 - 2175 ± 72.5 psi (50 - 150 ± 5 bar)	1/4" BSPP	0169 - 419 03 - X - 011	0169 - 420 03 - X - 015
	1/8" BSPP	0169 - 419 28 - X - 603	0169 - 420 28 - X - 604
	M10x1 cyl.	0169 - 419 13 - X - 003	0169 - 420 13 - X - 004
	M10x1 con.	0169 - 419 01 - X - 009	0169 - 420 01 - X - 013
	M12x1.5 cyl.	0169 - 419 02 - X - 010	0169 - 420 02 - X - 014
	NPT1/8	0169 - 419 04 - X - 012	0169 - 420 04 - X - 016

1450 - 2900 ± 72.5 psi (100 - 200 ± 5 bar)	1/4" BSPP	0169 - 493 03 - X - 011	0169 - 494 03 - X - 015
	1/8" BSPP	0169 - 493 28 - X - 603	0169 - 494 28 - X - 604
	M10x1 cyl.	0169 - 493 13 - X - 003	0169 - 494 13 - X - 004
	M10x1 con.	0169 - 493 01 - X - 009	0169 - 494 01 - X - 013
	M12x1.5 cyl.	0169 - 493 02 - X - 010	0169 - 494 02 - X - 014
	NPT1/8	0169 - 493 04 - X - 012	0169 - 494 04 - X - 016
	G 1/4 DIN 3852-2-A	0169 - 491 60 - X - 003	0169 - 492 60 - X - 007
	M12x1.5DIN3852-1-A	0169 - 491 68 - X - 002	0169 - 492 68 - X - 006

### 0169 Piston pressure switches with M3 screw terminal

725 - 2175 ± 72.5 psi (50 - 150 ± 5 bar)	1/4" BSPP	0169 - 417 03 - X - 003	0169 - 418 03 - X - 007
	1/8" BSPP	0169 - 417 28 - X - 601	0169 - 418 28 - X - 602
	M10x1 cyl.	0169 - 417 13 - X - 001	0169 - 418 13 - X - 002
	M10x1 con.	0169 - 417 01 - X - 001	0169 - 418 01 - X - 005
	M12x1.5 cyl.	0169 - 417 02 - X - 002	0169 - 418 02 - X - 006
	NPT1/8	0169 - 417 04 - X - 004	0169 - 418 04 - X - 008

1450 - 2900 ± 72.5 psi (100 - 200 ± 5 bar)	1/4" BSPP	0169 - 491 03 - X - 003	0169 - 492 03 - X - 007
	1/8" BSPP	0169 - 491 28 - X - 601	0169 - 492 28 - X - 602
	M10x1 cyl.	0169 - 491 13 - X - 001	0169 - 492 13 - X - 002
	M10x1 con.	0169 - 491 01 - X - 001	0169 - 492 01 - X - 005
	M12x1.5 cyl.	0169 - 491 02 - X - 002	0169 - 492 02 - X - 006
	NPT1/8	0169 - 491 04 - X - 004	0169 - 492 04 - X - 008
	G 1/4 DIN 3852-2-A	0169 - 491 60 - X - 003	0169 - 492 60 - X - 007
	M12x1.5DIN3852-1-A	0169 - 491 68 - X - 002	0169 - 492 68 - X - 006

### Seal material – Application areas

NBR	Hydraulic/machine oil, heating oil, air, nitrogen, etc.	1
EPDM	Brake fluid, hydrogen, oxygen, acetylene, etc.	2
FKM	Hydraulic fluids (HFA, HFB, HFD), petrol/gasoline, etc.	3
FFKM	Hot water, chemical acids, diluted alkalis, ketones, esters, alcohols	6
HNBR	Hydraulic/machine oil, ester-based bio-oils	9

Refer to page 41 for the temperature range and application thresholds of sealing materials.

Article number: 0169 - XXX XX - X - XXX

# M.3

hex 24



<sup>1)</sup> Static value. Dynamic value is 30-50 % lower. Values pertain to the hydraulic/pneumatic part of the pressure switch.

<sup>2)</sup> Further thread types are available from a minimum order quantity of 500 pieces.

# 0164

Diaphragm pressure switches up to 42 V with stainless steel housing

- Stainless steel housing (AISI 303 / 1.4305)
- Spade or M3 screw terminal
- Overpressure safety up to 8,700 psi (600 bar)<sup>1)</sup> Burst pressure safety up to 10,153 psi (700 bar)<sup>1)</sup> (EPDM-W270 and silicone diaphragm up to 500 psi (35 bar))<sup>2)</sup>

Adjustment range tolerance at room temperature	Male thread	Order number NO →  :	Order number NC → :
---	----------------	-------------------------	------------------------

## 0164 Diaphragm pressure switches with spade terminal

1.45 - 14.5 ± 2.90 psi (0.1 - 1 ± 0.2 bar)	1/4" BSPP-E	0164 - 403 41 - X - 003	0164 - 404 41 - X - 004
	1/8" BSPT	0164 - 403 12 - X - 003	0164 - 404 12 - X - 004
	1/4" BSPT	0164 - 403 46 - X - 003	0164 - 404 46 - X - 004
	1/8" NPT	0164 - 403 04 - X - 003	0164 - 404 04 - X - 004
7.25 - 43.5 ± 4.35 psi (0.5 - 3 ± 0.3 bar)	1/4" BSPP-E	0164 - 423 41 - X - 070	0164 - 424 41 - X - 070
	1/8" BSPT	0164 - 423 12 - X - 070	0164 - 424 12 - X - 070
	1/4" BSPT	0164 - 423 46 - X - 070	0164 - 424 46 - X - 070
	1/8" NPT	0164 - 423 04 - X - 070	0164 - 424 04 - X - 070
14.5 - 145 ± 7.25 psi (1 - 10 ± 0.5 bar)	1/4" BSPP-E	0164 - 407 41 - X - 007	0164 - 408 41 - X - 008
	1/8" BSPT	0164 - 407 12 - X - 007	0164 - 408 12 - X - 008
	1/4" BSPT	0164 - 407 46 - X - 007	0164 - 408 46 - X - 008
	1/8" NPT	0164 - 407 04 - X - 007	0164 - 408 04 - X - 008
145 - 290 ± 14.5 psi (10 - 20 ± 1 bar)	1/4" BSPP-E	0164 - 411 41 - X - 011	0164 - 412 41 - X - 012
	1/8" BSPT	0164 - 411 12 - X - 011	0164 - 412 12 - X - 012
	1/4" BSPT	0164 - 411 46 - X - 011	0164 - 412 46 - X - 012
	1/8" NPT	0164 - 411 04 - X - 011	0164 - 412 04 - X - 012
290 - 725 ± 29.0 psi (20 - 50 ± 2 bar)	1/4" BSPP-E	0164 - 415 41 - X - 015	0164 - 416 41 - X - 016
	1/8" BSPT	0164 - 415 12 - X - 015	0164 - 416 12 - X - 016
	1/4" BSPT	0164 - 415 46 - X - 015	0164 - 416 46 - X - 016
	1/8" NPT	0164 - 415 04 - X - 015	0164 - 416 04 - X - 016

## Seal material – Application areas

NBR (BunaN)	Hydraulic/machine oil, heating oil, air, nitrogen, etc.	1
EPDM	Water, Brake fluid, hydrogen, oxygen, acetylene, etc.	2
EPDM-W270	Drinking water (p <sub>max</sub> ≤ 500 psi / 35 bar)	5
FKM (Viton®)	Hydraulic fluids (HFA, HFB, HFD), petrol/gasoline, etc.	3
FFKM	Hot water, chemical acids, diluted alkalis, ketones, esters, alcohols	6
Silicone	Water, food products, air, etc. (p <sub>max</sub> ≤ 500 psi / 35 bar)	8
HNBR	Hydraulic/machine oil, ester-based bio-oils	9

Your order number: 0164 - XXX XX - X - XXX

# M.3

hex 24



<sup>1)</sup> Static value. Dynamic value is 30-50 % lower. Values pertain to the hydraulic/pneumatic part of the pressure switch.

<sup>2)</sup> Overpressure safety of pressure switch up to 600 bar. Functional reliability only up to 35 bar with diaphragm materials EPDM-TW and silicone.

<sup>3)</sup> The G1/4-E thread has an EPDM sealing ring if the silicone membrane is selected.

# 0164

Diaphragm pressure switches up to 42 V with stainless steel housing

- Stainless steel housing (1.4305 / AISI 303)
- M3 screw terminal
- Overpressure safety up to 8,700 psi (600 bar)<sup>1)</sup>  
EPDM-TW and silicone diaphragm up to max. 35 bar<sup>2)</sup>

Adjustment range (Tolerance at room temperature)	Male thread	Article number NO → :	Article number NC → :
---	-------------	--------------------------	--------------------------

## 0164 Diaphragm pressure switches with screw terminal M3

1.45 - 14.5 ±2.90 psi 0.1 - 1 (± 0.2) bar	1/4 BSPP-E	0164 - 401 41 - X - 001	0164 - 402 41 - X - 002
	1/8" BSPT	0164 - 401 12 - X - 001	0164 - 402 12 - X - 002
	1/4" BSPT	0164 - 401 46 - X - 001	0164 - 402 46 - X - 002
	1/8" NPT	0164 - 401 04 - X - 001	0164 - 402 04 - X - 002
7.25 - 43.5 ±4.35 psi 0.5 - 3 (± 0.3) bar	1/4 BSPP-E	0164 - 421 41 - X - 070	0164 - 422 41 - X - 070
	1/8" BSPT	0164 - 421 12 - X - 070	0164 - 422 12 - X - 070
	1/4" BSPT	0164 - 421 46 - X - 070	0164 - 422 46 - X - 070
	1/8" NPT	0164 - 421 04 - X - 070	0164 - 422 04 - X - 070
14.5 - 145 ±7.25 psi 1 - 10 (± 0.5) bar	1/4 BSPP-E	0164 - 405 41 - X - 005	0164 - 406 41 - X - 006
	1/8" BSPT	0164 - 405 12 - X - 005	0164 - 406 12 - X - 006
	1/4" BSPT	0164 - 405 46 - X - 005	0164 - 406 46 - X - 006
	1/8" NPT	0164 - 405 04 - X - 005	0164 - 406 04 - X - 006
145 - 290 ±14.5 psi 10 - 20 (± 1) bar	1/4 BSPP-E	0164 - 409 41 - X - 009	0164 - 410 41 - X - 010
	1/8" BSPT	0164 - 409 12 - X - 009	0164 - 410 12 - X - 010
	1/4" BSPT	0164 - 409 46 - X - 009	0164 - 410 46 - X - 010
	1/8" NPT	0164 - 409 04 - X - 009	0164 - 410 04 - X - 010
290 - 725 ±29.0 psi 20 - 50 (± 2) bar	1/4 BSPP-E	0164 - 413 41 - X - 013	0164 - 414 41 - X - 014
	1/8" BSPT	0164 - 413 12 - X - 013	0164 - 414 12 - X - 014
	1/4" BSPT	0164 - 413 46 - X - 013	0164 - 414 46 - X - 014
	1/8" NPT	0164 - 413 04 - X - 013	0164 - 414 04 - X - 014



### Seal material – Application areas

NBR	Hydraulic/machine oil, air, nitrogen, etc.	1
EPDM	Water, Brakefluid, hydrogen, oxygen, acetylene, etc.	2
EPDM-TW <sup>2)</sup>	Drinking water ( $p_{max} \leq 35$ bar)	5
FKM	Hydraulic fluids (HFA, HFB, HFD), petrol/gasoline, etc.	3
FFKM	Hot water, chemical acids, diluted alkalis, ketones, esters, alcohols	6
Silicone <sup>2)3)</sup>	Water, food products, air, etc. ( $p_{max} \leq 35$ bar)	8
HNBR	Hydraulic/machine oil, ester-based bio-oils	9

Refer to page 41 for the temperature range and application thresholds of sealing materials.

Article number: 0164 - XXX XX - X - XXX

<sup>1)</sup> Static value. Dynamic value is 30-50 % lower. Values pertain to the hydraulic/pneumatic part of the pressure switch.

<sup>2)</sup> Functional safety and reliability only up to max. 35 bar with EPDM-TW and silicone diaphragm.

<sup>3)</sup> The G 1/4-E thread has an EPDM sealing ring if the silicone membrane is selected.

# 0167

Diaphragm pressure switches up to 42 V with brass housing

- Brass housing
- Spade terminal
- Overpressure safety up to 500 psi (35 bar)<sup>1)</sup>

Adjustment range tolerance at room temperature	Male thread	Order number NO → :	Order number NC → :
---	----------------	------------------------	------------------------

## 0167 Diaphragm pressure switches with spade terminal

1.45 - 14.5 ± 2.9 psi (0.1 - 1 ± 0.2 bar)	M 10x1 taper	0167 - 403 01 - X - 007	0167 - 404 01 - X - 010
	1/8" BSPT	0167 - 403 12 - X - 008	0167 - 404 12 - X - 011
	1/2" BSPT	0167 - 403 07 - X - 009	0167 - 404 07 - X - 012
	1/4" BSPP	0167 - 403 03 - X - 039	0167 - 404 03 - X - 040
	1/8" BSPP	0167 - 403 28 - X - 003	0167 - 404 28 - X - 004
	1/8" NPT	0167 - 403 04 - X - 012	0167 - 404 04 - X - 016
7.25 - 43.5 ± 4.35 psi (0.5 - 3 ± 0.3 bar)	M 10x1 taper	0167 - 423 01 - X - 070	0167 - 424 01 - X - 070
	1/8" BSPT	0167 - 423 12 - X - 070	0167 - 424 12 - X - 070
	1/2" BSPT	0167 - 423 07 - X - 070	0167 - 424 07 - X - 070
	1/4" BSPP	0167 - 423 03 - X - 070	0167 - 424 03 - X - 070
	1/8" BSPP	0167 - 423 28 - X - 070	0167 - 424 28 - X - 070
	1/8" NPT	0167 - 423 04 - X - 070	0167 - 424 04 - X - 070
14.5 - 145 ± 7.25 psi (1 - 10 ± 0.5 bar)	M 10x1 taper	0167 - 407 01 - X - 019	0167 - 408 01 - X - 022
	1/8" BSPT	0167 - 407 12 - X - 020	0167 - 408 12 - X - 023
	1/2" BSPT	0167 - 407 07 - X - 021	0167 - 408 07 - X - 024
	1/4" BSPP	0167 - 407 03 - X - 043	0167 - 408 03 - X - 044
	1/8" BSPP	0167 - 407 28 - X - 007	0167 - 408 28 - X - 008
	1/8" NPT	0167 - 407 04 - X - 028	0167 - 408 04 - X - 032
145 - 290 ± 14.5 psi (10 - 20 ± 1 bar)	M 10x1 taper	0167 - 411 01 - X - 031	0167 - 412 01 - X - 034
	1/8" BSPT	0167 - 411 12 - X - 032	0167 - 412 12 - X - 035
	1/2" BSPT	0167 - 411 07 - X - 033	0167 - 412 07 - X - 036
	1/4" BSPP	0167 - 411 03 - X - 047	0167 - 412 03 - X - 048
	1/8" BSPP	0167 - 411 28 - X - 011	0167 - 412 28 - X - 012
	1/8" NPT	0167 - 411 04 - X - 044	0167 - 412 04 - X - 048

## Seal material – Application areas

NBR (BunaN)	Hydraulic/machine oil, heating oil, air, nitrogen, etc.	1
EPDM	Water, Brake fluid, hydrogen, oxygen, acetylene, etc.	2
EPDM-W270	Drinking water. ≥ 500 psi (p <sub>max</sub> ≥ 35 bar)	5
FKM (Viton®)	Hydraulic fluids (HFA, HFB, HFD), petrol/gasoline, etc.	3
FFKM	Hot water, chemical acids, diluted alkalis, ketones, esters, alcohols	6
Silicone	Water, food products, air, etc. ≥500 psi (p <sub>max</sub> ≥ 35 bar)	8

Refer to page 41 for the temperature range and application thresholds of sealing materials.

Your order number: 0167 - XXX XX - X - XXX

# M.3

hex 24

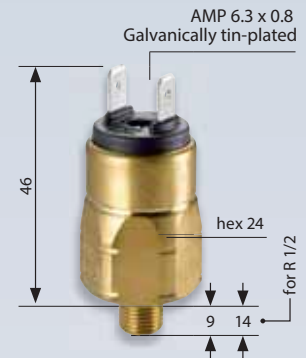

<sup>1)</sup> Static value. Dynamic value is 30-50 % lower. Values pertain to the hydraulic/pneumatic part of the pressure switch.

# M.3

hex 24

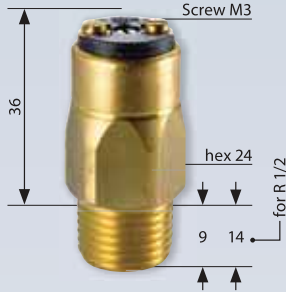

# 0167

Diaphragm pressure switches up to 42 V with brass housing

- Brass housing
- M3 screw terminal
- Overpressure safety up to 500 psi (35 bar)<sup>1)</sup>

Adjustment range tolerance at room temperature	Male thread	Order number NO →  :	Order number NC →  :
---	----------------	-------------------------	-------------------------

### 0167 Diaphragm pressure switches with M3 screw terminal

1.45 - 14.5 ± 2.9 psi (0.1 - 1 ± 0.2 bar)	M 10x1 taper	0167 - 401 01 - X - 001	0167 - 402 01 - X - 004
	1/8" BSPT	0167 - 401 12 - X - 002	0167 - 402 12 - X - 005
	1/2" BSPT	0167 - 401 07 - X - 003	0167 - 402 07 - X - 006
	1/4" BSPP	0167 - 401 03 - X - 037	0167 - 402 03 - X - 038
	1/8" BSPP	0167 - 401 28 - X - 001	0167 - 402 28 - X - 002
	1/8" NPT	0167 - 401 04 - X - 004	0167 - 402 04 - X - 008
7.25 - 43.5 ± 4.35 psi (0.5 - 3 ± 0.3 bar)	M 10x1 taper	0167 - 421 01 - X - 070	0167 - 422 01 - X - 070
	1/8" BSPT	0167 - 421 12 - X - 070	0167 - 422 12 - X - 070
	1/2" BSPT	0167 - 421 07 - X - 070	0167 - 422 07 - X - 070
	1/4" BSPP	0167 - 421 03 - X - 070	0167 - 422 03 - X - 070
	1/8" BSPP	0167 - 421 28 - X - 070	0167 - 422 28 - X - 070
	1/8" NPT	0167 - 421 04 - X - 070	0167 - 422 04 - X - 070
14.5 - 145 ± 7.25 psi (1 - 10 ± 0.5 bar)	M 10x1 taper	0167 - 405 01 - X - 013	0167 - 406 01 - X - 016
	1/8" BSPT	0167 - 405 12 - X - 014	0167 - 406 12 - X - 017
	1/2" BSPT	0167 - 405 07 - X - 015	0167 - 406 07 - X - 018
	1/4" BSPP	0167 - 405 03 - X - 041	0167 - 406 03 - X - 042
	1/8" BSPP	0167 - 405 28 - X - 005	0167 - 406 28 - X - 006
	1/8" NPT	0167 - 405 04 - X - 020	0167 - 406 04 - X - 024
145 - 290 ± 14.5 psi (10 - 20 ± 1 bar)	M 10x1 taper	0167 - 409 01 - X - 025	0167 - 410 01 - X - 028
	1/8" BSPT	0167 - 409 12 - X - 026	0167 - 410 12 - X - 029
	1/2" BSPT	0167 - 409 07 - X - 027	0167 - 410 07 - X - 030
	1/4" BSPP	0167 - 409 03 - X - 045	0167 - 410 03 - X - 046
	1/8" BSPP	0167 - 409 28 - X - 009	0167 - 410 28 - X - 010
	1/8" NPT	0167 - 409 04 - X - 036	0167 - 410 04 - X - 040

### Seal material – Application areas

NBR (BunaN)	Hydraulic/machine oil, heating oil, air, nitrogen, etc.	1
EPDM	Water, Brake fluid, hydrogen, oxygen, acetylene, etc.	2
EPDM-W270	Drinking water. ≥ 500 psi (p <sub>max</sub> ≥ 35 bar)	5
FKM (Viton®)	Hydraulic fluids (HFA, HFB, HFD), petrol/gasoline, etc.	3
FFKM	Hot water, chemical acids, diluted alkalis, ketones, esters, alcohols	6
Silicone	Water, food products, air, etc. ≥500 psi (p <sub>max</sub> ≥ 35 bar)	8



Your order number: **0167 - XXX XX - X - XXX**



1) Static value. Dynamic value is 30-50 % lower. Values pertain to the hydraulic/pneumatic part of the pressure switch.

# Pressure switches hex 27

Changeover with silver or gold contacts



- Switching point can be adjusted when fitted on site<sup>1)</sup>
- Factory adjustable hysteresis (except types 0140 and 0141)
- High overpressure safety and long service life under harsh conditions
- Operating voltage up to 250 V
- Series 0140 / 0141 with protective insulation
- For ready-wired customized versions refer to chapter M.5, starting at page 62
- For pressure switches with integrated connectors refer to chapter M.2, starting at page 32

<sup>1)</sup> Pressure switches can also be supplied preset at factory. Our preset switches are sealed with lacquer paint, set points are embossed on the housing.

# Pressure switches hex 27

## Technical details

M.4

hex 27

Temperature resistance of sealing materials	NBR - diaphragm pressure switches, p <sub>max</sub> = 4,352 / 5,800 psi (300 / 400 bar)	-40 °F ...+212 °F (-40 °C ...+100 °C)
	NBR - diaphragm pressure switch, p <sub>max</sub> = 1,450 psi (100 bar)	-22 °F ...+212 °F (-30 °C ...+100 °C)
	EPDM	-22 °F ...+248 °F (-30 °C ...+120 °C)
	EPDM-TW (in diaphragm pressure switch)	-4 °F ...+212 °F (-20 °C ...+100 °C)
	FKM (in diaphragm pressure switch)	+23 °F ...+248 °F (-5 °C ...+120 °C)
	FKM (in piston pressure switch)	+5 °F ...+248 °F (-15 °C ...+120 °C)
	FFKM	-4 °F ...+248 °F (-20 °C ...+120 °C)
	Silicone (in diaphragm pressure switch)	-40 °F ...+248 °F (-40 °C ...+120 °C)
	HNBR	-22 °F ...+248 °F (-30 °C ...+120 °C)
Burst pressure (diaphragm pressure switch, overpressure resistance 100 bar)	2,900 psi (200 bar)	
Burst pressure (diaphragm pressure switch, overpressure resistance 400 bar)	10,152 psi (700 bar) for threads M10, G 1/8, R 1/8, NPT 1/8 and type 0140 up to max. 600 bar)	
Burst pressure (Piston pressure switch)	14,500 psi (1,000 bar) for threads M10, G 1/8, R 1/8, NPT 1/8 and type 0140 up to max. 600 bar)	
Switching frequency	200/min	
Mechanical life expectancy	1,000,000 cycles (for diaphragm pressure switches, life expectancy value only applies for switching pressures to max. 50 bar)	
Pressure rise rate	≤ 14,500 psi/ms (≤ 1,000 bar/s)	
Hysteresis (only adjustable at factory)	Adjustable average value 10 ... 30 % depending on type Types 0140 and 0141 cannot be adjusted	
Vibration resistance	10 g; 5 ... 200 Hz sine wave; DIN EN 60068-2-6	
Shock resistance	294 m/s <sup>2</sup> ; 14 ms half sine wave; DIN EN 60068-2-6, DIN EN 60068-2-29	
Protection class	IP65 with socket device, terminals IP00	
Weight	approx. 100 g	

### Switching performance and materials overview

Type	0140	0141	0170	0171	0180	0181	0183	0186	0187	0190	0191	0196	0197
5 ... 24 V DC										•	•	•	•
10 ... 42 V AC/DC			•	•									
10 ... 250 V AC/DC	•	•			•	•	•	•	•				
3 ... 50 mA										•	•	•	•
10 mA ... 2 A	•	•											
10 mA ... 4 A			•	•	•	•	•	•	•				
Gold contacts										•	•	•	•
Silver contacts	•	•	•	•	•	•	•	•	•				
Adjustable hysteresis			•	•	•	•	•	•	•	•	•	•	•
Zinc-plated steel (CrVI-free)	•	•	•	•	•	•	•			•	•		
Stainless steel 1.4305								•	•			•	•

# Pressure switches hex 27

## Electrical values

0140 / 0141		
Rated working voltage $U_e$ :	Rated working current $I_e$	Usage category <sup>1)</sup>
250 VAC 50 / 60 Hz	2 A	AC12
24 VDC	2 / 1 A	DC12 / DC13
50 VDC	1 / 0.5 A	DC12 / DC13
75 VDC	0.5 / 0.25 A	DC12 / DC13
125 VDC	0.2 / 0.1 A	DC12 / DC13
250 VDC	0.15 / 0.1 A	DC12 / DC13
Rated insulation voltage $U_i$ :	300 V	
Rated impulse withstand voltage $U_{imp}$ :	4 kV	
Conventional thermal current $I_{the}$ :	5 A	
Switching overvoltage:	< 2.5 kV	
Rated frequency:	DC and 50 / 60 Hz	
Nominal current of short-circuit mechanism:	to 3.5 A	
Rated short-circuit current:	< 350 A	
IP class of protection according to DIN EN 60529:1991+A1:1999:	IP65 with socket device, terminals IP00	
Tightening torque of terminal screws:	< 0.35 Nm	
Connector cross-section:	0.5 - 1.5 mm <sup>2</sup>	

0170 / 0171 / 0180 / 0181 / 0183 / 0186 / 0187 / 0190 / 0191 / 0196 / 0197		
Rated working voltage $U_e$ :	Rated working current $I_e$	Usage category <sup>1)</sup>
250 VAC 50 / 60 Hz	4 A	AC12
250 VAC 50 / 60 Hz	1 A	AC14
24 VDC	4 / 2 A	DC12 / DC13
50 VDC	2 / 1 A	DC12 / DC13
75 VDC	1 / 0.5 A	DC12 / DC13
125 VDC	0.3 / 0.2 A	DC12 / DC13
250 VDC	0.25 / 0.2 A	DC12 / DC13
Rated insulation voltage $U_i$ :	300 V	
Rated impulse withstand voltage $U_{imp}$ :	2.5 kV	
Conventional thermal current $I_{the}$ :	5 A	
Switching overvoltage:	< 2.5 kV	
Rated frequency:	DC and 50 / 60 Hz	
Nominal current of short-circuit mechanism:	to 5 A	
Rated short-circuit current:	< 350 A	
IP class of protection according to DIN EN 60529:1991+A1:1999:	IP65 with socket device, terminals IP00	

# 0140 / 0141

## Diaphragm / piston pressure switches 250 V

- Protection class 2, protective insulation
- Zinc-plated steel (CrVI-free)
- Changeover with silver contacts
- Overpressure safety up to 4,300 psi / 8,700 psi (300 / 600 bar)<sup>1)</sup>
- Includes polyamide cap, protection class IP65

$p_{max}$ in bar	Adjustment range in bar	Tolerance at room temperature in bar	Male thread	Article number
---------------------	----------------------------	---	-------------	----------------

### 0140 Diaphragm pressure switches with screw terminals

$p_{max}$ in bar	Adjustment range in bar	Tolerance at room temperature in bar	1/4" BSPP	0140 - 457 03 - X - 003
			1/8" NPT	0140 - 457 04 - X - 300
4,350 psi (300 bar)	0.435 - 21.75 psi (0.3 - 1.5 bar)	± 2.90 psi (± 0.2 bar)	1/4" NPT	0140 - 457 09 - X - 305
			7/16-20 UNF	0140 - 457 20 - X - 310
			9/16-18 UNF	0140 - 457 21 - X - 315
			1/4" BSPP	0140 - 458 03 - X - 006
4,350 psi (300 bar)	14.5 - 145 psi (1 - 10 bar)	± 7.25 psi (± 0.5 bar)	1/8" NPT	0140 - 458 04 - X - 301
			1/4" NPT	0140 - 458 09 - X - 306
			7/16-20 UNF	0140 - 458 20 - X - 311
			9/16-18 UNF	0140 - 458 21 - X - 316
4,350 psi (300 bar)	145 - 290 psi (10 - 20 bar)	± 14.50 psi (± 1.0 bar)	1/4" BSPP	0140 - 459 03 - X - 009
			1/8" NPT	0140 - 459 04 - X - 302
			1/4" NPT	0140 - 459 09 - X - 307
			7/16-20 UNF	0140 - 459 20 - X - 312
4,350 psi (300 bar)	290 - 725 psi (20 - 50 bar)	± 29 psi (± 2.0 bar)	9/16-18 UNF	0140 - 459 21 - X - 317
			1/4" BSPP	0140 - 461 03 - X - 012
			1/8" NPT	0140 - 461 04 - X - 303
			1/4" NPT	0140 - 461 09 - X - 308
4,350 psi (300 bar)	290 - 725 psi (20 - 50 bar)	± 29 psi (± 2.0 bar)	7/16-20 UNF	0140 - 461 20 - X - 313
			9/16-18 UNF	0140 - 461 21 - X - 318

### 0141 Piston pressure switches with screw terminals

$p_{max}$ in bar	Adjustment range in bar	Tolerance at room temperature in bar	1/4" BSPP	0141 - 460 03 - X - 003
			1/8" NPT	0141 - 460 04 - X - 304
8,700 psi (600 bar)	725 - 2,175 psi (50 - 150 bar)	± 72.5 psi (± 5.0 bar)	1/4" NPT	0141 - 460 09 - X - 309
			7/16-20 UNF	0141 - 460 20 - X - 314
			9/16-18 UNF	0141 - 460 21 - X - 319

### Seal material – Application areas

NBR	Hydraulic/machine oil, heating oil, air, nitrogen, etc.	1
EPDM	Brake fluid, hydrogen, oxygen, acetylene, etc.	2
FKM	Hydraulic fluids (HFA, HFB, HFD), petrol/gasoline, etc.	3
FFKM	Hot water, chemical acids, diluted alkalis, ketones, esters, alcohols	6
HNBR	Hydraulic/machine oil, ester-based bio-oils	9

Refer to page 53 for the temperature range and application thresholds of sealing materials.



Article number: 014X - XXX XX - X - XXX

M.4  
hex 27



<sup>1)</sup> Static value. Dynamic value is 30-50 % lower. Values pertain to the hydraulic/pneumatic part of the pressure switch.

# M.4

hex 27



## 0170 / 0171

Diaphragm / piston pressure switches up to 42 V

- Zinc-plated steel (CrVI-free)
- Snap action with silver contacts
- Overpressure safety up to 1,450 / 5,801 / 10,152 psi (100 / 400 / 700 bar)<sup>1)</sup>
- Differential adjustable at factory

P <sub>max.</sub> in psi (bar)	Adjustment range in psi (bar)	Tolerance in psi (bar) at room temperature	Male thread	Order number
-----------------------------------	----------------------------------	---	-------------	--------------

### 0170 Diaphragm pressure switches with spade terminal

1,450 psi <sup>1)</sup> (100 bar) <sup>1)</sup>	4.35 - 21.75 psi (0.3 - 1.5 bar)	± 2.90 psi (± 0.2 bar)	M 10x1 taper	0170 - 457 01 - X - 001
			M 12x1.5 cyl.	0170 - 457 02 - X - 002
			1/4" BSPP	0170 - 457 03 - X - 003
			1/8" NPT	0170 - 457 04 - X - 318
			1/4" NPT	0170 - 457 09 - X - 314
			7/16-20 UNF	0170 - 457 20 - X - 301
			9/16-18 UNF	0170 - 457 21 - X - 302

	14.5 - 145 psi (1 - 10 bar)	± 7.25 psi (± 0.5 bar)	M 10x1 taper	0170 - 458 01 - X - 040
			M 12x1.5 cyl.	0170 - 458 02 - X - 041
			1/4" BSPP	0170 - 458 03 - X - 042
			1/8" NPT	0170 - 458 04 - X - 343
			1/4" NPT	0170 - 458 09 - X - 340
			7/16-20 UNF	0170 - 458 20 - X - 341
			9/16-18 UNF	0170 - 458 21 - X - 342

5,801 psi <sup>1)</sup> (400 bar) <sup>1)</sup>	145 - 725 psi (10 - 50 bar)	± 43.5 psi (± 3.0 bar)	M 10x1 taper	0170 - 459 01 - X - 007
			M 12x1.5 cyl.	0170 - 459 02 - X - 008
			1/4" BSPP	0170 - 459 03 - X - 009
			1/8" NPT	0170 - 459 04 - X - 320
			1/4" NPT	0170 - 459 09 - X - 316
			7/16-20 UNF	0170 - 459 20 - X - 305
			9/16-18 UNF	0170 - 459 21 - X - 306

	145 - 1,450 psi (10 - 100 bar)	± 43.5 - 72.5 psi (± 3.0 - 5.0 bar)	M 10x1 taper	0170 - 461 01 - X - 010
			M 12x1.5 cyl.	0170 - 461 02 - X - 011
			1/4" BSPP	0170 - 461 03 - X - 012
			1/8" NPT	0170 - 461 04 - X - 321
			1/4" NPT	0170 - 461 09 - X - 317
			7/16-20 UNF	0170 - 461 20 - X - 307
			9/16-18 UNF	0170 - 461 21 - X - 308

### 0171 Piston pressure switches with spade terminal

10,152 psi <sup>1)</sup> (700 bar) <sup>1)</sup>	725 - 2,900 psi (50 - 200 bar)	± 72.5 psi (± 5.0 bar)	M 10x1 taper	0171 - 460 01 - X - 001
			M 12x1.5 cyl.	0171 - 460 02 - X - 002
			1/4" BSPP	0171 - 460 03 - X - 003
			1/8" NPT	0171 - 460 04 - X - 304
			1/4" NPT	0171 - 460 09 - X - 303
			7/16-20 UNF	0171 - 460 20 - X - 301
			9/16-18 UNF	0171 - 460 21 - X - 302

### Seal material – Application areas

NBR (BunaN)	Hydraulic/machine oil, heating oil, air, nitrogen, etc.	1
EPDM	Brake fluid, hydrogen, oxygen, acetylene, etc.	2
FKM (Viton®)	Hydraulic fluids (HFA, HFB, HFD), petrol/gasoline, etc.	3
FFKM	Hot water, chemical acids, diluted alkalis, ketones, esters, alcohols	6
HNBR	Hydraulic/machine oil, ester-based bio-oils	9

Refer to page 53 for the temperature range and application thresholds of sealing materials.



Your order number:

017X - XXX XX - X - XXX



1) Static value. Dynamic value is 30-50% lower. Values pertain to the hydraulic/pneumatic part of the pressure switch.

2) Excluding the thread sizes G 1/8, R 1/8, NPT 1/8 and M 10x1 cylindrical/conical.

3) HNBR diaphragm not available for pressure ranges between 0.3 - 1.5 bar.

# 0180 / 0181

## Diaphragm / piston pressure switches up to 250 V

- Zinc-plated steel (CrVI-free)
- Snap action with silver contacts
- Overpressure safety up to 1,450 / 5,801 / 10,152 psi (100 / 400 / 700 bar)<sup>1)</sup>
- Differential adjustable at factory

p <sub>max.</sub> in psi (bar)	Adjustment range in psi (bar)	Tolerance in psi (bar) at room temperature	Male thread	Order number
-----------------------------------	----------------------------------	---	-------------	--------------

### 0180 Diaphragm pressure switches with spade terminal

p <sub>max.</sub> in psi (bar)	Adjustment range in psi (bar)	Tolerance in psi (bar) at room temperature	Male thread	Order number
			M 10x1 taper	0180 - 457 01 - X - 001
1,450 psi <sup>1)</sup> (100 bar)	4.35 - 21.75 psi (0.3 - 1.5 bar)	± 2.90 psi (± 0.2 bar)	M 12x1.5 cyl.	0180 - 457 02 - X - 002
			1/4" BSPP	0180 - 457 03 - X - 003
			1/8" NPT	0180 - 457 04 - X - 318
			1/4" NPT	0180 - 457 09 - X - 314
			7/16-20 UNF	0180 - 457 20 - X - 301
			9/16-18 UNF	0180 - 457 21 - X - 302
	14.5 - 145 psi (1 - 10 bar)	± 7.25 psi (± 0.5 bar)	M 10x1 taper	0180 - 458 01 - X - 040
			M 12x1.5 cyl.	0180 - 458 02 - X - 041
			1/4" BSPP	0180 - 458 03 - X - 042
			1/8" NPT	0180 - 458 04 - X - 343
			1/4" NPT	0180 - 458 09 - X - 340
			7/16-20 UNF	0180 - 458 20 - X - 341
	145 - 725 psi (10 - 50 bar)	± 43.5 psi (± 3.0 bar)	M 10x1 taper	0180 - 459 01 - X - 007
			M 12x1.5 cyl.	0180 - 459 02 - X - 008
			1/4" BSPP	0180 - 459 03 - X - 009
			1/8" NPT	0180 - 459 04 - X - 320
			1/4" NPT	0180 - 459 09 - X - 311
			7/16-20 UNF	0180 - 459 20 - X - 305
	145 - 1,450 psi (10 - 100 bar)	± 43.5 - 72.5 psi (± 3.0 - 5.0 bar)	M 10x1 taper	0180 - 461 01 - X - 010
			M 12x1.5 cyl.	0180 - 461 02 - X - 011
			1/4" BSPP	0180 - 461 03 - X - 012
			1/8" NPT	0180 - 461 04 - X - 321
			1/4" NPT	0180 - 461 09 - X - 312
			7/16-20 UNF	0180 - 461 20 - X - 307
			9/16-18 UNF	0180 - 461 21 - X - 308

### 0181 Piston pressure switches with spade terminal

p <sub>max.</sub> in psi (bar)	Adjustment range in psi (bar)	Tolerance in psi (bar) at room temperature	Male thread	Order number
			M 10x1 taper	0181 - 460 01 - X - 001
10,152 psi <sup>1)</sup> (700 bar)	725 - 2,900 psi (50 - 200 bar)	± 72.5 psi (± 5.0 bar)	M 12x1.5 cyl.	0181 - 460 02 - X - 002
			1/4" BSPP	0181 - 460 03 - X - 003
			1/8" NPT	0181 - 460 04 - X - 304
			1/4" NPT	0181 - 460 09 - X - 303
			7/16-20 UNF	0181 - 460 20 - X - 301
			9/16-18 UNF	0181 - 460 21 - X - 302

### Seal material – Application areas

NBR (BunaN)	Hydraulic/machine oil, heating oil, air, nitrogen, etc.	1
EPDM	Brake fluid, hydrogen, oxygen, acetylene, etc.	2
FKM(Viton®)	Hydraulic fluids (HFA, HFB, HFD), petrol/gasoline, etc.	3
FFKM	Hot water, chemical acids, diluted alkalis, ketones, esters, alcohols	6
HNBR <sup>2)</sup>	Chemical acids, diluted alkalis, ketones, ester's, alcohols	9

Refer to page 53 for the temperature range and application thresholds of sealing materials. ↓

Your order number: 018X - XXX XX - X - XXX

# M.4

hex 27

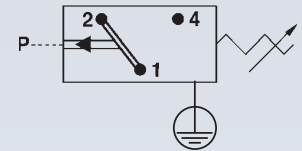

<sup>1)</sup> Static value. Dynamic value is 30-50% lower. Values pertain to the hydraulic/pneumatic part of the pressure switch.

<sup>2)</sup> HNBR diaphragm not available for pressure ranges between 4.35 - 21.75 psi (0.3 - 1.5 bar).

# M.4

hex 27

Thread similar to ISO 6149-3  
(including O-ring for sealing)



# 0183

Piston pressure switches up to 250 V

- Zinc-plated steel (CrVI-free)
- Snap action with silver contacts
- Overpressure safety up to 8,700 psi (600 bar)<sup>1)</sup>, Differential adjustable at factory
- Adjustment range: 1,450 - 5,800 psi (100 – 400 bar)
- Height only 51 mm

P <sub>max.</sub> in psi (bar)	Adjustment range in psi (bar)	Tolerance in psi (bar) at room temperature	Male thread	Order number
-----------------------------------	----------------------------------	---	-------------	--------------

### 0183 Piston pressure switches with spade terminal

8,700 psi <sup>1)</sup> (600 bar) <sup>1)</sup>	1,450 - 4,350 psi (100 - 300 bar)	± 145 psi (±10.0 bar)	M 14x1.5	0183 - 462 45 - X - 051
	2,900 - 5,800 psi (200 - 400 bar)			0183 - 463 45 - X - 061

### Seal material – Application areas

NBR (BunaN)	Hydraulic/machine oil, heating oil, air, nitrogen, etc.	1
EPDM	Brake fluid, hydrogen, oxygen, acetylene, etc.	2
FKM (Viton®)	Hydraulic fluids (HFA, HFB, HFD), petrol/gasoline, etc.	3
HNBR	Hydraulic/machine oil, ester-based bio-oils	9



Your order number: 0183 - 46X 45 - X -XXX

<sup>1)</sup> Static value. Dynamic value is 30-50 % lower. Values pertain to the hydraulic/pneumatic part of the pressure switch.

### Accessory ▶

Not included in the delivery.  
Please order separately.

### Thread adapters

from M 14 x 1.5		
to 1/4 BSPP	to M12 x 1.5	to NPT 1/8
1-1-83-420-006	1-1-83-420-007	1-1-83-420-008

Order number ▶

# 0186 / 0187

Diaphragm / piston pressure switches up to 250 V with stainless steel housing

- Stainless steel housing (AISI 303 / 1.4305)
- Snap action with silver contacts
- Overpressure safety up to 5,801 / 10,152 psi (400 / 700 bar)<sup>1)</sup> (EPDM-W270 and silicone diaphragm up to 500 psi (35 bar)<sup>2)</sup>
- Differential adjustable at factory

P <sub>max.</sub> in psi (bar)	Adjustment range in psi (bar)	Tolerance in psi (bar) at room temperature	Male thread	Order number
-----------------------------------	----------------------------------	---	-------------	--------------

## 0186 Diaphragm pressure switches with spade terminal

1,450 psi (100 bar)	4.3 - 21.7 psi (0.3 - 1.5 bar)	2.9 psi (± 0.2 bar)	1/4 BSPP DIN 3852-2-A	0186 - 446 60 - X - 001
	14.5 - 145 psi (1-10 bar)	7.25 psi (± 0.5 bar)		0186 - 458 60 - X - 050

5,800 psi (400 bar) <sup>1)2)</sup>	7.25 - 72.5 psi (0.5 - 5 bar)	± 4.35 psi (± 0.3 bar)	1/4 BSPP	0186 - 457 03 - X - 003
	14.5 - 145 psi (1 - 10 bar)	± 7.25 psi (± 0.5 bar)		0186 - 458 03 - X - 006
	145 - 725 psi (10 - 50 bar)	± 43.5 psi (± 3.0 bar)		0186 - 459 03 - X - 009
	145 - 1,450 psi (10 - 100 bar)	± 43.5 - 72.5 psi (± 3.0 - 5.0 bar)		0186 - 461 03 - X - 012

## 0187 Piston pressure switches with spade terminal

10,152 psi <sup>1)</sup> (700 bar) <sup>1)</sup>	725 - 2,900 psi (50 - 200 bar)	± 7.25 psi (± 0.5 bar)	1/4 BSPP	0187 - 460 03 - X - 003
8,700 psi (600 bar)			1/8" NPT	0187 - 460 04 - X - 304

## Seal material – Application areas

NBR (BunaN)	Hydraulic/machine oil, heating oil, air, nitrogen, etc.	1
EPDM	Brake fluid, hydrogen, oxygen, acetylene, etc.	2
EPDM-W270	Drinking water (only in diaphragm, p <sub>max</sub> ≤ 500 psi / 35 bar)	5
FKM (Viton®)	Hydraulic fluids (HFA, HFB, HFD), petrol/gasoline, etc.	3
FFKM	Hot water, chemical acids, diluted alkalis, ketones, esters, alcohols	6
Silicone	Water, food products, air, etc(only in diaphragm (p <sub>max</sub> ≤ 500 psi / 35 bar)	8
HNBR	Hydraulic/machine oil, ester-based bio-oils	9

Refer to page 53 for the temperature range and application thresholds of sealing materials.

Your order number: 018X - XXX 03 - X - XXX

# M.4

hex 27

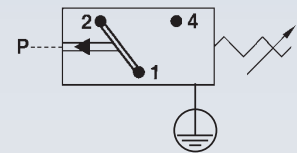

1) Static value. Dynamic value is 30-50 % lower. Values pertain to the hydraulic/pneumatic part of the pressure switch.  
2) Functional safety and reliability only up to max. 35 bar with EPDM-TW and silicone diaphragm.

3) Including the thread sizes 1/8 BSPP, 1/8 BSPT and M 10x1 cylindrical/conical.

# M.4

hex 27

## 0190 / 0191

Diaphragm / piston pressure switches up to 24 V with gold contacts

- Zinc-plated steel (CrVI-free), with spade terminal
- Snap action with gold contacts
- Overpressure safety up to 1,450 / 5,801 / 10,152 psi (100 / 400 / 700 bar)<sup>1)</sup>
- Differential adjustable at factory



P <sub>max.</sub> in psi (bar)	Adjustment range in psi (bar)	Tolerance in psi (bar) at room temperature	Male thread	Order number
-----------------------------------	----------------------------------	---	-------------	--------------

### 0190 Diaphragm pressure switches with spade terminal

1,450 psi <sup>1)</sup> (100 bar) <sup>1)</sup>	4.35 - 21.75 psi (0.3 - 1.5 bar)	± 2.90 psi (± 0.2 bar)	M 10 x1 taper	0190 - 457 01 - X - 001
			M 12x1.5 cyl.	0190 - 457 02 - X - 002
			1/4" BSPP	0190 - 457 03 - X - 003
			1/4" NPT	0190 - 457 09 - X - 314
			1/8" NPT	0190 - 457 04 - X - 318
			7/16-20 UNF	0190 - 457 20 - X - 301
			9/16/18 UNF	0190 - 457 21 - X - 302

14.5 - 145 psi (1 - 10 bar)	± 7.25 psi (± 0.5 bar)	M 10 x1 taper	0190 - 458 01 - X - 040	
		M 12x1.5 cyl.	0190 - 458 01 - X - 041	
		1/4" BSPP	0190 - 458 03 - X - 042	
		1/4" NPT	0190 - 458 09 - X - 340	
		1/8" NPT	0190 - 458 04 - X - 343	
		7/16-20 UNF	0190 - 458 20 - X - 341	
			9/16/18 UNF	0190 - 458 21 - X - 342

5,801 psi <sup>1)</sup> (400 bar) <sup>1)</sup>	145- 725 psi (10 - 50 bar)	± 43.5 psi (± 3.0 bar)	M 10 x1 taper	0190 - 459 01 - X - 007
			M 12x1.5 cyl.	0190 - 459 01 - X - 008
			1/4" BSPP	0190 - 459 03 - X - 009
			1/4" NPT	0190 - 459 09 - X - 316
			1/8" NPT	0190 - 459 04 - X - 320
			7/16-20 UNF	0190 - 459 20 - X - 305
			9/16/18 UNF	0190 - 459 21 - X - 306

145 - 1,450 psi (10 - 100 bar)	± 43.5 - 72.5 psi (± 3.0 - 5.0 bar)	M 10 x1 taper	0190 - 461 01 - X - 010	
		M 12x1.5 cyl.	0190 - 461 02 - X - 011	
		1/4" BSPP	0190 - 461 03 - X - 012	
		1/4" NPT	0190 - 461 09 - X - 317	
		1/8" NPT	0190 - 461 04 - X - 321	
		7/16-20 UNF	0190 - 461 20 - X - 307	
			9/16/18 UNF	0190 - 461 21 - X - 308

### 0191 Piston pressure switches with spade terminal

10,152 psi <sup>1)</sup> (700 bar) <sup>1)</sup>	725 - 2,900 psi (50- 200 bar)	± 72.5 psi (± 5.0 bar)	M 10 x1 taper	0191 - 460 01 - X - 001
			M 12x1.5 cyl.	0191 - 460 02 - X - 002
			1/4" BSPP	0191 - 460 03 - X - 003
			1/4" NPT	0191 - 460 09 - X - 303
			1/8" NPT	0191 - 460 04 - X - 304
			7/16-20 UNF	0191 - 460 20 - X - 301
			9/16/18 UNF	0191 - 460 21 - X - 302

### Seal material – Application areas

NBR (BunaN)	Hydraulic/machine oil, heating oil, air, nitrogen, etc.	1
EPDM	Brake fluid, hydrogen, oxygen, acetylene, etc.	2
FKM (Viton®)	Hydraulic fluids (HFA, HFB, HFD), petrol/gasoline, etc.	3
FFKM	Chemical acids, diluted alkalis, ketones, ester's, alcohols	6
HNBR	Hydraulic/machine oil, ester-based bio-oils	9

Refer to page 53 for the temperature range and application thresholds of sealing materials. ↓

Your order number:

019X - XXX XX - X - XXX

1) Static value. Dynamic value is 30-50 % lower. Values pertain to the hydraulic/pneumatic part of the pressure switch.  
 2) Excluding the thread sizes G 1/8, R 1/8, NPT 1/8 and M 10x1 cylindrical/conical.  
 3) HNBR diaphragm not available for pressure ranges between 0.3 - 1.5 bar.

# 0196 / 0197

Diaphragm / piston pressure switches up to 24 V with stainless steel housing

- Stainless steel housing (AISI 303 / 1.4305)
- Fitted with snap action contact and gold contacts
- Overpressure safety up to 5,801 / 10,152 psi (400 / 700 bar)<sup>1)</sup>  
(EPDM-W270 and silicone diaphragm up to 500 psi / 35 bar)<sup>2)</sup>
- Differential adjustable at factory

P <sub>max.</sub> in psi (bar)	Adjustment range in psi (bar)	Tolerance in psi (bar) at room temperature	Male thread	Order number
-----------------------------------	----------------------------------	---	-------------	--------------

## 0196 Diaphragm pressure switches with spade terminal

1,450 psi (100 bar)	4.3 - 21.7 psi (0.3 - 1.5 bar)	2.9 psi (± 0.2 bar)	1/4 BSPP DIN 3852-2-A	0196 - 446 60 - X - 001
	14.5 - 145 psi (1-10 bar)	7.25 psi (± 0.5 bar)		0196 - 458 60 - X - 050

5,801 psi <sup>1)+2)</sup> (400 bar) <sup>1)+2)</sup>	7.25 - 72.5 psi (0.5 - 5 bar)	± 4.35 psi (± 0.3 bar)	1/4 BSPP	0196 - 457 03 - X - 003
	14.5 - 145 psi (1 - 10 bar)	± 7.25 psi (± 0.5 bar)		0196 - 458 03 - X - 006
	145 - 725 psi (10 - 50 bar)	± 43.5 psi (± 3.0 bar)		0196 - 459 03 - X - 009
	145 - 1,450 psi (10 - 100 bar)	± 43.5 - 72.5 psi (± 3.0 - 5.0 bar)		0196 - 461 03 - X - 012

## 0197 Piston pressure switches with spade terminal

10,152 psi <sup>1)</sup> (700 bar) <sup>1)</sup>	725 - 2,900 psi (50 - 200 bar)	± 7.25 psi (± 0.5 bar)	1/4 BSPP	0197 - 460 03 - X - 003
8,700 psi (600 bar)			1/8" NPT	0197 - 460 04 - X - 304

## Seal material – Application areas

NBR (BunaN)	Hydraulic/machine oil, heating oil, air, nitrogen, etc.	1
EPDM	Water, Brake fluid, hydrogen, oxygen, acetylene, etc.	2
EPDM-TW	Drinking water (only in diaphragm, p <sub>max</sub> ≤ 500 psi / 35 bar)	5
FKM (Viton®)	Hydraulic fluids (HFA, HFB, HFD), petrol/gasoline, etc.	3
FFKM	Hot water, chemical acids, diluted alkalis, ketones, ester's, alcohols	6
Silicone	Water, food products, air, etc (only in diaphragm, p <sub>max</sub> ≤ 500 psi / 35 bar)	8
HNBR	Hydraulic/machine oil, ester-based bio-oils	9

Refer to page 53 for the temperature range and application thresholds of sealing materials.

Your order number: 019X - XXX 03 - X - XXX

- 1) Static value. Dynamic value is 30-50 % lower. Values pertain to the hydraulic/pneumatic part of the pressure switch.
- 2) Functional safety and reliability only up to max. 35 bar with EPDM-TW and silicone diaphragm.
- 3) Including the thread sizes G 1/8, R 1/8 and M 10x1 cylindrical/conical.

# M.4

hex 27



## M.5

hex 24 / 27  
Ready-wired

# hex 24 / hex 27 ready-wired pressure switches

Custom designs



- Ready-wired pressure switches hex 24 and hex 27, available with all commercial plug-in types and individual cable length.
- The technical details of ready-wired pressure switch types correspond to those of the same standard pressure switch types. Different technical details will be agreed with the customer.
- Pressure switches usually have protection class IP65. Our ready-wired pressure switches attain IP67 or IP6K9K. This is a requirement particularly in commercial vehicle construction, mobile hydraulics and similarly demanding applications.
- Ready-wired pressure switches enable plug connectors to be moved in climatically non-critical and low-vibration areas.
- The modular layout also enables the production of lower volumes.
- The switching point for ready-wired pressure switches is factory-set to a fixed value. Exception: The switching point of the 0240/0241 can be adjusted on site even after the sealing process.

# hex 24 / 27

## Custom designs

All hex 24 and hex 27 pressure switches can be individually wired according to customer needs.

### Standard types suitable for ready-wiring

<p>0163 / 0166 0164 0167 0169</p>	<p>0168</p>	<p>0170 / 0171 0180 / 0181 0190 / 0191 0196 / 0197</p>	<p>0140 / 0141</p>
			
<p>Technical details page 41</p>	<p>Technical details page 41</p>	<p>Technical details page 53</p>	<p>Technical details page 53</p>
<p>The switching point is factory preset and cannot be changed subsequently, so please state the switching point when ordering.</p>		<p>The switching point is adjustable even after sealing.</p>	

# M.5

hex 24 / 27  
Ready-wired

Please note our detailed information on

- CE marking
- protection class
- custom applications

For gas applications below 10 bar (145 PSI) we generally recommend venting the housing for encapsulated pressure switches.

### A selection from the wide variety of connectors we can supply

<p>Connector to DIN 72585-A1-4.1</p>	
<p>AMP Junior Timer®</p>	
<p>Cannon connector</p>	
<p>AMP Superseal 1.5°</p>	
<p>Packard connector (Weather Pack® 2-wire)</p>	
<p>Packard connector (Weather Pack® 3-wire)</p>	
<p>Deutsch connector (DT 06 - 2S)</p>	
<p>Deutsch connector (DT 04 - 2P)</p>	
<p>Deutsch connector (DT 04 - 3P)</p>	

# M.5

hex 24 / 27  
Ready-wired

## 0240 / 0241

Diaphragm / piston pressure switches, hex 27

### Technical data

Refer to page 54 for electrical values

Rated working voltage:	max. 42 V / 250 V depending on connection
Rated working current:	max. 2 A
Protection class:	2, protective insulation
Temperature resistance of sealing materials:	NBR (diaphragm pressure switch) -40 °F...+212 °F (-40 °C...+100 °C)
	NBR (piston pressure switch) -22 °F...+212 °F (-30 °C...+100 °C)
	EPDM -22 °F...+248 °F (-30 °C...+120 °C)
	FKM (Viton®) (in diaphragm pressure switch) +23 °F...+248 °F (-5 °C...+120 °C)
	FKM (Viton®) (in piston pressure switch) +5 °F...+248 °F (-15 °C...+120 °C)
	FFKM +5 °F...+248 °F (-15 °C...+120 °C)
	Silicone -4 °F...+248 °F (-20 °C...+120 °C)
HNBR -22 °F...+248 °F (-30 °C...+120 °C)	
Switching frequency:	200 / min.
Mechanical life expectancy:	1,000,000 cycles (for diaphragm pressure switches, life expectancy value only applies for switching pressures to max. 725 psi (50 bar))
Pressure rise rate:	≤ 14,500 psi/s (1,000 bar/s)
Differential:	Average value 10 – 20 % (not adjustable)
Vibration resistance:	10 g / 5 – 200 Hz sine wave, DIN EN 60068-2-6
Shock resistance:	294 m/s <sup>2</sup> ; 14 ms half sine wave, DIN EN 60068-2-6
Materials:	Housing material: zinc-plated steel Protective cap: anodised aluminium
Protection class:	IP67
Cable:	Standard length 6.5 ft (2 m) with wire end sleeves
Weight:	approx. 4.5 oz (120 g)

### Options for 0240 / 0241

- Other cable lengths and plug-in systems
- Fixed switching point, factory-set, set point embossed on housing
- Alternative housing materials and connection threads
- Other sealing materials, such as silicone for diaphragm pressure switches

# 0240 / 0241

Diaphragm / piston pressure switches, hex 27

- Zinc-plated steel (CrVI-free)
- Overpressure safety up to 4,350 / 8,700 psi (300 / 600 bar)<sup>1)</sup>
- Switching point can also be adjusted during use
- Protection class 2, protective insulation

p <sub>max.</sub> in psi (bar)	Adjustment range in psi (bar)	Tolerance in psi (bar) at room temperature	Male thread	Order number
-----------------------------------	----------------------------------	---	-------------	--------------

## 0240 Diaphragm pressure switches

4,350 psi <sup>1)</sup> (300 bar) <sup>1)</sup>	4.35 - 21.75 psi (0.3 - 1.5 bar)	± 2.90 psi (± 0.2 bar)	1/4" BSPP	0240 - 457 03 - X - 003
			1/8" NPT	0240 - 457 04 - X - 300
			1/4" NPT	0240 - 457 09 - X - 305
			7/16-20 UNF	0240 - 457 20 - X - 310
			9/16-18 UNF	0240 - 457 21 - X - 315
	14.5 - 145 psi (1 - 10 bar)	± 7.25 psi (± 0.5 bar)	1/4" BSPP	0240 - 458 03 - X - 006
			1/8" NPT	0240 - 458 04 - X - 301
			1/4" NPT	0240 - 458 09 - X - 306
			7/16-20 UNF	0240 - 458 20 - X - 311
			9/16-18 UNF	0240 - 458 21 - X - 316
	145 - 290 psi (10 - 20 bar)	± 14.5 psi (± 1.0 bar)	1/4" BSPP	0240 - 459 03 - X - 009
			1/8" NPT	0240 - 459 04 - X - 302
			1/4" NPT	0240 - 459 09 - X - 307
			7/16-20 UNF	0240 - 459 20 - X - 312
			9/16-18 UNF	0240 - 459 21 - X - 317
	290 - 725 psi (20 - 50 bar)	± 29.0 psi (± 2.0 bar)	1/4" BSPP	0240 - 461 03 - X - 012
1/8" NPT			0240 - 461 04 - X - 303	
1/4" NPT			0240 - 461 09 - X - 308	
7/16-20 UNF			0240 - 461 20 - X - 313	
9/16-18 UNF			0240 - 461 21 - X - 318	

## 0241 Piston pressure switches

8,700 psi <sup>1)</sup> (600 bar) <sup>1)</sup>	725 - 2,175 psi (50 - 150 bar)	± 72.5 psi (± 5.0 bar)	1/4" BSPP	0241 - 460 03 - X - 003
			1/8" NPT	0241 - 460 04 - X - 304
			1/4" NPT	0241 - 460 09 - X - 309
			7/16-20 UNF	0241 - 460 20 - X - 314
			9/16-18 UNF	0241 - 460 21 - X - 319

## Seal material – Application areas

NBR (BunaN)	Hydraulic/machine oil, heating oil, air, nitrogen <sup>2)</sup> , etc.	1
EPDM	EPDM Brake fluid, water, hydrogen, oxygen, acetylene <sup>2)</sup> , etc.	2
FKM (Viton®)	Hydraulic fluids (HFA, HFB, HFD), petrol/gasoline, etc.	3
FFKM	Hot water, chemical acids, diluted alkalis, ketones, esters, alcohols	6
HNBR	Hydraulic/machine oil, ester-based bio-oils	9

Refer to page 64 for the temperature range and application thresholds of sealing materials. ↓

Your order number: 024X - XXX XX - X - XXX

# M.5

hex 24 / 27  
Ready-wired

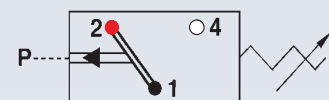
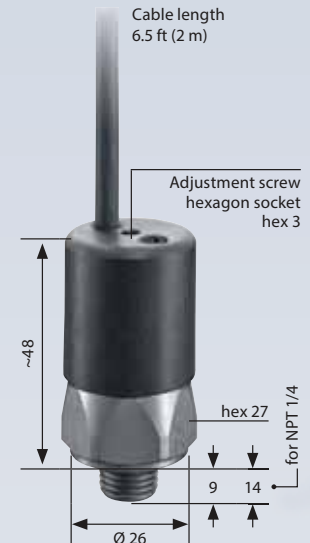

Contact assignment:

- 1 = Black
- 2 = Red
- 4 = White

1) Static value. Dynamic value is 30-50 % lower. Values pertain to the hydraulic/pneumatic part of the pressure switch.  
2) For gas applications below 10 bar (145 PSI) we generally recommend venting the housing for encapsulated pressure switches. Please contact us so we can offer you a suitable solution.



M.6  
hex 24  
PS **PLUS**

## Pressure switches *PLUS*

with integrated connector and supplementary functions

Hex 24, NC or NO, voltage up to 42 V



**Intelligent, supplementary electronic functions broaden the capabilities of mechanical pressure switches by adding numerous features:**

- NAMUR diagnostic function (fail-safe) with short-circuit and cable break detection
- Overvoltage protection for prolonging the contact service life
- Active reduction of EMC emissions
- Temperature-controlled switching function (e.g. cold start, i.e. inactive switching function until a certain temperature is reached)
- In-rush current limitation (overload limitation of the switching contacts when switching load is too high, e.g. lamp load, motor start-up)
- Display of the switching status with LED
- Overload protection with self-resetting electrical fuse
- High protection class up to IP67 and IP6K9K
- Switching point can be set on site with adjusting screw in the connector<sup>1)</sup>

<sup>1)</sup> Pressure switches can also be supplied preset at factory.  
The switching point is embossed onto pressure switches preset at factory.

# Pressure switches *PLUS*

with integrated connector and supplementary functions

M.6  
hex 24  
PS *PLUS*

## Overview of possible supplementary functions

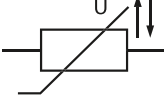
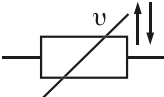
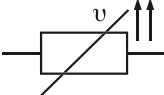
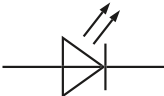
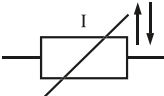
Circuit	Symbole	Function	Application	Code for order number
<b>Resistor</b> Resistor circuit to NAMUR, refer to page 68		<ul style="list-style-type: none"> <li>Diagnostic function (fail-safe) with short-circuit and cable break detection</li> </ul>	Safety systems such as brake systems, hydrostatic steering systems and fire extinguisher systems	04XX - R
<b>Varistor</b> Circuit with varistor for overvoltage limitation, refer to page 69		<ul style="list-style-type: none"> <li>Overvoltage protection for the prolonging of contact service life under conditions of inductive load and long connection length</li> <li>Active reduction of EMC emissions on switching of the pressure switch</li> </ul>	The flyback voltage is effectively limited if the pressure switch interrupts the current in circuits with magnetic valves, relays or motors	04XX - V
<b>NTC thermistor</b>		<ul style="list-style-type: none"> <li>Temperature-controlled switch behaviour (e.g. filter monitoring)</li> <li>In-rush current limitation, e.g. for motors („soft start“) and in PSUs</li> <li>On-delay (in series) and dropout delay (in parallel) for relays</li> </ul>	For a cold start in a mobile hydraulic application, a pressure switch used for filter monitoring may activate due to the high viscosity of the oil at low temperatures, and signals a blocked filter. The NTC thermistor integrated in the pressure switch means the circuit remains interrupted until the pressure switch, and so also the thermistor, have warmed up; not until then does the circuit become low impedance.	04XX - N
<b>PTC thermistor</b>		<ul style="list-style-type: none"> <li>Protection against overcurrent</li> <li>In-rush current limitation, such as for filament lamps and condenser load</li> </ul>	E.g. brake light monitoring in mobile hydraulics: The in-rush current can be up to 8 times the nominal current of a filament lamp. This high current is only reduced at the moment of switch-on, thereby protecting the contact system of the pressure switch from overload.	upon request <sup>1)</sup>
<b>LED</b>		<ul style="list-style-type: none"> <li>Displays the switching status by an integrated LED</li> </ul>	Direct switching status display for applications in which the controller is physically remote; e.g. in an automation system or permanently installed extinguishing or gas systems.	upon request <sup>1)</sup>
<b>Multifuse, PPTC</b>		<ul style="list-style-type: none"> <li>Protection against overcurrent</li> <li>Self-resetting: After removing the short-circuit (cooling the MF) the fuse resets</li> </ul>	In applications which need to be protected against overcurrent e.g. electronic applications	upon request <sup>1)</sup>

<sup>1)</sup> Available from a minimum order quantity of 2,000 pieces.

M.6  
hex 24  
PS PLUS

# Pressure switches PLUS

Resistor circuit to NAMUR, with gold contacts  
(pressure switches with part numbers 04XX-R)

The additional circuitry of the switching contact of the pressure switch enables not only the states to be shown enabled and disabled, it also enables interrogation for line breaks (standby current principle) and short-circuits in the electric circuit.

The resistor circuitry is designed such that the NAMUR specifications can be satisfied. An operating voltage of 8.2 VDC must be provided for NAMUR-compliant operation. A resistance of 11 kΩ is present in the circuit when the switch contact is open. The resistance is 1 kΩ when the switch contact is closed. Other resistance values can also be realised.

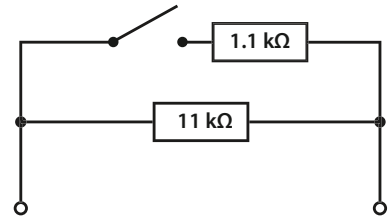

Switching status	Closed	Open	Short-circuit SC	Line Break LB
<b>Contact</b>				
<b>Resistor</b>				
<b>Current</b>				
<b>Example:</b> Supply voltage 12VDC	$I = \frac{U_{cc}}{1\text{ k}\Omega} = \frac{12\text{ V}}{1\text{ k}\Omega} = 12\text{ mA}$	$I = \frac{U_{cc}}{11\text{ k}\Omega} = \frac{12\text{ V}}{11\text{ k}\Omega} = 1,1\text{ mA}$	$I \gg \frac{U_{cc}}{1\text{ k}\Omega} \quad I \gg \frac{12\text{ V}}{1\text{ k}\Omega} \quad I \gg 12\text{ mA}$	$I = 0\text{ mA}$

Technical details	
Rated working voltage U <sub>cc</sub> :	8.2 VDC ... 30 VDC
Maximum rated operating current:	≤ 30 mA
Switching capacity:	< 1 W
Switching frequency:	200 / min.
Mechanical and electrical service life:	1,000,000 cycles
Permitted pressure rise rate:	≤ 1,000 bar / s
Vibration resistance:	10 g; 5 ... 200 Hz sine wave; DIN EN 60068-2-6
Shock resistance:	294 m/s <sup>2</sup> ; 14 ms half sine wave; DIN EN 60068-2-27
Protection class:	Refer to the table on the following pages: According to manufacturer specifications for the respective plug-in system (only when plugged in), otherwise IP00.

# Pressure switches *PLUS*

Circuit with varistor for overvoltage limitation  
(pressure switches with part numbers 04XX-V)

M.6  
hex 24  
PS *PLUS*

The switching off inductive consumers such as valves, relays and motors by a mechanical pressure switch generates a high voltage peak. The cause for this is the energy stored in the magnetic field of inductance, which entails an induction voltage when the current is changed.

The induction voltage (or flyback voltage) is defined as follows:

$$U_L = -L \frac{di}{dt}$$

where  $L$  = Inductance  
 $di/dt$  = Change of current over time

This induction voltage can result in discharge effects and the occurrence of arcs at the opening contacts. This gives rise to localised, very hot places on the contact surfaces which are able to fuse the contact material. Increasing load damages the contact surface and the contact transition resistance rises. This can result in sporadic interruption, adhesion and welding of the contacts, and so lead to complete failure of the pressure switch.

The effect of induction voltage is countered by means of a varistor – a resistor which reduces its ohmic resistance with increasing connection voltage. The induction voltage is limited to the responding value of the varistor, and the energy is converted to heat in the varistor.

Varistors are suitable for DC and AC in equal measure. In DC circuits, the response voltage of the varistor must be greater than the highest value of the supply voltage. In AC circuits, it must be 1.5 times the peak-to-peak value of the supply voltage.

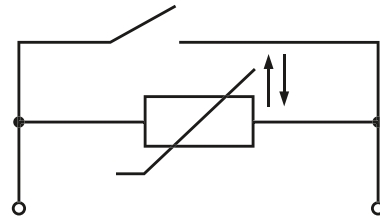

Technical details	
Rated operating voltage Ucc:	10 V ... 24 ... 30 VDC / 10 V ... 21 VAC
Rated operating current, ohmic load DC12 / AC12:	10 mA ... 4 A
Rated operating current, inductive load DC13 / AC13:	10 mA ... 1 A
AC / DC switching capacity:	< 100 W / 100 VA
Switching frequency:	200 / min.
Varistor response voltage:	41 VDC ± 10 % at 1 mA
Maximum varistor energy:	0.4 J (10/1000 µs); 0.3 J (2 ms)
Maximum varistor peak current:	120 A (8/20 µs, one-off loading), 60 A (8/20 µs, dual loading)
Mechanical service life:	1,000,000 cycles
Permitted pressure rise rate:	≤ 1,000 bar / s
Vibration resistance:	10 g; 5 – 200 Hz sine wave; DIN EN 60068-2-6
Shock resistance:	294 m/s <sup>2</sup> ; 14 ms half sine wave; DIN EN 60068-2-27
Protection class:	Refer to the table on the following pages: According to manufacturer specifications for the respective plug-in system (only when plugged in), otherwise IP00.

M.6  
hex 24  
PS PLUS



**0410 / 0411**  
**Deutsch DT04-2P**  
IP67, IP6K9K



**0412 / 0413**  
**AMP Superseal 1.5°**  
IP67



**0414 / 0415**  
**Packard MetriPack 280°**  
IP67



**0416 / 0417**  
**Deutsch DT04-3P**  
IP67, IP6K9K



**0418 / 0419**  
**AMP Junior Timer°**  
IP65, IPx4K



**0422 / 0423**  
**M12x1 DIN EN 61076-2-101-A**  
IP67



**0424 / 0425**  
**M12x1 DIN EN 60947-5-2**  
IP67

# 0410 / 0412 / 0414 / 0416 / 0418 / 0422 / 0424

Diaphragm pressure switches, up to 42 V  
with supplementary functions

- Zinc-plated steel (CrVI-free)
- Overpressure safety up to 4,350 psi (300 bar)<sup>1)</sup>
- Burst pressure safety up to 5,800 psi (400 bar)<sup>1)</sup>

### Plug-in types for diaphragm pressure switches

Deutsch DT04-2P	0410 - XXX XX - X - 001	0410 - XXX XX - X - 002
AMP Superseal 1.5°	0412 - XXX XX - X - 001	0412 - XXX XX - X - 002
Packard MetriPack 280	0414 - XXX XX - X - 001	0414 - XXX XX - X - 002
Deutsch DT04-3P	0416 - XXX XX - X - 001	0416 - XXX XX - X - 002
AMP Junior Timer°	0418 - XXX XX - X - 001	0418 - XXX XX - X - 002
M12x1 DIN EN 61076-2-101-A (PIN 1+3)	0422 - XXX XX - X - 001	0422 - XXX XX - X - 002
M12x1 DIN EN 60947-5-2 (PIN 1+2 / PIN 1+4)	0424 - XXX XX - X - 001	0424 - XXX XX - X - 002

Adjustment range (tolerance at room temperature)	Male thread	Article number NO →  :	Article number NC → :
---	-------------	---------------------------	--------------------------

### 04XX Diaphragm pressure switches

1.45 - 14.5 ± 2.90 psi 0.1 - 1 (± 0.2) bar	M 10x1 taper	04XX - X 03 01 - X - 001	04XX - X 04 01 - X - 002
	1/4" BSPP	04XX - X 03 03 - X - 001	04XX - X 04 03 - X - 002
	1/8" NPT	04XX - X 03 04 - X - 001	04XX - X 04 04 - X - 002
	1/4" NPT	04XX - X 03 09 - X - 001	04XX - X 04 09 - X - 002
	7/16-20 UNF	04XX - X 03 20 - X - 001	04XX - X 04 20 - X - 002
7.25- 43.5 ± 4.35 psi 0.5 - 3 (± 0.3) bar	9/16-18 UNF	04XX - X 03 21 - X - 001	04XX - X 04 21 - X - 002
	M 10x1 taper	04XX - X 23 01 - X - 001	04XX - X 24 01 - X - 002
	1/4" BSPP	04XX - X 23 03 - X - 001	04XX - X 24 03 - X - 002
	1/8" NPT	04XX - X 23 04 - X - 001	04XX - X 24 04 - X - 002
	1/4" NPT	04XX - X 23 09 - X - 001	04XX - X 24 09 - X - 002
14.5 - 145 ± 7.25 psi 1 - 10 (± 0.5) bar	7/16-20 UNF	04XX - X 23 20 - X - 001	04XX - X 24 20 - X - 002
	9/16-18 UNF	04XX - X 23 21 - X - 001	04XX - X 24 21 - X - 002
	M 10x1 taper	04XX - X 07 01 - X - 001	04XX - X 08 01 - X - 002
	1/4" BSPP	04XX - X 07 03 - X - 001	04XX - X 08 03 - X - 002
	1/8" NPT	04XX - X 07 04 - X - 001	04XX - X 08 04 - X - 002
	1/4" NPT	04XX - X 07 09 - X - 001	04XX - X 08 09 - X - 002
	7/16-20 UNF	04XX - X 07 20 - X - 001	04XX - X 08 20 - X - 002
	9/16-18 UNF	04XX - X 07 21 - X - 001	04XX - X 08 21 - X - 002

### Supplementary functions<sup>2)</sup>

Resistor	Diagnostics function	R XX XX
Varistor	Overvoltage protection	V XX XX
NTC thermistor	Filter monitoring	N XX XX

### Seal material – Application areas

NBR	Hydraulic/machine oil, air, nitrogen, etc.	1
EPDM	Brake fluid, water, hydrogen, oxygen, acetylene, etc.	2
FKM	Hydraulic fluids (HFA, HFB, HFD), petrol/gasoline, etc.	3
FFKM	Hot water, chemical acids, diluted alkalis, ketones, esters, alcohols	6
HNBR	Hydraulic/machine oil, ester-based bio-oils	9

Refer to page 24 for the temperature range and application thresholds of sealing materials.

Article number: **04XX - XXX XX - X - 00X**

<sup>1)</sup> Static value. Dynamic value is 30-50 % lower. Values pertain to the hydraulic/pneumatic part of the pressure switch.

<sup>2)</sup> Other versions available depending on minimum order quantity (see p. 67)

# 0410 / 0412 / 0414 / 0416 / 0418 / 0422 / 0424

Diaphragm pressure switches, up to 42 V  
with supplementary functions

- Zinc-plated steel (CrVI-free)
- Overpressure safety up to 4,350 psi (300 bar)<sup>1)</sup>
- Burst pressure safety up to 5,800 psi (400 bar)<sup>1)</sup>

## Plug-in types for diaphragm pressure switches

Deutsch DT04-2P	0410 - XXX XX - X - 001	0410 - XXX XX - X - 002
AMP Superseal 1.5®	0412 - XXX XX - X - 001	0412 - XXX XX - X - 002
Packard MetriPack 280	0414 - XXX XX - X - 001	0414 - XXX XX - X - 002
Deutsch DT04-3P	0416 - XXX XX - X - 001	0416 - XXX XX - X - 002
AMP Junior Timer®	0418 - XXX XX - X - 001	0418 - XXX XX - X - 002
M12x1 DIN EN 61076-2-101-A (PIN 1+3)	0422 - XXX XX - X - 001	0422 - XXX XX - X - 002
M12x1 DIN EN 60947-5-2 (PIN 1+2 / PIN 1+4)	0424 - XXX XX - X - 001	0424 - XXX XX - X - 002

Adjustment range (tolerance at room temperature)	Male thread	Article number NO → :	Article number NC → >:
---	----------------	--------------------------	---------------------------

## 04XX Diaphragm pressure switches

145 - 290 ± 14.50 psi 10 - 20 (± 1) bar	M 10x1 taper	04XX - X 11 01 - X - 001	04XX - X 12 01 - X - 002
	1/4" BSPP	04XX - X 11 03 - X - 001	04XX - X 12 03 - X - 002
	1/8" NPT	04XX - X 11 04 - X - 001	04XX - X 12 04 - X - 002
	1/4" NPT	04XX - X 11 09 - X - 001	04XX - X 12 09 - X - 002
	7/16-20 UNF	04XX - X 11 20 - X - 001	04XX - X 12 20 - X - 002
	9/16-18 UNF	04XX - X 11 21 - X - 001	04XX - X 12 21 - X - 002

290 - 725 ± 29.0 psi 20 - 50 (± 2) bar	M 10x1 taper	04XX - X 15 01 - X - 001	04XX - X 16 01 - X - 002
	1/4" BSPP	04XX - X 15 03 - X - 001	04XX - X 16 03 - X - 002
	1/8" NPT	04XX - X 15 04 - X - 001	04XX - X 16 04 - X - 002
	1/4" NPT	04XX - X 15 09 - X - 001	04XX - X 16 09 - X - 002
	7/16-20 UNF	04XX - X 15 20 - X - 001	04XX - X 16 20 - X - 002
	9/16-18 UNF	04XX - X 15 21 - X - 001	04XX - X 16 21 - X - 002

## Supplementary functions<sup>2)</sup>

Resistor	Diagnostics function	R XX XX
Varistor	Overvoltage protection	V XX XX
NTC thermistor	Filter monitoring	N XX XX

## Seal material – Application areas

NBR	Hydraulic/machine oil, air, nitrogen, etc.	1
EPDM	Brake fluid, water, hydrogen, oxygen, acetylene, etc.	2
FKM	Hydraulic fluids (HFA, HFB, HFD), petrol/gasoline, etc.	3
FFKM	Hot water, chemical acids, diluted alkalis, ketones, esters, alcohols	6
HNBR	Hydraulic/machine oil, ester-based bio-oils	9

Refer to page 24 for the temperature range and application thresholds of sealing materials.

Article number: 04XX - XXX XX - X - 00X

M.6  
hex 24  
PS PLUS



<sup>1)</sup> Static value. Dynamic value is 30-50 % lower. Values pertain to the hydraulic/pneumatic part of the pressure switch.

<sup>2)</sup> Other versions available depending on minimum order quantity (see p. 67)

M.6  
hex 24  
PS PLUS



0411 / 0413 / 0415 / 0417 / 0419 / 0423 / 0425

Piston pressure switches, up to 42 V with supplementary functions

- Zinc-plated steel (CrVI-free)
- Overpressure safety up to 4,350 psi (600 bar)<sup>1)</sup>
- Overpressure safety up to 5,800 psi (700 bar)<sup>1)</sup>

Plug-in types for piston pressure switches

Deutsch DT04-2P	0411 - XXX XX - X - 001	0411 - XXX XX - X - 002
AMP Superseal 1.5®	0413 - XXX XX - X - 001	0413 - XXX XX - X - 002
Packard MetriPack 280	0415 - XXX XX - X - 001	0415 - XXX XX - X - 002
Deutsch DT04-3P	0417 - XXX XX - X - 001	0417 - XXX XX - X - 002
AMP Junior Timer®	0419 - XXX XX - X - 001	0419 - XXX XX - X - 002
M12x1 DIN EN 61076-2-101-A (PIN 1+3)	0423 - XXX XX - X - 001	0423 - XXX XX - X - 002
M12x1 DIN EN 60947-5-2 (PIN 1+2 / PIN 1+4)	0425 - XXX XX - X - 001	0425 - XXX XX - X - 002

Adjustment range (tolerance at room temperature)	Male thread	Article number NO →  :	Article number NC → :
---	----------------	---------------------------	--------------------------

04XX Piston pressure switches

725 - 2,175 ± 72.5 psi 50 - 150 (± 5.0) bar	M 10x1 taper	04XX - X 19 01 - X - 001	04XX - X 20 01 - X - 002
	1/4" BSPP	04XX - X 19 03 - X - 001	04XX - X 20 03 - X - 002
	1/8" NPT	04XX - X 19 04 - X - 001	04XX - X 20 04 - X - 002
	1/4" NPT	04XX - X 19 09 - X - 001	04XX - X 20 09 - X - 002
	7/16-20 UNF	04XX - X 19 20 - X - 001	04XX - X 20 20 - X - 002
	9/16-18 UNF	04XX - X 19 21 - X - 001	04XX - X 20 21 - X - 002



Supplementary functions<sup>2)</sup>

Resistor	Diagnostics function	R XX XX
Varistor	Overvoltage protection	V XX XX
NTC thermistor	Filter monitoring	N XX XX



Seal material – Application areas

NBR (BunaN)	Hydraulic/machine oil, air, nitrogen, etc.	1
EPDM	Brake fluid, water, hydrogen, oxygen, acetylene, etc.	2
FKM (Viton)	Hydraulic fluids (HFA, HFB, HFD), petrol/gasoline, etc.	3
HNBR	Hydraulic/machine oil, ester-based bio-oils	9

Refer to page 24 for the temperature range and application thresholds of sealing materials.



Article number:	04XX - XXX XX - X - 00X
-----------------	-------------------------

<sup>1)</sup> Static value. Dynamic value is 30-50 % lower. Values pertain to the hydraulic/pneumatic part of the pressure switch.

<sup>2)</sup> Other versions available depending on minimum order quantity (see p. 67)

# Pressure switches *PLUS*

Plug-in types for diaphragm and piston pressure switches

M.6  
hex 24  
PS *PLUS*

## Technical details of plug-in types

0410 / 0411	0412 / 0413	0414 / 0415
		
<b>Deutsch DT04-2P</b>	<b>AMP Superseal 1.5®</b>	<b>Packard MetriPack 280®</b>
IP67, IP6K9K	IP67	IP67
H ≈ 61 mm	H ≈ 61 mm	H ≈ 62 mm
		

◀ Model / type

◀ Connector

◀ Protection class

◀ Overall height

◀ Contact assignment

M

0416 / 0417	0418 / 0419	0422 / 0423	0424 / 0425
			
<b>Deutsch DT04-3P</b>	<b>AMP Junior Timer®</b>	<b>M12x1 DIN EN 61076-2-101-A</b>	<b>M12x1 DIN EN 60947-5-2</b>
IP67, IP6K9K	IP65, IPx4K	IP67	IP67
H ≈ 63 mm	H ≈ 54 mm	H ≈ 51 mm	H ≈ 51 mm
	 Not recommended for new applications	 1: brown 3: blue	 1: brown 2: black 4: white

◀ Model / type

◀ Connector

◀ Protection class

◀ Overall height

◀ Contact assignment

M.7

30 A/F

# Pressure switches 30 A/F

Snap action with silver contacts



- Attachment options for wall fitting and block style enable clearly structured, accessible, easy-maintenance installation
- Switching pressure can be adjusted easily by user
- High overpressure safety
- Socket devices enable simple installation on the machine

# Pressure switches 30 A/F

## Technical data

# M.7

## 30 A/F

Temperature resistance of sealing materials:	NBR (diaphragm pressure switch) -40 °F...+212 °F (-40 °C...+100 °C)
	NBR (piston pressure switch) -22 °F...+212 °F (-30 °C...+100 °C)
	EPDM -22 °F...+248 °F (-30 °C...+120 °C)
	FKM (Viton®) (in diaphragm pressure switch) +23 °F...+248 °F (-5 °C...+120 °C)
	FKM (Viton®) (in piston pressure switch) +5 °F...+248 °F (-15 °C...+120 °C)
Switching frequency:	200 / min.
Mechanical life expectancy:	1,000,000 cycles (for diaphragm pressure switches, life expectancy value only applies for switching pressures up to 725 psi / 50 bar)
Pressure rise rate:	≤ 1,450 psi / s (≤ 1,000 bar / s)
Differential:	Typ 0159: approx. 10 ... 30 % (not adjustable)
	Types 0161, 0162, 0175: approx. 10 ... 30 % (factory adjustable)
Vibration resistance:	10 g; 5 ... 200 Hz sine wave; DIN EN 60068-2-6
Shock resistance:	294 m/s <sup>2</sup> ; 14 ms half sine wave; DIN EN 60068-2-27
Housing material:	Aluminium
Protection class:	IP65 with Socket device fitted
Weight:	Typ 0159, 0161, 0162: approx. 8.5 oz (240 g)
	Typ 0175: approx. 11 oz (310 g)

Electrical values	0159	0161 / 0162 / 0175
Rated working voltage $U_r$	Rated working current $I_r$	
250 VAC 50 / 60 Hz, AC 12	2.5 A	5 A
250 VAC 50 / 60 Hz, AC 14	1 A	1 A
24 VDC, DC 12 / DC 13	2 / 2 A	3.5 / 3.5 A
50 VDC, DC 12 / DC 13	1 / 0.5 A	2 / 1 A
75 VDC, DC 12 / DC 13	0.75 / 0.4 A	1 / 0.5 A
125 VDC, DC 12 / DC 13	0.3 / 0.2 A	0.3 / 0.2 A
250 VDC, DC 12 / DC 13	0.3 / 0.2 A	0.25 / 0.2 A
Rated insulation voltage $U_i$	300 V	
Rated impulse withstand voltage $U_{imp}$ :	2.5 kV	
Conventional thermal current $I_{the}$ :	6 A	
Switching overvoltage:	< 2.5 kV	
Rated frequency:	DC and 50 / 60 Hz	
Nominal current of short-circuit mechanism:	to 2.5 A	to 6.3 A
Conditional short-circuit current:	< 350 A	
Tightening torque of terminal screws:	< 0.35 Nm	
Connector cross-section:	0.5 – 1.5 mm <sup>2</sup>	

M.7

30 A/F

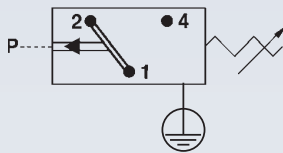
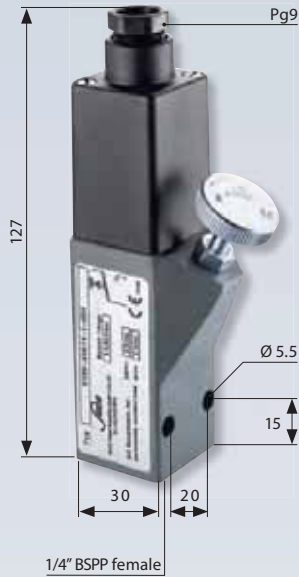

# 0159

Diaphragm / piston pressure switch up to 250 V

- Aluminium housing
- Snap action with silver contacts
- Overpressure safety up to 2,900 / 8,700 psi (200 / 600 bar)<sup>1)</sup>
- Switching point continuously adjustable by turning knurled screw whilst system in operation

P <sub>max.</sub> in psi (bar)	Adjustment range in psi (bar)	Tolerance in psi (bar) at room temperature	Thread	Order number:
-----------------------------------	----------------------------------	---	--------	---------------

With female thread

### 0159 Diaphragm pressure switches

2,900 psi <sup>1)</sup> (200 bar) <sup>1)</sup>	2.90 - 29 psi (0.2 - 2 bar)	± 2.90 - 4.35 psi (± 0.2 - 0.3 bar)	1/4" BSPP female	0159 - 426 14 - X - 001
	7.25 - 72.5 psi (0.5 - 5 bar)	± 2.90 - 7.25 psi (± 0.2 - 0.5 bar)		0159 - 427 14 - X - 001
	14.5 - 145 psi (1 - 10 bar)	± 7.25 psi (± 0.5 bar)		0159 - 428 14 - X - 001
	29 - 290 psi (2 - 20 bar)	± 14.5 psi (± 1.0 bar)		0159 - 429 14 - X - 001
	72.5 - 725 psi (5 - 50 bar)	± 43.5 psi (± 3.0 bar)		0159 - 430 14 - X - 001
	145 - 1,450 psi (10 - 100 bar)	± 43.5 - 72.5 psi (± 3.0 - 5.0 bar)		0159 - 431 14 - X - 001

### 0159 Piston pressure switches

8,700 psi <sup>1)</sup> (600 bar) <sup>1)</sup>	145 - 1,450 psi (10 - 100 bar)	± 43.5 - 72.5 psi (± 3.0 - 5.0 bar)	1/4" BSPP female	0159 - 432 14 - X - 001
	362.5 - 3,625 psi (25 - 250 bar)	± 72.5 - 101.5 psi (± 5.0 - 7.0 bar)		0159 - 433 14 - X - 001
	580 - 5,800 psi (40 - 400 bar)	± 72.5 - 130.5 psi (± 5.0 - 9.0 bar)		0159 - 434 14 - X - 001

### Seal material – Application areas

NBR (BunaN)	Hydraulic/machine oil, heating oil, air, nitrogen, etc.	1
EPDM	Brake fluid, hydrogen, oxygen, acetylene, etc.	2
FKM (Viton®)	Hydraulic fluids (HFA, HFB, HFD), petrol/gasoline, etc.	3

Refer to page 75 for the temperature range and application thresholds of sealing materials



Your order number: **0159 - XXX 14 - X - XXX**



<sup>1)</sup> Static value. Dynamic value is 30-50 % lower. Values pertain to the hydraulic/pneumatic part of the pressure switch.

# 0161 / 0162

Diaphragm / piston pressure switches up to 250 V

- Aluminium housing
- Snap action with silver contacts
- Overpressure safety up to 2,900 / 8,700 psi (200 / 600 bar)<sup>1)</sup>
- Socket device similar to DIN EN 175301 (DIN 43650)
- Differential adjustable at factory

P <sub>max.</sub> in psi (bar)	Adjustment range in psi (bar)	Tolerance in psi (bar) at room temperature	Dimension A in mm	Order number:
-----------------------------------	----------------------------------	---	----------------------	---------------

With female 1/4 BSPP thread

## 0161 Diaphragm pressure switches

2,900 psi <sup>1)</sup> (200 bar) <sup>1)</sup>	7.25 - 14.5 psi (0.5 - 1 bar)	± 2.90 psi (± 0.2 bar)		0161 - 436 14 - X - 001
	7.25 - 72.5 psi (0.5 - 5 bar)	± 2.90 - 72.5 psi (± 0.2 - 0.5 bar)		0161 - 437 14 - X - 001
	14.5 - 145 psi (1 - 10 bar)	± 7.25 psi (± 0.5 bar)		0161 - 438 14 - X - 001
	145 - 725 psi (10 - 50 bar)	± 43.5 psi (± 3.0 bar)		0161 - 439 14 - X - 001
	725 - 1,450 psi (50 - 100 bar)	± 43.5 - 72.5 psi (± 3.0 - 5.0 bar)		0161 - 440 14 - X - 001

## 0161 Piston pressure switches

8,700 psi <sup>1)</sup> (600 bar) <sup>1)</sup>	1,450 - 5,800 psi (100 - 400 bar)	± 72.5 - 130.5 psi (± 5.0 - 9.0 bar)		0161 - 441 14 - X - 001
--	--------------------------------------	---	--	-------------------------

Block style (with O-ring NBR 5 x 1.5 mm)

## 0162 Diaphragm pressure switches

2,900 psi <sup>1)</sup> (200 bar) <sup>1)</sup>	7.25 - 14.5 psi (0.5 - 1 bar)	± 2.90 psi (± 0.2 bar)	15	0162 - 436 14 - X - 001
	7.25 - 72.5 psi (0.5 - 5 bar)	± 2.90 - 72.5 psi (± 0.2 - 0.5 bar)		0162 - 437 14 - X - 001
	14.5 - 145 psi (1 - 10 bar)	± 7.25 psi (± 0.5 bar)		0162 - 438 14 - X - 001
	145 - 725 psi (10 - 50 bar)	± 43.5 psi (± 3.0 bar)		0162 - 439 14 - X - 001
	725 - 1,450 psi (50 - 100 bar)	± 43.5 - 72.5 psi (± 3.0 - 5.0 bar)		0162 - 440 14 - X - 001

## 0162 Piston pressure switches

8,700 psi <sup>1)</sup> (600 bar) <sup>1)</sup>	1,450 - 5,800 psi (100 - 400 bar)	± 72.5 - 130.5 psi (± 5.0 - 9.0 bar)	19.5	0162 - 441 14 - X - 001
--	--------------------------------------	---	------	-------------------------

## Seal material – Application areas

NBR (BunaN)	Hydraulic/machine oil, heating oil, air, nitrogen, etc.	1
EPDM	Brake fluid, hydrogen, oxygen, acetylene, etc.	2
FKM (Viton®)	Hydraulic fluids (HFA, HFB, HFD), petrol/gasoline, etc.	3

Refer to page 75 for the temperature range and application thresholds of sealing materials

**Your order number:** 016X - XXX 14 - X - XXX

### 1 Adjusting the set point

To adjust the set point, undo the locknut and adjust the set screw using a screwdriver.  
Clockwise screwing increases the switching pressure. After adjusting, tighten the locknut again.

<sup>1)</sup> Static value. Dynamic value is 30-50% lower. Values pertain to the hydraulic/pneumatic part of the pressure switch.

M.7

30 A/F

## 0161 with female thread

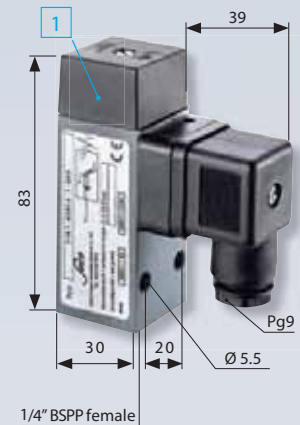

## 0162 Block style

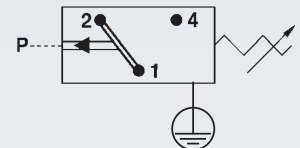
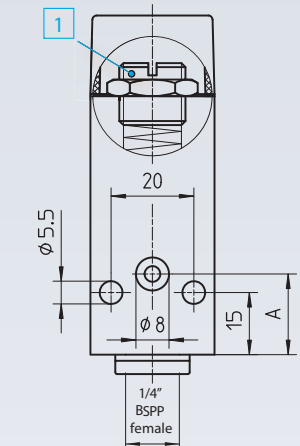

# M.7

30 A/F

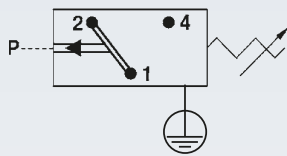

## 0175

Diaphragm pressure switches up to 250 V

- For low pressure, high accuracy
- Aluminium housing
- Changeover with silver contacts
- Overpressure safety up to 363 psi (25 bar)<sup>1)</sup>
- Socket device similar to DIN EN 175301 (DIN 43650)
- Hysteresis adjustable at factory

p <sub>max</sub> in bar	Adjustment range in bar	Tolerance at room temperature in bar	Thread	Article number
----------------------------	----------------------------	---	--------	----------------

With female thread

### 0175 Diaphragm pressure switches

363 psi (25 bar) <sup>1)</sup>	0.1 – 1	± 0.1 – 0.2	G 1/4 female	0175 - 435 14 - 1 - 001
--------------------------------	---------	-------------	--------------	-------------------------

### Seal material – Application areas

NBR	Hydraulic/machine oil, air, nitrogen, etc.
	Temperature resistance: -30 °C ... +100 °C

Article number:

0175 - 435 14 - 1 - 001

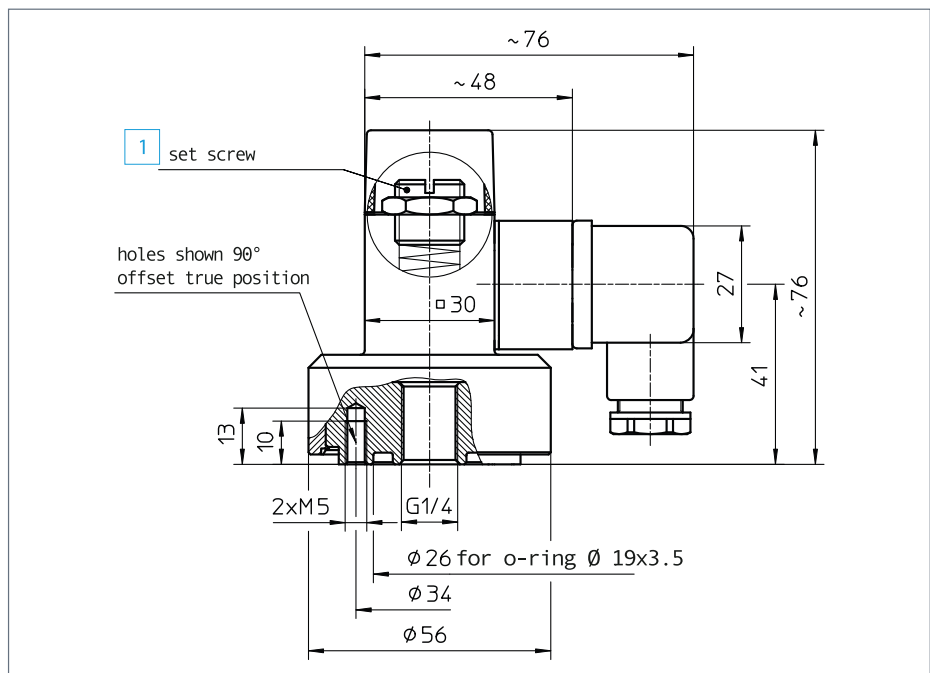

#### 1 Adjusting the set point

To adjust the set point, undo the locknut and adjust the set screw M16 using a screwdriver. Clockwise screwing increases the switching pressure. After adjusting, tighten the locknut again.

<sup>1)</sup> Static value. Dynamic value is 30-50 % lower. Values pertain to the hydraulic/pneumatic part of the pressure switch.



# Explosion-protected pressure switches

according to ATEX directive 2014/34/EU and IECEx scheme



- ATEX certification for the Ex-protected zones:
  - 1 + 2 (Gases and vapours)
  - 21 + 22 (Dust)
  - M2 Mining (Methane / coal dust)
- Types 0342/0343 are certified according to IECEx scheme
- Switching point can be easily adjusted by the user while system in operation
- Compact design
- Excellent price-performance ratio

# Explosion-protected pressure switches

## Technical details

M.8  
ATEX

### Technical explanations

Explosion-protected pressure switches are classified according to the respective combustible material-type. This division is:

<b>Gases and vapours</b> <b>0165, 0342 / 0343</b>	<b>Dusts</b> <b>0340 / 0341, 0342 / 0343</b>	<b>Methane / coal dust</b> <b>0342 / 0343</b>
--	---	--

### ATEX/IECEx marking for pressure switches

Our pressure switches are designed for gases and vapours (G), dust (D) and methane / coal dust (M) in mining:

Series	Flammable materials	Ex zones	Ex marking acc. to 2014/34/EU
0165	Gases and vapours	1 + 2	Ex II 2G Ex d II C T6/T5 X
0340 / 0341	Dusts	22	Ex II 3D Ex tc IIIC T90°C Dc
0342 / 0343	Gases and vapours	1 + 2	Ex II 2G Ex db IIC T6 / T5 Gb
	Dusts	21 + 22	Ex II 2D Ex tb IIIC T80°C/ T100°C Db
	Methane / coal dust	M2 (Mining)	Ex I M2 Ex db I Mb

The following table shows an overview of the explosion protection zones, device groups and categories. The applications covered by our pressure switches (according to Ex zones) are highlighted in colour.

### Conditions in potentially explosive atmosphere

Com-bustible materials	Temporary behaviour of combustible materials in potentially explosive area	Categorisation of potentially explosive areas	Marking required on equipment to be used	
			Equipment group	Equipment category
Gases Vapours	are present continually, frequently or for long periods	Zone 0	II	1G
	occur occasionally	Zone 1	II	2G
	are unlikely to occur, and if so, are then only seldom or for short periods	Zone 2	II	2G
Dusts	are present continually, frequently or for long periods	Zone 20	III	1D
	occur occasionally	Zone 21	III	2D
	occur if accumulated dust is whirled up, and then only seldom or for short periods	Zone 22	III	3D or 2D
Methane / Coal dust	operation where there is a risk of explosions	-	I	M1
	disconnection where there is a risk of explosion	-	I	M2 or M1



# Explosion-protected pressure switches

## Technical details

Type	0165	0340 / 0341	0342 / 0343		
Ex zones:	1 + 2	22	1 + 2	21 + 22	Mining
Flammable materials:	Gases and vapours	Dusts	Gases and vapours	Dusts	Methan / coal dust
Temperature resistance:	NBR		-4 °F... +176 °F (-20 °C ... +80 °C)		
	EPDM		-4 °F... +176 °F (-20 °C ... +80 °C)		
	FKM (Diaphragm pressure switch)		41 °F... +176 °C (-5 °C ... +80 °C)		
	FKM (Piston pressure switch)		5 °F... +176 °C (-15 °C ... +80 °C)		
	FFKM (0340 + 0342 only)		-4 °F... +176 °F (-20 °C ... +80 °C)		
	HNBR		-4 °F... +176 °F (-20 °C ... +80 °C)		
Switching frequency:	200 / min				
Mechanical life expectancy:	1.000.000 cycles				
Pressure rise rate:	≤14,500 psi/s (≤ 1.000 bar/s)				
Hysteresis:	10 ... 30 % (depending on type, non-adjustable)				
Vibration resistance:	10 g; 5 ... 200 Hz sine wave; DIN EN 60068-2-6				
Shock resistance:	294 m/s <sup>2</sup> ; 14 ms half sine wave; DIN EN 60068-2-27				
Cable length:	Standard length approx. 2m with wire end sleeve, also available in lengths of approx. 5m as well as customer-specific lengths				
Protection class:	IP65				
Cable cross-section:	3 x 0,75 mm <sup>2</sup>		3 x 0,5 mm <sup>2</sup>		
Housing material:	Aluminium		Zinc-plated steel (CrVI-free), anodised aluminium		
Weight:	approx. 380 g		approx. 230 g		

### Elektrische Werte

Rated working voltage $U_e$ (usage category)	Rated working current $I_e$ :	
250 VAC 50 / 60 Hz, AC 12	2 A	5 A
250 VAC 50 / 60 Hz, AC 14	1 A	1 A
24 VDC, DC 12 / DC 13	2 / 1 A	3,5 / 3,5 A
50 VDC, DC 12 / DC 13	1 / 0,5 A	2 / 1 A
75 VDC, DC 12 / DC 13	0,5 / 0,25 A	1 / 0,5 A
125 VDC, DC 12 / DC 13	0,2 / 0,1 A	0,3 / 0,2 A
250 VDC, DC 12 / DC 13	0,15 / 0,1 A	0,25 / 0,2 A
Rated insulation voltage $U_i$	300 V	
Rated impulse withstand voltage $U_{imp}$ :	4 kV	
Conventional thermal current $I_{the}$ :	5 A	
Switching overvoltage:	< 2,5 kV	
Rated frequency:	DC und 50 / 60 Hz	
Nominal current of short-circuit mechanism:	bis 3,5 A	
Conditional short-circuit current:	< 350 A	

# 0165

Diaphragm / piston pressure switches up to 250 V

ATEX 0102 CE II 2G Ex d II C T6 / T5 X (gas-protected zones 1 and 2)

- Aluminium housing
- Snap action with silver contacts
- Operating voltage up to 250 V
- Overpressure safety up to 2,900 / 8,700 psi (200 / 600 bar)<sup>1)</sup>

$P_{max.}$ in psi (bar)	Adjustment range in psi (bar)	Tolerance in psi (bar) at room temperature	Thread	Order number
----------------------------	----------------------------------	---	--------	--------------

## 0165 Diaphragm pressure switches

2,900 psi <sup>1)</sup> (200 bar <sup>1)</sup> )	14.5 - 87 psi (1 - 6 bar)	± 7.25 psi (± 0.5 bar)	1/4" BSPP female	0165 - 448 14 - 1 - 001
	72.5 - 725 psi (5 - 50 bar)	± 43.5 psi (± 3.0 bar)		0165 - 449 14 - 1 - 001

## 0165 Piston pressure switches

8,700 psi <sup>1)</sup> (600 bar <sup>1)</sup> )	290 - 1,450 psi (20 - 100 bar)	± 43.5 - 72.5 psi (± 3.0 - 5.0 bar)	1/4" BSPP female	0165 - 450 14 - X - 001
	362.5 - 3,625 psi (25 - 250 bar)	± 72.5 - 101.5 psi (± 5.0 - 7.0 bar)		0165 - 452 14 - X - 001
	1,450 - 5,800 psi (100 - 400 bar)	± 72.5 - 130.5 psi (± 5.0 - 9.0 bar)		0165 - 451 14 - X - 001

## Seal material – Application areas

NBR (BunaN)	Hydraulic/machine oil, heating oil, air, nitrogen, etc.	1
EPDM	Brake fluid, hydrogen, oxygen, acetylene, etc.	2
FKM (Viton®)	Hydraulic fluids (HFA, HFB, HFD), petrol/gasoline, etc.	3

Refer to page 82 for the temperature range and application thresholds of sealing materials

Your order number: 0165 - XXX 14 - X - 001

Piston pressure switches only have limited suitability for use with gases.

# M.8

ATEX



Contact assignment:

- 1 = white
- 2 = green
- 4 = brown

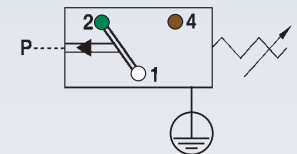

<sup>1)</sup> Static value. Dynamic value is 30-50 % lower. Values pertain to the hydraulic/pneumatic part of the pressure switch.

# M.8

ATEX

# 0340 / 0341

Diaphragm / piston pressure switches up to 250 V

ATEX CE II 3D IP65 T90°C (dust protection zone 22)

- Zinc-plated steel housing (CrVI-free), with anodised aluminium protective cap
- Snap action with silver contacts
- Operation voltage up to 250 V, protection class 2, protective insulation
- Overpressure safety up to 4,350 / 8,700 psi (300 / 600 bar)<sup>1)</sup>

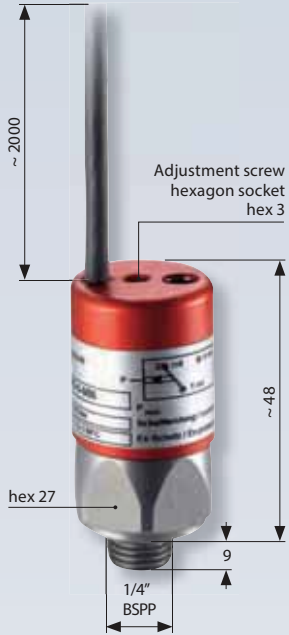

Contact assignment:

- 1 = black
- 2 = red
- 4 = white

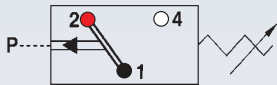

P <sub>max.</sub> in psi (bar)	Adjustment range in psi (bar)	Tolerance in psi (bar) at room temperature	Thread	Order number
-----------------------------------	----------------------------------	---	--------	--------------

### 0340 Diaphragm pressure switches

P <sub>max.</sub> in psi (bar)	Adjustment range in psi (bar)	Tolerance in psi (bar) at room temperature	Thread	Order number
4,350 psi <sup>1)</sup> (300 bar) <sup>1)</sup>	4.35 - 21.75 psi (0.3 - 1.5 bar)	± 2.90 psi (± 0.2 bar)	1/4" BSPP	0340 - 457 03 - X - 003
	14.5 - 145 psi (1 - 10 bar)	± 7.25 - 14.5 psi (± 0.5 - 1.0 bar)		0340 - 458 03 - X - 006
	145 - 290 psi (10 - 20 bar)	± 14.5 psi (± 1.0 bar)		0340 - 459 03 - X - 009
	290 - 725 psi (20 - 50 bar)	± 29 psi (± 2.0 bar)		0340 - 461 03 - X - 012

### 0341 Piston pressure switches

P <sub>max.</sub> in psi (bar)	Adjustment range in psi (bar)	Tolerance in psi (bar) at room temperature	Thread	Order number
8,700 psi <sup>1)</sup> (600 bar) <sup>1)</sup>	725 - 2,175 psi (50 - 150 bar)	± 72.5 psi (± 5.0 bar)	1/4" BSPP	0341 - 460 03 - X - 003

### Seal material – Application areas

Seal material	Application areas	Order number
NBR	Hydraulic/machine oil, air, nitrogen, etc.	1
EPDM	Brake fluid, water, hydrogen, oxygen, acetylene, etc.	2
FKM	Hydraulic fluids (HFA, HFB, HFD), petrol/gasoline, etc.	3
FFKM <sup>2)</sup>	Hot water, chemical acids, diluted alkalis, ketones, ester's, alcohols	6
HNBR	Hydraulic/machine oil, ester-based bio-oils	9

Refer to page 82 for the temperature range and application thresholds of sealing materials.



Article number: 034X - XXX 03 - X - XXX

Piston pressure switches only have limited suitability for use with gases (refer to Page 17 for explanations).



1) Static value. Dynamic value is 30-50 % lower. Values pertain to the hydraulic/pneumatic part of the pressure switch.  
2) Only suitable for diaphragm pressure switches (Type 0340).

# Vacuum switches

for negative pressure from 950 mbar to 100 mbar



- Switching point can be adjusted when fitted on site<sup>1)</sup>
- High overpressure resistance
- Long service life even under harsh conditions
- 0150 series available as changeover contacts up to 250 V
- 0151 series available as NC or NO up to 42 V

<sup>1)</sup> Pressure switches can also be supplied preset at factory.  
Our preset switches are sealed with lacquer paint, set points are embossed on the housing.

# Vacuum switches

## Technical data

M.9

Vacuum

Type:	<b>0150</b>	<b>0151</b>
Operating voltage:	10 ... 250 VAC/DC	10 ... 42 VAC/DC
Rated current (resistive load):	Refer to electrical values below	10 mA ... 4 A
Switching power:	Refer to electrical values below	100 VA
Temperature resistance of sealing materials:	-4 °F ... +212 °F (-20 °C ... +100 °C)	+5 °F ... +248 °F (-15 °C ... +120 °C)
Switching frequency:	200/min.	
Mechanical life expectancy:	1,000,000 cycles	
Pressure rise rate:	≤ 14.5 psi/ms (≤ 1 bar/ms)	
Vibration resistance:	10 g; 5 ... 200 Hz sine wave; DIN EN 60068-2-6	
Shock resistance:	294 m/s <sup>2</sup> ; 14 ms half sine wave; DIN EN 60068-2-27	
Housing material:	Aluminium	Brass
Protection class:	IP65 with socket device	IP65, terminals IP00
Weight:	approx. 9.5 oz (270 g)	approx. 5 oz (140 g)

### 0150 Electrical values (also refer to page 14 for technical explanations)

Rated working voltage $U_e$	Rated working current $I_e$ (usage category)
250 VAC 50 / 60 Hz	5 A (AC 12)
250 VAC 50 / 60 Hz	1 A (AC 14)
24 VDC	3.5 / 3.5 A (DC 12 / DC 13)
50 VDC	2 / 1 A (DC 12 / DC 13)
75 VDC	1 / 0.5 A (DC 12 / DC 13)
125 VDC	0.3 / 0.2 A (DC 12 / DC 13)
250 VDC	0.25 / 0.2 A (DC 12 / DC 13)
Rated insulation voltage $U_i$ :	300 V
Rated impulse withstand voltage $U_{imp}$ :	2.5 kV
Conventional thermal current $I_{the}$ :	6 A
Switching overvoltage:	< 2.5 kV
Rated frequency:	DC and 50 / 60 Hz
Nominal current of short-circuit mechanism:	up to 6.3 A
Conditional short-circuit current:	< 350 A
Tightening torque of terminal screws:	< 0.35 Nm
Connector cross-section:	0.5 ... 1.5 mm <sup>2</sup>

# M.9

Vacuum

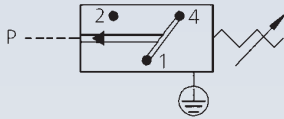

# 0150

Vacuum switch up to 250 V with snap action switch

- Aluminium housing
- Operating voltage up to 250 V
- Snap action with silver contacts
- Overpressure safety up to 290 psi (20 bar)<sup>1)</sup>
- Socket device similar to DIN EN 175301 (DIN 43650)
- Differential approx. 1.5" - 3" HG (50 - 150 mbar)(non-adjustable)

P <sub>max.</sub> in psi (bar)	Adjustment range in HG (mbar) (relative)	Tolerance in HG (mbar) at room temperature	Thread	Order number
-----------------------------------	---	---	--------	--------------

### 0150 Vacuum switch

290 psi <sup>1)</sup> (20 bar) <sup>1)</sup>	3" - 29" (100-950 mbar)	± 1.5" (± 50 mbar)	1/8" BSPP female	0150 - 456 15 - 4 - 001
---	----------------------------	-----------------------	------------------	-------------------------

### Seal material – Application areas

ECO	Air, oils, greases, fuel/gasoline	4
-----	-----------------------------------	---

Temperature resistance: - 4 °F... +212 °F (-20 °C... +100 °C)

**Your order number:** 0150 - 456 15 - 4 - 001

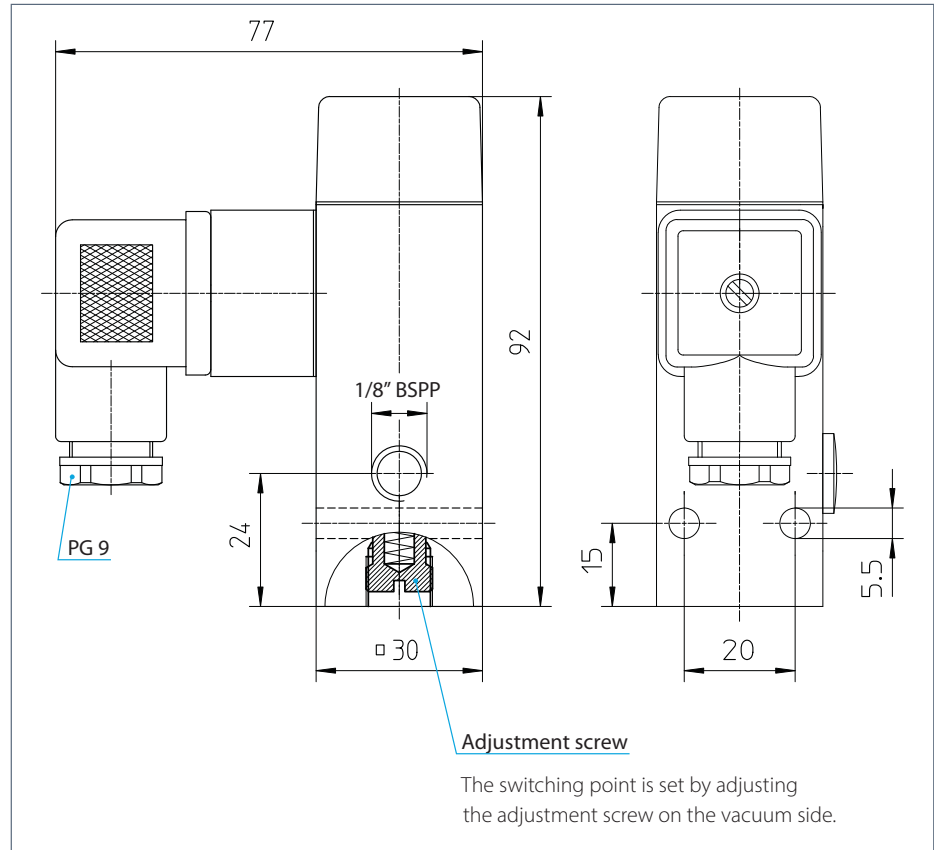

<sup>1)</sup> Static value. Dynamic value is 30-50% lower. Values pertain to the hydraulic/pneumatic part of the pressure switch.

# 0151

Vacuum switch up to 42 V, NO or NC

- Brass housing
- Spade or M3 screw terminal
- Operating voltage up to 42 V
- Overpressure safety up to 500 psi (35 bar)<sup>1)</sup>

P <sub>max.</sub> in psi (bar)	Adjustment range in HG (mbar) (relative)	Tolerance in HG (mbar) at room temperature	Thread	Order number
-----------------------------------	---	---	--------	--------------

### 0151 Vacuum switches with M3 screw terminal

500 psi <sup>1)</sup> (35 bar) <sup>1)</sup>	6" - 29" (200 - 950 mbar)	± 3" (± 100 mbar)	1/8" BSPP female	0151 - 452 15 - 3 - 001
---	------------------------------	----------------------	------------------	-------------------------

NO → |:

NC → :|

### 0151 Vacuum switches with spade terminal

500 psi <sup>1)</sup> (35 bar) <sup>1)</sup>	6" - 29" (200 - 950 mbar)	± 3" (± 100 mbar)	1/8" BSPP female	0151 - 454 15 - 3 - 001
---	------------------------------	----------------------	------------------	-------------------------

NO → |:

NC → :|

### Seal material – Application areas

FKM (Viton®)	Air, oils, greases, fuel/gasoline	3
--------------	-----------------------------------	---

Temperature resistance: +5 °F...+248 °F (-15 °C...+120 °C)

Your order number: 0151 - XXX 15 - 3 - 001

### Comparison of absolute/relative pressures

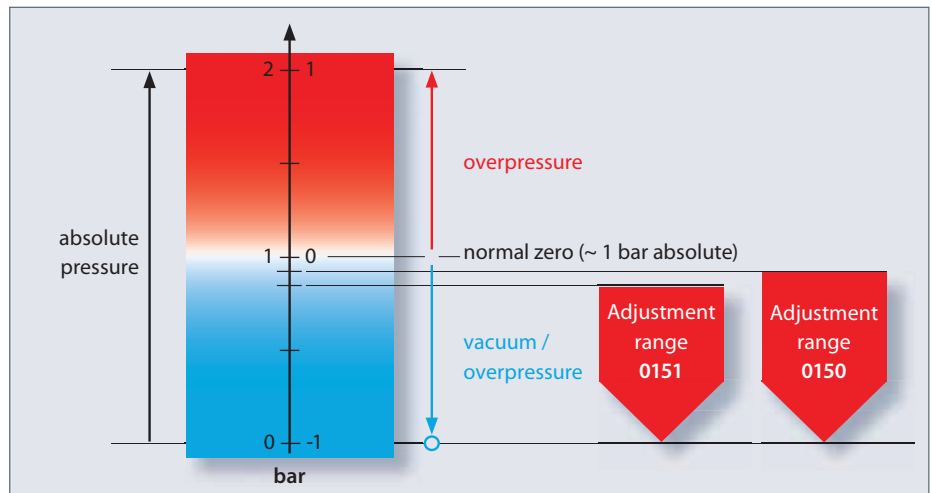

**Note:** Required set points in the vacuum range must be specified relative to atmospheric pressure (normal pressure) in the ordering process.

<sup>1)</sup> Static value. Dynamic value is 30-50 % lower. Values pertain to the hydraulic/pneumatic part of the pressure switch.

# M.9

Vacuum



Switches are also available on request with outer thread or integrated connector.





# Mating plugs

For pressure switches with integrated connector



M.10  
Accessories

<p><b>Deutsch DT06-2S (for DT04-2P)</b> 2 x 0,5 mm<sup>2</sup> Radox cable, IP65</p>	<p>suitable for series <b>0110 / 0111</b> <b>0410 / 0411</b></p>	<p>Article number: <b>1-1-10-653-118</b></p>	<p>1: white 2: black</p>	
<p><b>Deutsch DT06-3S (for DT04-3P)</b> 3 x 0,75 mm<sup>2</sup> PUR cable, IP67</p>	<p>suitable for series <b>0116 / 0117 / 0136 / 0137</b> <b>0416 / 0417</b></p>	<p>Article number: <b>1-1-36-653-160</b></p>	<p>A: brown B: blue C: black</p>	
<p><b>TE AMP Superseal 1.5<sup>®</sup>, 2-pin</b> 2 x 0,5 mm<sup>2</sup> Radox cable, IP65</p>	<p>suitable for series <b>0112 / 0113</b> <b>0412 / 0413</b></p>	<p>Article number: <b>1-1-12-653-113</b></p>	<p>1: white 2: black</p>	
<p><b>TE AMP Superseal 1.5<sup>®</sup>, 3-pin</b> 3 x 0,5 mm<sup>2</sup> Radox cable, IP65</p>	<p>suitable for series <b>0132 / 0133</b></p>	<p>Article number: <b>1-1-32-653-158</b></p>	<p>1: black 2: red 3: white</p>	
<p><b>TE AMP Junior Timer, 2-pin</b> 2 x 0,5 mm<sup>2</sup> Radox cable, IP65</p>	<p>suitable for series <b>0118 / 0119</b> <b>0418 / 0419</b></p>	<p>Article number: <b>1-1-18-653-116</b></p>	<p>1: black 2: white</p>	
<p><b>Packard MetriPack 280, 2-pin</b> 2 x 0,5 mm<sup>2</sup> Radox cable, IP65</p>	<p>suitable for series <b>0114 / 0115</b> <b>0414 / 0415</b></p>	<p>Article number: <b>1-1-14-653-114</b></p>	<p>A: black B: white</p>	
<p><b>Bayonet DIN 72585 A1-2.1</b> 2 x 0,5 mm<sup>2</sup> Radox cable, IP65</p>	<p>suitable for series <b>0120 / 0121</b></p>	<p>Article number: <b>1-1-20-653-112</b></p>	<p>1: black 2: white</p>	
<p><b>M 12x1 DIN EN 61076-2-101-LF, 4-pin</b> 4 x 0,34 mm<sup>2</sup> PUR cable, IP65</p>	<p>suitable for series <b>0122 / 0123 / 0124 / 0125</b> <b>0134 / 0135 / 0424 / 0425</b></p>	<p>Article number: <b>1-1-00-653-162</b></p>	<p>1: brown 3: blue 2: white 4: black</p>	

All mating plugs with 2 m cable

# Socket devices and protective caps

- IP65 socket devices or IP54 rubber protective caps for increased protection
- Simple installation with plug-in socket devices

			
<p><b>Rubber protective cap</b></p> <p>With central cable feed-through for 1.5 - 5 mm cable diameter</p> <p><b>With rubber protective cap fitted: IP54</b></p> <p>Suitable for voltages up to 42 V</p>	<p><b>Rubber protective cap</b></p> <p>With two cable feed-throughs for 1.7 - 2,2 mm cable diameter</p> <p><b>With rubber protective cap fitted: IP54</b></p> <p>Suitable for voltages up to 42 V</p>	<p><b>Rubber protective cap</b></p> <p>With two cable feed-throughs for 1.7 - 2,3 mm cable diameter</p> <p><b>With rubber protective cap fitted: IP54</b></p> <p>Suitable for voltages up to 42 V</p>	<p><b>Socket device</b></p> <p>cCSAus approval Housing: Polyamide PG9 screw fitting (tightening range 6 - 9 mm)</p> <p><b>With socket device fitted: IP65</b></p> <p>Suitable for voltages up to 250 V</p>
<p>suitable for series <b>0151 / 0163 / 0164 / 0166 0167 / 0168 / 0169</b></p>	<p>suitable for series <b>0151 / 0163 / 0164 / 0166 0167 / 0168 / 0169</b></p>	<p>suitable for series <b>0170 / 0171 / 0180* / 0181* / 0183* / 0186* / 0187* 0190 / 0191 / 0196 / 0197</b> (*up to 42 V)</p>	<p>suitable for series <b>0170 / 0171 / 0180 / 0181 0183 / 0186 / 0187 0190 / 0191 / 0196 / 0197</b></p>
<p>Article number: <b>1-1-66-621-010</b></p>	<p>Article number: <b>1-1-66-621-003</b></p>	<p>Article number: <b>1-1-70-621-007</b></p>	<p>Article number: <b>1-1-80-652-002</b></p>

<p><b>Socket device</b></p> <p>to DIN EN 175301-803-A (DIN 43650)</p> <p>PG9 screw fitting (tightening range 6 – 9 mm) terminals for wire cross-sections: 0.34 ... 1.5 mm<sup>2</sup> (AWG 22 ... AWG 16), tightening torque for terminal screw 0.4 Nm</p> <p><b>With socket device fitted: IP65</b></p> <p>Suitable for voltages up to 250 V</p>	<p><b>Socket device</b></p> <p>With indicator lamp to DIN EN 175301-803-A (DIN 43650)</p> <p>PG9 screw fitting (tightening range 6 – 9 mm) terminals for wire cross-sections: 0.34 ... 1.5 mm<sup>2</sup> (AWG 22 ... AWG 16), tightening torque for terminal screw 0.4 Nm</p> <p><b>With socket device fitted: IP65</b></p> <p>Suitable for voltages up to 24 or 250 V</p>	<p><b>Socket device</b></p> <p>M 12x1 DIN EN 61076-2-101 A straight, 4-pin</p> <p>Terminals for wire cross-section 0.75 mm<sup>2</sup> (AWG 18), tightening torque for terminal screw 0.4 Nm</p> <p><b>With socket device fitted: IP65</b></p> <p>Suitable for voltages up to 48 V</p>	<p><b>Socket device</b></p> <p>M 12x1 DIN EN 61076-2-101 A angled, 4-pin</p> <p>Terminals for wire cross-section 0.75 mm<sup>2</sup> (AWG 18), tightening torque for terminal screw 0.4 Nm</p> <p><b>With socket device fitted: IP65</b></p> <p>Suitable for voltages up to 48 V</p>
<p>suitable for series <b>0150 / 0161 / 0162 / 0175</b> <b>0184 / 0185 / 0194 / 0195</b></p>	<p>suitable for series <b>0150 / 0161 / 0162 / 0175</b> <b>0184 / 0185 / 0194 / 0195</b></p>	<p>suitable for series <b>0122 / 0123 / 0124 / 0125</b> <b>0134 / 0135 / 0424 / 0425</b></p> <p>and for all transmitters and electronic pressure switches with an M12 connector</p>	<p>suitable for series <b>0122 / 0123 / 0124 / 0125</b> <b>0134 / 0135 / 0424 / 0425</b></p> <p>and for all transmitters and electronic pressure switches with an M12 connector</p>
<p>Article number: <b>1-1-84-652-009</b></p>	<p>Article number: for 24 VDC: <b>1-1-84-652-011</b> for 250 VAC: <b>1-1-84-652-010</b></p>	<p>Article number: <b>1-6-00-652-016</b></p>	<p>Article number: <b>1-6-00-652-017</b></p>

# Thread adapters

For requirements at short notice and for realising custom solutions

- The materials and shapes of thread adapters are aligned perfectly to our switches and transmitters
- Thread adapters are supplied with seals



**For G 1/8 female**

Vacuum switch  
with thread code 15



**For G1/4 DIN EN ISO 1179-1 (DIN 3852-E)**

All pressure switches and transmitters  
with thread code 41

Dual nipple brass		Thread adapters stainless steel (1.4305 / AISI 303)			
<b>G 1/8 shape E</b> DIN EN ISO 1179-2 includes sealing ring NBR	<b>G 1/8 shape A</b> DIN ISO 16030 includes sealing ring stainless steel / NBR	<b>G 1/4</b> DIN EN ISO 1179-1 (DIN 3852-E) female thread			
					
<b>NPT 1/8-27</b>	<b>NPT 1/4-18</b>	<b>M10 x 1 shape A</b> DIN 3852-1	<b>M14 x 1.5 shape E</b> DIN 3852-E includes sealing ring FKM	<b>NPT 1/4-18</b>	<b>9/16 -18UNF</b> includes O-ring FKM
hex 15 h = 25 mm	hex 24 h = 28 mm	hex 22 h = 30,5 mm	hex 22 h = 35 mm	hex 22 h = 35,5 mm	hex 22 h = 33 mm
Article number:	Article number:	Article number:	Article number:	Article number:	Article number:
<b>1-1-00-420-014</b>	<b>1-1-00-420-029</b>	<b>1-1-00-420-020</b>	<b>1-1-00-420-028</b>	<b>1-1-00-420-021</b>	<b>1-1-00-420-027</b>

# M.10

Accessories



**For G 1/4**

All hex 24 and hex 27 pressure switches with thread code 03



**For M14x1.5 ISO 6149-3**

Pressure switch series 0183 with thread code 45



**For G 1/4**

All hex 24 and hex 27 pressure switches with thread code 03

Thread adapters zinc-plated steel (CrVI-free)				
<b>G 1/4</b> female thread includes sealing ring FKM		<b>M14 x 1.5</b> DIN EN ISO 6149-1 female thread		
				
<b>R 1/4</b>	<b>3/8-24 UNF-2A</b>	<b>G 1/4</b>	<b>M12 x 1.5</b>	<b>NPT 1/8-27</b>
hex 24 h = 30 mm	hex 24 h = 26 mm	hex 24 h = 26 mm	hex 24 h = 26 mm	hex 24 h = 26 mm
Article number:	Article number:	Article number:	Article number:	Article number:
<b>1-1-00-420-009</b>	<b>1-1-00-420-013</b>	<b>1-1-83-420-006</b>	<b>1-1-83-420-007</b>	<b>1-1-83-420-008</b>

Adapter Aluminium
<b>G 1/4</b> female thread includes copper sealing ring

<b>Block style</b> includes NBR O-ring
35 A/F h = 22 mm
Article number:
<b>1-1-00-420-025</b>



# E. Electronic Pressure Switches

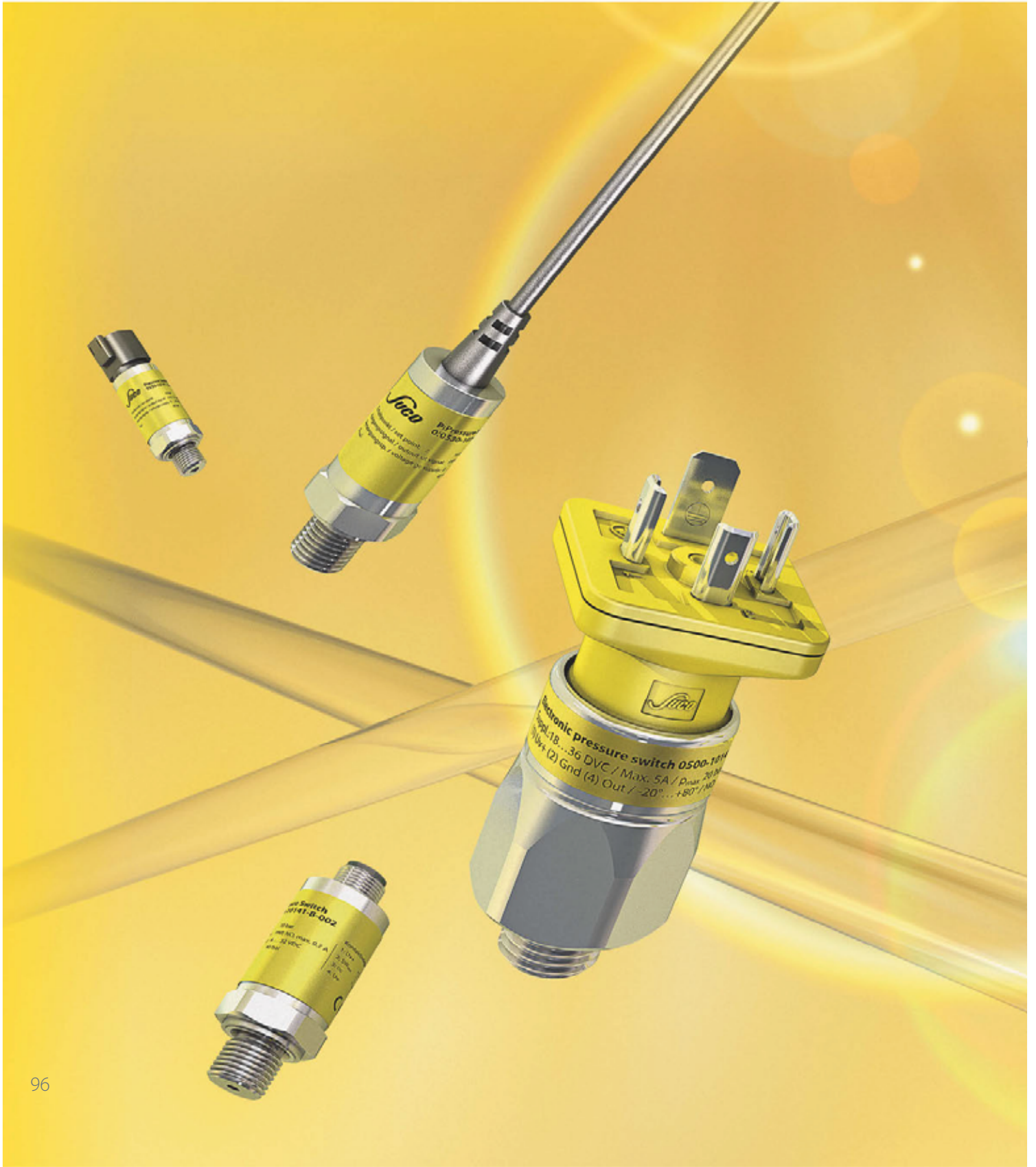

E.4 Menu-controlled electronic pressure switches with display from page 118

**Special feature:** All functions programmable from menu  
Switching state LEDs, display, coding, etc.

Switching point: 0 – 400 bar (0-5,800 psi)  
Overpressure protection: Up to 2 x  
Transistor outputs: Qty: 2, output current: max. 1.4 A  
Variant: PNP  
**Additional analogue output:** 4 – 20 mA  
Housing materials: Anodised aluminium and die-casted zinc  
Sealing materials: NBR, FKM  
Thread: Female thread  
Type: 0570



### Electronic pressure switches with SoS technology



E.5 Electronic pressure switches, High-Performance series, hex 22 with 1 switching output from page 122

**Special feature:** Highest accuracy and long-term stability  
Switching point: 0 – 600 bar (0-8,700 psi)  
Overpressure protection: Up to 4 x  
Transistor outputs: Qty: 1, maximum output current 0.5 A  
Variants: PNP or NPN  
Housing materials: Stainless steel 1.4305 (AISI 303)  
Sealing materials: All welded, without elastomer seal  
Threads: Different male threads  
Types: 0530, 0531, 0532, 0533



E.6 Electronic pressure switches, High-Performance series, hex 22 with 2 switching outputs from page 126

**Special feature:** Highest accuracy and long-term stability  
Switching point: 0 – 600 bar (0-8,700 psi)  
Overpressure protection: Up to 4 x  
Transistor outputs: Qty: 2, maximum output current 0.5 A  
Variants: PNP or NPN  
Housing materials: Stainless steel 1.4305 (AISI 303)  
Sealing materials: All welded, without elastomer seal  
Threads: Different male threads  
Types: 0540, 0541, 0542, 0544, 0545, 0546



E.7 Accessories from page 130

- Mating plugs
- Thread adapters
- Programming device PPD05



E.4 Menu-controlled electronic pressure switches with display from page 118

**Special feature:** All functions programmable from menu  
Switching state LEDs, display, coding, etc.

Switching point: 0 – 400 bar (0-5,800 psi)  
Overpressure protection: Up to 2 x  
Transistor outputs: Qty: 2, output current: max. 1.4 A  
Variant: PNP  
**Additional analogue output:** 4 – 20 mA  
Housing materials: Anodised aluminium and die-casted zinc  
Sealing materials: NBR, FKM  
Thread: Female thread  
Type: 0570



### Electronic pressure switches with SoS technology



E.5 Electronic pressure switches, High-Performance series, hex 22 with 1 switching output from page 122

**Special feature:** Highest accuracy and long-term stability  
Switching point: 0 – 600 bar (0-8,700 psi)  
Overpressure protection: Up to 4 x  
Transistor outputs: Qty: 1, maximum output current 0.5 A  
Variants: PNP or NPN  
Housing materials: Stainless steel 1.4305 (AISI 303)  
Sealing materials: All welded, without elastomer seal  
Threads: Different male threads  
Types: 0530, 0531, 0532, 0533



E.6 Electronic pressure switches, High-Performance series, hex 22 with 2 switching outputs from page 126

**Special feature:** Highest accuracy and long-term stability  
Switching point: 0 – 600 bar (0-8,700 psi)  
Overpressure protection: Up to 4 x  
Transistor outputs: Qty: 2, maximum output current 0.5 A  
Variants: PNP or NPN  
Housing materials: Stainless steel 1.4305 (AISI 303)  
Sealing materials: All welded, without elastomer seal  
Threads: Different male threads  
Types: 0540, 0541, 0542, 0544, 0545, 0546



E.7 Accessories from page 130

- Mating plugs
- Thread adapters
- Programming device PPD05



# Technical explanations for electronic pressure switches

## What is an electronic pressure switch?

An electronic pressure switch converts the medium pressure which is present at the measuring cell into a digital, electrical switch signal (ON / OFF).

An electronic pressure switch is more complex than a mechanical pressure switch, and thus generally more expensive. As an electronic pressure switch has no moving parts (relative to each other), it usually has a much prolonged service life and provides a higher level of precision (depending on application).

The hysteresis can be set over a wide range and virtually independently of the switching point. Electronic pressure switches can also be equipped with additional functions, such as optical displays and menu control.

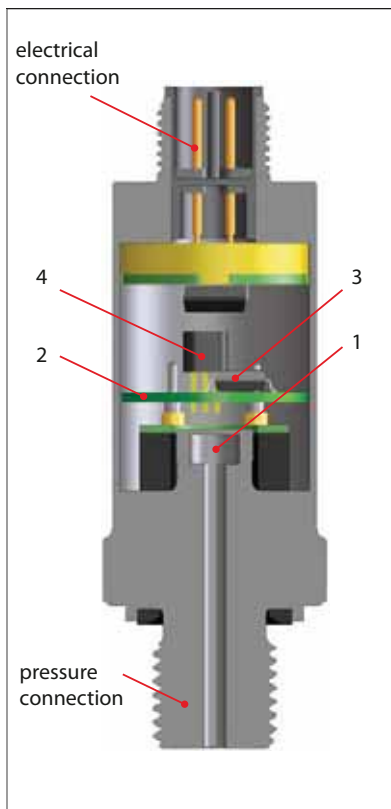

## How does an electronic pressure switch work?

The pressure measuring cell fitted (1) has a membrane that is exposed to the pressure to be measured. Affixed to this membrane is a bridge circuit consisting of four ohmic resistors in the form of a Wheatstone bridge. The values of these resistors change proportionally to the pressure load present at the measuring cell or membrane. The bridge voltage of the measuring cell is amplified in the evaluation electronics (2) and processed digitally by a microcontroller (3).

Once the switching point or switch-back point is reached, the output transistor (4) closes or opens depending on the output function (normally open / closed contact).

## SoS technology

In the silicone-on-sapphire technology, the substrate of the thin film measuring cell is synthetic sapphire. This has excellent mechanical and temperature stable properties and prevents undesired parasitic effects, thereby having a positive effect on accuracy and stability. In conjunction with a titanium membrane, this results in virtually unique coaction between the temperature coefficients of sapphire and titanium.

This is because, unlike silicon and stainless steel, they are more closely matched and thus require only a low level of compensation. This also has a favourable effect on longterm stability.

## „Oil-filled“ stainless steel measuring cell

In this measuring cell technology, the piezo-resistive measuring cell is packaged within a metallic housing filled with fluorine oil. This means the measuring cell is virtually free of external mechanical stress. Fluorine oil has excellent characteristics in regards to temperature and ageing behaviour, and is not flammable and so fits perfectly for oxygen applications. It is not recommended for food applications.

## Ceramic measuring cell / thick film technology

Ceramic thick film pressure measuring cells are made up of a sintered ceramic body. The ceramic body sleeve already has the key geometries for the subsequent pressure range. The membrane thickness required and thus, the pressure range required is established with grinding and lapping. The resistors are imprinted with thick film technology and interconnect to form a measuring bridge.

Block diagram

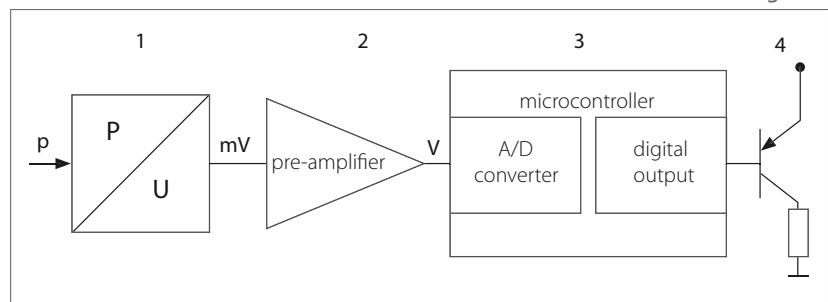

**Adjustment range of switching point**

The pressure range within which the switching point of an electronic pressure switch can be set is called adjustment range. The switching point corresponds to the pressure value at which the electric circuit of the output is opened or closed.

**Switching point accuracy and tolerances**

The switching point accuracy of electronic pressure switches is specified by SUCO and relates to the full scale value (FS). The switching point tolerances specified by us are valid at room temperature (RT) and new state. The values can change as a result of temperature, ageing and application specific conditions. Switching points can either be set at the factory or by the customer on site (depending on model).

**Hysteresis Rising/falling switching point**

The difference between the rising (upper) and falling (lower) switching points (refer to the figure) is known as hysteresis (switchback difference).

Our electronic pressure switches are a perfect fit to extremely low or high hysteresis.

Hysteresis is either set at the factory or by the customer on site (only the 0570 series). The hysteresis or switch-back point of all pressure switches can be set over almost the entire adjustment range.

Please ask about the possible setting ranges you may require.

**The hysteresis specified in the data sheet is set if nothing is specified in the order.**

**Window function**

In the window function, the switch signal is programmed such that it remains ON or OFF between two values. This means a defined pressure range can be monitored. This function is only possible on the 053X series.

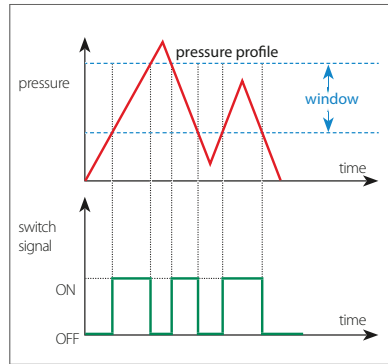

**Switching delay**

Switch outputs can be programmed with a delay separately for switch-on and switch-off (depending on model). Delays of up to several seconds are possible.

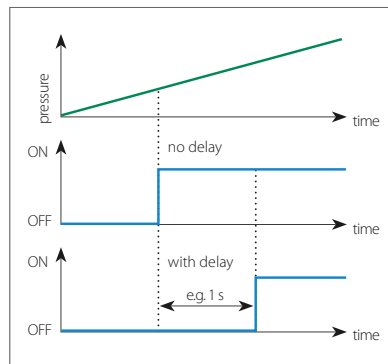

**Hysteresis**

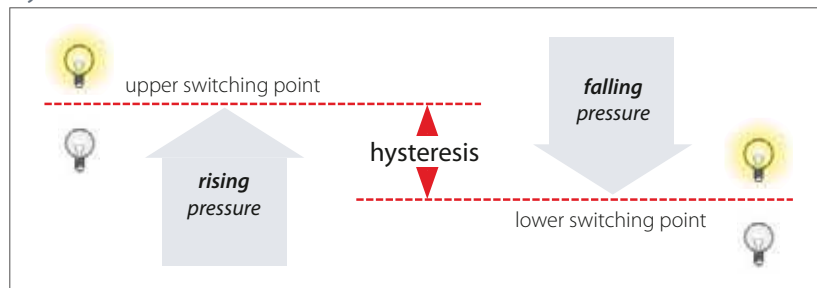

**Operating/supply voltage**

All electronic pressure switches work with DC voltage and have no galvanic isolation. Within the thresholds specified in the relevant data sheet, the supply voltage may change without influencing the output signal. In order to guarantee the functionality of an electronic pressure switch, the minimum operating voltage must be respected. The maximum operating voltage may not be exceeded to avoid damage on the electronics.

**Output current**

Depending on the model, electronic pressure switches have a maximum output current of 0.5 A to 1.4 A and therefore are also suitable for applications requiring relatively high control and switching currents.

**Load**

The output transistor is an open collector, i.e. the output must be wired with a load. The load limits the switching current and is selected according to the application.

Electronic pressure switches have protection from voltage peaks at the output, and are short-circuit proof. When inductive loads are switched (relays, motors, etc.), provision may have to be made for an additional electronic snubber to eliminate high voltage peaks. This is realised e.g. with flyback diodes, or even better with suppressor diodes or varistors.



# Technical explanations for electronic pressure switches

## Connection types and output functions

There are essentially two different ways to connect the load or apparent ohmic resistance to electronic pressure switches:

### PNP output / high-side / plus-switching

PNP output (plus-switching) is the most popular variant in Europe. Here the load is connected to the output of the switch and ground (GND as reference potential).

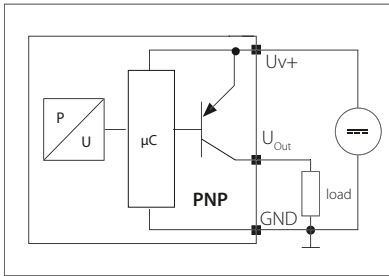

### NPN output / low-side / minus-switching

For an NPN output (minus-switching), the load is connected to the switching output and to the positive line of the supply voltage (Uv+ as reference potential).

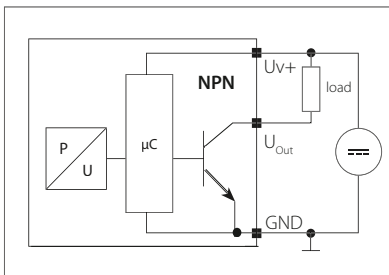

### NO / NC

Electronic pressure switches are available as normally open (NO) or normally closed (NC) versions. Also refer to section M.0, page 14.

## Temperature errors and ranges

The temperature (both of the medium and environment) generally has a significant influence on the accuracy of an electronic pressure switch. Electronic pressure switches are temperature compensated over a particular range corresponding to the typical application. This means that temperature errors within this temperature range are minimised by means of circuitry design and algorithms. The temperature error is added to the accuracy, and shown in the total error band of the electronic pressure switch, also called „butterfly graph“. Outside the compensated temperature range, the maximum error is not defined, however the electronic pressure switch still functions. To prevent mechanical and electrical damage, electronic pressure switches may not be used beyond the threshold temperature ranges specified in the data sheet.

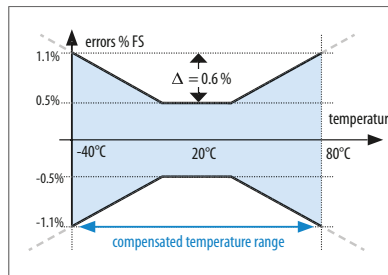

## Service life and long-term stability

Service life information pertains to nominal conditions specified in the data sheet, and can vary considerably when a product is operated mechanically or electrically outside the specifications. Service life essentially depends on the used measuring cell technology.

Ageing is accelerated (or slowed) due to different factors - such as temperature, temperature change and reduction of mechanical forces. The occurrence of ageing does effect the total accuracy.

SUCO specifies long-term stability in accordance with DIN 16086 in relation to one year. Typically the influence of aging on the accuracy reduces with increasing operating duration. The information in the data sheet corresponds to the worst case scenario.

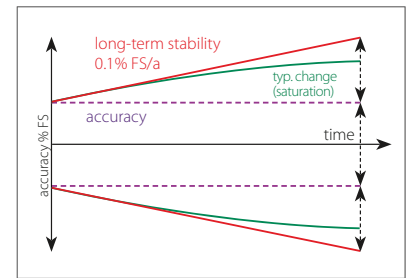

## Resolution

The A/D resolution (analogue - digital) of an electronic pressure switch defines the smallest change of the analogue - digital - analogue conversion which takes place by the signal processing of an electronic pressure switch. If for example 13-bit resolution is used for an electronic pressure switch with a 100 bar setting range, the smallest signal change is 8192 steps ( $2^{13}$ ). As state of the art a resolution of 12 bits and hence 4096 steps ( $2^{12}$ ) is typical. Therefore pressure changes of 100 bar / 4096 = 0.024 bar can be recorded.

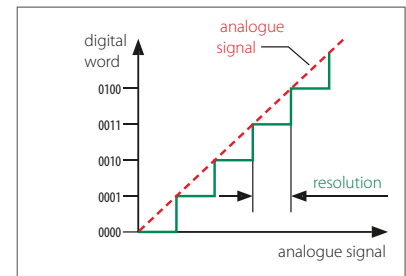

### Sampling rate

The sampling rate (or sampling frequency) defines the number of samples per time unit (typically in seconds or milliseconds) taken from an analogue signal and converted to a digital signal. The sampling rate is an indicator of how fast the output signal of an electronic pressure switch responds to the pressure change at the input.

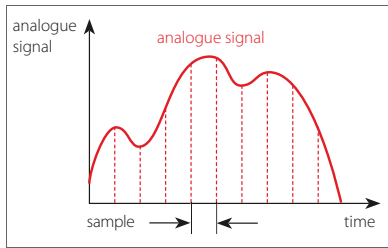

### Response time

The response or circuit time is shorter than 2 to 4 milliseconds (depending on model). The sum of A/D and D/A conversions, and the analogue and digital filters in the signal chain from the measuring bridge to the output, make up the response time. Filtering is used to suppress unwanted pressure peaks and electrical interference signals and to ensure good EMC characteristics.

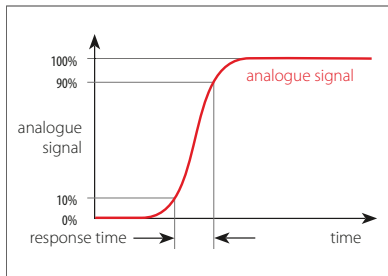

### CE mark

Electronic pressure switches from SUCO fall under the 2014/30/EU EMC Directive. EC declarations of conformity have been issued for the electronic pressure switches are available on request or can be downloaded from our website. The relevant devices are denoted by a CE mark in our catalogue.

The Machinery Directive 2006/42/EC is not applicable, because our products are classed as components.

Our products are designed for Group 2 fluids based upon good engineering practise in line with Pressure Equipment Directive 2014/68/EU, meaning neither a declaration of conformation may be issued nor a CE mark affixed.

### Electromagnetic compatibility (EMC)

Electronic pressure switches from SUCO do comply to all important industrial EMC standards. The basis for the standards are the stricter thresholds for transient emissions in residential environments (EN 61000-6-3) and immunity for industrial environments (EN 61000-6-2).

Generic standard	Test standard	Parameter(s)
Radio disturbance and immunity	EN 55016-2-1 EN 55016-2-3	60 dBuV
Radiated, high-frequency electromagnetic field immunity test	EN 61000-4-3	10 V/m; 80-1000 MHz, 3 V/m; 1400-2000 MHz, 1 V/m; 2000-2700 MHz
Immunity to conducted disturbances, induced by radio-frequency fields	EN 61000-4-6	10 V; 0,15-80 MHz
Electrical fast transient / burst immunity test	EN 61000-4-4	±2 kV
Surge immunity test	EN 61000-4-5	±0.5 kV (common) ±0.5 kV (differential)
Electrostatic discharge (ESD) immunity test	EN 61000-4-2	air: 8 kV with contact: 4 kV



# Technical explanations for electronic pressure switches

## Conversion chart for pressure units

Abbreviation for unit	Name of unit	Pa = N/m <sup>2</sup>	bar	Torr	lbf/in <sup>2</sup> , PSI
1 Pa = N/m <sup>2</sup>	Pascal	1	0.00001	0.0075	0.00014
1 bar	Bar	100 000	1	750.062	14.5
1 Torr = 1 mmHg	Millimeters of mercury	133.322	0.00133	1	0.01934
1 lbf/in <sup>2</sup> = 1 PSI	Pound-force per square inch	6894	0.06894	51.71	1

## Conversion chart for temperature units

	K	°C	F
K	1	K - 273.15	9/5 K - 459.67
°C	°C + 273.15	1	9/5 °C + 32
F	5/9 (F + 459.67)	5/9 (F - 32)	1

### Insulation strength

According to the latest specifications for immunity to surges and lightning protection, the following must be taken into account when testing insulation strength: With insulation test devices having an inner resistance exceeding 42 Ohm, the insulation strength of electronic pressure switches can be tested up to 500 VDC.

All contacts must be tested short-circuited against the housing. For a specific threshold value of test voltage, the protective circuit for surge protection is activated without any defects arising within the circuit.

In the process, the current may rise to a point at which an insulation strength fault is indicated. The recommendation therefore is to conduct the insulation test of the electronic pressure switch when it is removed, or independently of the overall system.

### Medium compatibility

The specifications on medium compatibility in this catalogue pertain to the specific seal and housing materials as well as the used measuring cell technology and so cannot be generalised.

### Titanium

Its high levels of mechanical resistance and the wide media compatibility – in particular to corrosive media – do make titanium the ideal material for measuring cells and membranes. It is not recommended for oxygen or hydrogen applications.

### Stainless steel (1.4305 / AISI 303)

Stainless steel with broad level of media compatibility. Also suitable for oxygen and hydrogen applications.

### Stainless steel (1.4404 / AISI 316L)

Stainless steel with broad level of media compatibility. Also suitable for chemical industry and sea water applications.

### Oxygen and hydrogen

It is recommended to use an EPDM seal for the media oxygen / hydrogen to be monitored. The EPDM seal of the „Performance“ series (pp. 106-113) was successfully tested at the BAM (Federal Institute for Materials Testing) up to 250 bar by means of an oxygen pressure shock test at 60 °C.

EPDM must not come into contact with oil, as this results in swelling and softening of the material and thus the failure of the electronic pressure switch.

Country-specific safety requirements and application guidelines must be observed if the medium to be monitored is oxygen or hydrogen, such as DGUV accident prevention regulations (DGUV 500, Section 2.32 and BGI 617).

**Please specify when ordering „for oxygen, oil and grease-free“ or order plasma cleaned and individually packaged electronic pressure switches (see also „Plasma cleaning for oxygen applications / LABS-free (PWIS-free)“ on page 9).**

### Pressure peak dampening

If required, our electronic pressure switches can also be fitted with a pressure snubber (pressure peak orifice) to protect the measuring cell against transient pressure loads such as pressure peaks due to the switching of valves, cavitation effects, etc. which can shorten life expectancy.

For liquid media, the hole of a pressure snubber cannot be chosen to be any small size. At low temperatures the viscosity of the media will increase. In a case of dropping pressure the media might remain in the cavity behind the snubber which might affect the functionality of the electronic pressure switch. Thus a bore diameter of 0.8 mm has been established.

### Product information

The technical information in this catalogue is based upon fundamental testing during product development, as well as upon empirical values. The information cannot be used for all application scenarios.

**Testing of the suitability of our products for a specific application (e.g. also the checking of material compatibilities) falls under the responsibility of the user. It may be the case that suitability can only be guaranteed with appropriate field testing.**

**Subject to technical changes.**

# Selection matrix for electronic pressure switches

Type / series		0500	0501	0510	0511	0520	0570	0530	0531	0532	0533	0540	0541	0542	0544	0545	0546	
Page		109	109	113	113	117	120	125	125	125	125	129	129	129	129	129	129	
Technology	ceramic / thick-film	■	■	■	■	■	■											
	Measuring cell	titanium / SoS						■	■	■	■	■	■	■	■	■	■	■
Variants	NO	■		■		■	■	■		■		■		■	■		■	
	NC		■		■				■		■		■	■			■	
	1 switching output	■	■	■	■	■		■	■	■	■							
	2 switching outputs						■					■	■	■	■	■	■	
	PNP (High Side)	■	■	■	■	■	■	■	■				■	■	■		■	
	NPN (Low Side)									■	■					■	■	■
	analogue output 4 - 20 mA						■											
Supply voltage	9.6 – 32 V	■	■	■	■			■	■	■	■	■	■	■	■	■	■	
	12–30V						■											
	15–36V					■												
Adjustment range	0 – 2 bar (0-29 psi)	■	■	■	■													
	0 – 4 bar (0-58 psi)	■	■	■	■													
	0 – 10 bar (0-145 psi)	■	■	■	■	■	■	■	■	■	■	■	■	■	■	■	■	
	0 – 16 bar (0-232 psi)	■	■	■	■			■	■	■	■	■	■	■	■	■	■	
	0 – 25 bar (0-362 psi)							■	■	■	■	■	■	■	■	■	■	
	0 – 40 bar (0-580 psi)	■	■	■	■													
	0 – 100 bar (0-1,450 psi)	■	■	■	■	■	■	■	■	■	■	■	■	■	■	■	■	
	0 – 250 bar (0-3,626 psi)	■	■	■	■	■		■	■	■	■	■	■	■	■	■	■	
	0 – 400 bar (0-5,800 psi)						■	■	■	■	■	■	■	■	■	■	■	
	0 – 600 bar (0-8,700 psi)							■	■	■	■	■	■	■	■	■	■	
Switch point adjustability	at factory	■	■	■	■	■	■	■	■	■	■	■	■	■	■	■	■	
	by customer (on site)			■	■	■	■											
Hysteresis adjustability	at factory	■	■	■	■	■	■	■	■	■	■	■	■	■	■	■	■	
	by customer (on site)						■											
	window mode (settable at factory)	■	■	■	■			■	■	■	■							
Max. over-pressure	up to 2x	■	■	■	■	■	■											
	up to 4x							■	■	■	■	■	■	■	■	■	■	
Size	hex 22							■	■	■	■	■	■	■	■	■	■	
	hex 24	■	■	■	■													
	A/F 30					■												
	A/F 32						■											
Housing material	zinc-plated steel					■												
	stainless steel 1.4305 / AISI 303	■	■	■	■			■	■	■	■	■	■	■	■	■	■	
	aluminium / die-casted zinc						■											
Additional functions	7-segment and menu control						■											
	LED switching state indicator	■	■	■	■		■	■	■	■	■	■	■	■	■	■	■	
	Programmable via PPD05	■	■															
Option	suitable for oxygen (on request)	■	■	■	■													

■ M12x1 DIN EN 61076-2 101 A connector only



## E.1

hex 24

Performance

adjustable at factory

# Electronic pressure switches, Performance series

adjustable at factory or programmable with programming device PPD05



- Very attractively priced electronic pressure switches, particularly for high volume deployment
- High overpressure protection (up to 2 x)
- Small, compact electronic switches with ceramic sensor
- Hysteresis adjustable within a wide range (2 % – 98 %, set at factory)
- Programming of switching points and switching delay time possible via PPD05 (see Chapter E.7, page 133)
- Monitoring of a pressure range due to window function
- High level of adaptability to your requirements (custom solutions)
- Available as 'plasma cleaned for oxygen applications'<sup>1)</sup>

# Electronic pressure switches, Performance series

## Technical details

	<b>0500 NO</b> <b>0501 NC</b>						
Transistor output:	PNP output (High-Side N-channel)						
Supply voltage:	9.6 – 32 VDC with reverse voltage protection						
Output current:	0.5 A with ( $\leq 0.2$ A at $\geq 50$ °C) short-circuit and overvoltage protection						
Idle power consumption:	< 30 mA						
Adjustment range $p_{nom}$ :	0 - 2 bar (0 - 29 psi)	0 - 4 bar (0 - 58 psi)	0 - 10 bar (0 - 145 psi)	0 - 16 bar (0 - 232 psi)	0 - 40 bar (0 - 580 psi)	0 - 100 bar (0 - 1,450 psi)	0 - 250 bar (0 - 3,625 psi)
Max. overpressure: <sup>1)</sup>	4 bar (58 psi)	10 bar (145 psi)	20 bar (290 psi)	40 bar (580 psi)	100 bar (1,450 psi)	150 bar (2,175 psi)	375 bar (5,439 psi)
Burst pressure: <sup>1)</sup>	8 bar (116 psi)	20 bar (290 psi)	35 bar (507 psi)	60 bar (870 psi)	140 bar (2,030 psi)	300 bar (4,350 psi)	500 bar (7,252 psi)
Mechanical life expectancy:	5,000,000 switching cycles at rise rates to 1,000 bar/s at $p_{nom}$						
Pressure rise rate:	1,450 psi (1,000 bar/s)						
Accuracy:	$\pm 0.5$ % of adjustment range $p_{nom}$ (full scale (FS)) at room temperature						
Switching point adjustment range:	3 ... 100 % of adjustment range $p_{nom}$ (FS), set at factory						
Hysteresis: <sup>2)</sup>	2 ... 98 % FS, programmable at factory (max. tolerance $\pm 1.0$ % of adjustment range $p_{nom}$ )						
Default-Hysteresis without order specification	2 bar (29 psi)	4 bar (58 psi)	10 bar (145 psi)	16 bar (232 psi)	40 bar (580 psi)	100 bar (1,450 psi)	250 bar (3,625 psi)
	0.1 bar (1.5 psi)	0.2 bar (3 psi)	0.5 bar (7 psi)	0.8 bar (12 psi)	2 bar (29 psi)	5 bar (72.5 psi)	10 bar (145 psi)
Operating mode:	with hysteresis or window function (see page 101), programmable at factory						
Resolution:	0.2 % of adjustment range $p_{nom}$ (FS)						
Long term stability:	$\pm 0.1$ % of adjustment range $p_{nom}$ (FS) per year						
Repeatability: <sup>3)</sup>	$\pm 0.1$ % of adjustment range $p_{nom}$ (FS)						
Switching time:	< 4 ms						
Switch-on / - off delay:	Adjustable between 0 and 2 s (please specify when ordering, otherwise default 0 s is set)						
Temperature error: <sup>3)</sup>	$\pm 0.04$ % of adjustment range $p_{nom}$ (FS) / °C						
Compensated temperature range:	0 °C ... +70 °C (+32 °F ... +158 °F), total error $\leq 2$ %						
Temperature range ambient:	-30 °C ... +100 °C (-22 °F ... +212 °F)						
Temperature range media:	with TPE seal: -22 °F ... +230 °F (-30 °C ... +110 °C)						
	with NBR seal: -22 °F ... +212 °F (-30 °C ... +100 °C)						
	with EPDM seal: -22 °F ... +257 °F (-30 °C ... +125 °C)						
	with FKM seal: <sup>4)</sup> -4 °F ... +257 °F (-20 °C ... +125 °C)						
Wetted parts material	Housing:	Stainless steel (1.4305 / AISI 303)					
	Messuring cell:	Ceramic					
	Seal material:	TPE, NBR, EPDM or FKM <sup>4)</sup>					
Insulation resistance:	> 100 M $\Omega$ (35 VDC)						
Vibration resistance:	20 g; at 4...2000 Hz sine wave, DIN EN 60068-2-6						
Shock resistance:	500 m/s <sup>2</sup> , 11 ms half sine wave; DIN EN 60068-2-27						
Protection class:	IP65: DIN EN 175301-803-A IP67: M12x1, AMP-Superseal®, cable connector IP67 and IP6K9K: Bayonet ISO 15170-A1-4.1, Deutsch DT04-3P						
Electromagnetic compatibility:	EMV 2014/30/EU, EN 61000-6-2:2005, EN 61000-6-3:2007						
Cable output thread size:	For DIN EN 175301: PG9 (outside diameter of cable 6 to 9 mm)						
Weight:	approx. 80 g (DIN EN 175301 approx. 110 g)						

<sup>1)</sup> Static pressure, dynamic pressure 30 to 50 % lower. Values refer to the hydraulic or pneumatic part of the electronic pressure switch.

<sup>2)</sup> 3 ... 98 % with programming device PPD05 (see page 133).

<sup>3)</sup> Within the compensated temperature range.

<sup>4)</sup> FKM sealings are only suitable for pressure ranges up to 0-16 bar.



# E.1

hex 24  
Performance  
adjustable at factory



hex 24

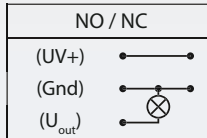

## 0500 / 0501

Electrical connectors and threads

**DIN EN 175301-803-A**

Pin	Assignment
1	U <sub>V+</sub>
2	Gnd
3	U <sub>out</sub>
PE	

IP65

x ~ 60 mm without socket device  
x ~ 77 mm with socket device

Connection code: 013

**M12 – DIN EN 61076-2-101 A**

Pin	Assignment
1	U <sub>V+</sub>
2	nc
3	Gnd
4	U <sub>out</sub>

IP67

x ~ 54 mm

Connection code: 002

**ISO 15170-A1-4.1**

Pin	Assignment
1	U <sub>V+</sub>
2	Gnd
3	U <sub>out</sub>
4	nc

IP67, IP6K9K

x ~ 56 mm

Connection code: 004

**AMP Superseal 1.5®**

Pin	Assignment
1	U <sub>out</sub>
2	Gnd
3	U <sub>V+</sub>

IP67

x ~ 61 mm

Connection code: 007

**Deutsch DT04-3P**

Pin	Assignment
A	U <sub>V+</sub>
B	Gnd
C	U <sub>out</sub>

IP67, IP6K9K

x ~ 61 mm

Connection code: 010

**Cable connection**

Pin	Assignment
red	U <sub>V+</sub>
white	U <sub>out</sub>
black	Gnd

IP67

x ~ 47 mm  
(+ 25 mm bend relief)  
Cable length ~ 2 m

Connection code: 011

Sealing ring

G 1/4 DIN  
EN ISO 1179-2  
(DIN 3852-11)  
form E

12

2

Thread code: 41

14

NPT 1/4

Thread code: 09



# 0500 / 0501

## Order matrix for electronic pressure switches

# E.1

hex 24  
Performance  
factory adjustable

	Type	Adjustment range	Pressure connection	Seal material	Electrical connection
Type	↓	↓	↓	↓	↓
Normally open (NO), PNP, set point - adjustment made by factory <sup>1)</sup>	0500				
Normally closed (NC), PNP, set point - adjustment made by factory <sup>1)</sup>	0501				

Max. overpressure <sup>2)</sup>	Burst pressure	Pressure range <sup>1)</sup>	
4 bar (58 psi)	8 bar (115 psi)	0 - 2 bar (approx. 29 psi)	200
10 bar (145 psi)	20 bar (290 psi)	0 - 4 bar (approx. 58 psi)	400
20 bar (290 psi)	35 bar (500 psi)	0 - 10 bar (approx. 145 psi)	101
40 bar (580 psi)	60 bar (870 psi)	0 - 16 bar (approx. 230 psi)	161
100 bar (1,450 psi)	140 bar (2,000 psi)	0 - 40 bar (approx. 580 psi)	401
150 bar (2,175 psi)	300 bar (4,350 psi)	0 - 100 bar (approx. 1,450 psi)	102
375 bar (5,439 psi)	500 bar (7,252 psi)	0 - 250 bar (approx. 3,626 psi)	252

Pressure connection ↓

1/4 BSPP – ISO 1179-2 (DIN 3852), form E, male thread	41
NPT 1/4	09

Seal material – Application areas ↓

NBR (BunaN)	Hydraulic/machine oil, heating oil, air, nitrogen, etc.	1
EPDM	Break fluid, ozone, acetylene, hydrogen, oxygen, etc.	2
FKM (Viton®) <sup>3)</sup>	Hydraulic fluids (HFA, HFB, HFD), petrol/gasoline, etc.	3
TPE	Mineral oil, HFC, HFD, water, water-salt solutions, methanol	7

Electrical connection ↓

DIN EN 175301-803-A (DIN 43650-A); socket device included	013
M 12x1 - DIN EN 61076-2-101-A	002
Bayonet ISO 15170-A1-4.1 (DIN 72585-A1-4.1)	004
AMP Superseal 1.5®	007
Deutsch DT04-3P	010
Cable connection (length of cable 6.5 ft / 2 m standard)	011

Order number:	05XX	XXX	XX	X	XXX
---------------	------	-----	----	---	-----

- 1) Please state switching point and hysteresis when ordering.
- 2) Static pressure, dynamic pressure 30 to 50% lower. Values refer to the hydraulic or pneumatic part of the electronic pressure switch.
- 3) FKM sealings are only suitable for pressure ranges up to 0-16 bar.



## E.2

hex 24

Performance

adjustable by user

# Electronic pressure switches, Performance series

hex 24, adjustable by user



- Very competitively priced electronic pressure switches
- High overpressure protection (up to 2 x)
- Small, compact electronic switches with ceramic sensor
- Easy adjustment of switching point from the outside using set screw
- Hysteresis adjustable within broad range (2 % – 98 %, set at factory)
- High level of adaptability to your requirements (custom solutions)
- Available as 'plasma cleaned for oxygen applications'<sup>1)</sup>

## Technical details

Type:	<b>0510 NO</b> <b>0511 NC</b>						
Transistor output	PNP output (High-Side N-channel)						
Supply voltage:	9.6 – 32 VDC with reverse voltage protection						
Output current:	0.5 A with ( $\leq 0.2$ A at $\geq 50$ °C) short-circuit and overvoltage protection						
Idle power consumption:	< 30 mA						
Standard pressure range $p_{nom}$ :	0 – 2 bar (29 psi)	0 – 4 bar (58 psi)	0 – 10 bar (145 psi)	0 – 16 bar (230 psi)	0 – 40 bar (580 psi)	0 – 100 bar (1,450 psi)	0 – 250 bar (3,625 psi)
Overpressure protection $p^{1)}$	4 bar (58 psi)	10 bar (145 psi)	20 bar (290 psi)	40 bar (580 psi)	100 bar (1,450 psi)	150 bar (2,175 psi)	375 bar (5,439 psi)
Burst pressure: <sup>1)</sup>	8 bar (115 psi)	20 bar (290 psi)	35 bar (500 psi)	60 bar (870 psi)	140 bar (2,000 psi)	300 bar (4,350 psi)	500 bar (7,251 psi)
Mechanical life expectancy:	5,000,000 pulsations at rise rates to 14.5 psi/ms (1 bar/ms) at $p_{nom}$						
Pressure rise:	14,503 psi (1,000 bar/s)						
Accuracy:	$\pm 0.5$ % of adjustment range $p_{nom}$ (full scale (FS)) at room temperature						
Switching point adjustment range:	3 ... 100 % of adjustment range $p_{nom}$ (FS), field adjustable						
Differential: <sup>2)</sup>	2 ... 98 % FS, programmable at factory (max. tolerance $\pm 1.0$ % of adjustment range $p_{nom}$ )						
Default-Hysteresis without order specification:	2 bar (29 psi)	4 bar (58 psi)	10 bar (145 psi)	16 bar (232 psi)	40 bar (580psi)	100 bar (1,450 psi)	250 bar (3,626 psi)
	0.1 bar	0.2 bar	0.5 bar	0.8 bar	2 bar	5 bar	10 bar
Resolution:	0.2% of adjustment range $p_{nom}$ (FS)						
Long term stability:	$\pm 0.1$ % of adjustment range $p_{nom}$ (FS) per year						
Repeatability: <sup>2)</sup>	$\pm 0.1$ % of adjustment range $p_{nom}$ (FS)						
Switching time:	< 4 ms						
Temperature error: <sup>2)</sup>	$\pm 0.04$ % of adjustment range $p_{nom}$ (FS) / °C						
Compensated temperature range:	+32 °F ... +158 °F (0 °C ... +70 °C), total error $\leq 2$ %						
Temperature range ambient:	-22 °F ... +212 °F (-30 °C ... +100 °C)						
Temperature range media:	with NBR (BunaN) seal: -22 °F ... +212 °F (-30 °C ... +100 °C)						
	with EPDM seal: -22 °F ... +257 °F (-30 °C ... +125 °C)						
	with FKM (Viton®) seal: -4 °F ... +257 °F (-20 °C ... +125 °C)						
	with TPE seal: -22 °F ... +230 °F (-30 °C ... +110 °C)						
Wetted parts material	Housing:	Stainless steel (AISI 303 /1.4305)					
	Measuring cell:	Ceramic					
	Seal material:	NBR (BunaN), EPDM, FKM <sup>3)</sup> (Viton®) or TPE					
Insulation resistance:	> 100 M $\Omega$ (500 VDC, $R_i > 42$ $\Omega$ )						
Vibration resistance:	20 g; at 4 ... 2000 Hz sine wave; DIN EN 60068-2-6						
Shock resistance:	500 m/s <sup>2</sup> ; 11 ms half sine wave; DIN EN 60068-2-27						
Protection class:	IP65: DIN EN 175301-803-A IP67: M12x1, AMP Superseal®, cable connector IP67 and IP6K9K: Bayonet ISO 15170-A1-4.1, Deutsch DT04-3P						
Electromagnetic compatibility:	EMC 2014/30/EU, EN 61000-6-2:2005, EN 61000-6-3:2007						
Cable output thread size:	For DIN EN 175301: PG9 (outside diameter of cable 6 to 9 mm)						
Weight:	approx. 2.82 oz / 80 g (DIN EN 175301 approx. 3.88 oz / 110 g)						

1) Static pressure, dynamic pressure 30 to 50 % lower. Values refer to the hydraulic or pneumatic part of the electronic pressure switch.

2) Within the compensated temperature range.

3) FKM sealings are only suitable for pressure ranges up to 0-16 bar.

# E.2

hex 24  
Performance  
adjustable by user



hex 24

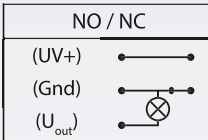

# 0510 / 0511

Electrical connectors and threads

**DIN EN 175301-803-A**

Pin	Assignment
1	U <sub>V+</sub>
2	Gnd
3	U <sub>out</sub>
PE	

IP65

x ~ 60 mm without socket device  
x ~ 77 mm with socket device

**Connection code: 013**

**M12-DINEN61076-2-101 A**

Pin	Assignment
1	U <sub>V+</sub>
2	nc
3	Gnd
4	U <sub>out</sub>

IP67

x ~ 54 mm

**Connection code: 002**

**ISO 15170-A1-4.1**

Pin	Assignment
1	U <sub>V+</sub>
2	Gnd
3	U <sub>out</sub>
4	nc

IP67, IP6K9K

x ~ 56 mm

**Connection code: 004**

**AMP Superseal 1.5®**

Pin	Assignment
1	U <sub>out</sub>
2	Gnd
3	U <sub>V+</sub>

IP67

x ~ 61 mm

**Connection code: 007**

**Deutsch DT04 - 3P**

Pin	Assignment
A	U <sub>V+</sub>
B	Gnd
C	U <sub>out</sub>

IP67, IP6K9K

x ~ 61 mm

**Connection code: 010**

**Thread code: 41**

**Thread code: 09**



# 0510 / 0511

## Order matrix for electronic pressure switches

## E.2

hex 24  
Performance  
field adjustable

	Type	Adjustment range	Pressure connection	Seal material	Electrical connection
--	------	------------------	---------------------	---------------	-----------------------

Type

Normally open (NO), PNP, set point -field adjustable <sup>1)</sup>	0510
Normally closed (NC), PNP, set point -field adjustable <sup>1)</sup>	0511

Max. overpressure <sup>2)</sup>	Burst pressure	Pressure range	
4 bar (58 psi)	8 bar (115 psi)	0 – 2 bar (approx. 29 psi)	200
10 bar (145 psi)	20 bar (290 psi)	0 – 4 bar (approx. 58 psi)	400
20 bar (290 psi)	35 bar (500 psi)	0 – 10 bar (approx. 145 psi)	101
40 bar (580 psi)	60 bar (870 psi)	0 – 16 bar (approx. 230 psi)	161
100 bar (1,450 psi)	140 bar (2,000 psi)	0 – 40 bar (approx. 580 psi)	401
150 bar (2,175 psi)	300 bar (4,350 psi)	0 – 100 bar (approx. 1,450 psi)	102
375 bar (5,439 psi)	500 bar (7,251 psi)	0 – 250 bar (approx. 3,625 psi)	252

Pressure connection

1/4 BSPP – ISO 1179-2 (DIN 3852), form E, male thread	41
NPT 1/4	09

Seal material – Application areas

NBR (BunaN)	Hydraulic/machine oil, air, nitrogen, etc.	1
EPDM	Break fluid, ozone, acetylene, hydrogen, oxygen, etc.	2
FKM (Viton®) <sup>3)</sup>	Hydraulic fluids (HFA, HFB, HFD), petrol/gasoline, etc.	3
TPE	Hydraulic / machine oil, air, nitrogen, water, acetylene, etc.	7

Electrical connection

DIN EN 175301-803-A (DIN 43650-A) coupler socket included in delivery	013
M 12x1 - DIN EN 61076-2-101-A	002
Bayonet ISO 15170-A1-4.1 (DIN 72585-A1-4.1)	004
AMP Superseal 1.5°	007
Deutsch DT04-3P	010

Order number:	051X	XXX	XX	X	XXX
---------------	------	-----	----	---	-----

- 1) Switching points and hysteresis can also be adjusted at factory.
- 2) Static pressure, dynamic pressure 30 to 50% lower. Values refer to the hydraulic or pneumatic part of the electronic pressure switch.
- 3) FKM sealings are only suitable for pressure ranges up to 0-16 bar.

## E.3

hex 27 / 30 A/F

adjustable by user

## Electronic pressure switches

hex 27 and 30 A/F, adjustable by user



- Ceramic sensor in thick film technology
- High overpressure protection to 500 bar
- Easy adjustment of switching point from the outside using set screw
- Hysteresis available within broad range (2 % – 95 %, set at factory)
- Very high switching currents (to 1.4 A)

## Technical details

Type:	0520 NO or NC		
Transistor output:	PNP output (High-Side N-channel)		
Supply voltage:	15 – 36 VDC		
Output current:	1.4 A transistor output (PNP, DC12) with short-circuit and overvoltage protection		
Idle power consumption:	< 15 mA		
Adjustment range $p_{nom}$ :	0 – 10 bar (145 psi)	0 – 100 bar (1,450 psi)	0 – 250 bar (3,625 psi)
Max. overpressure <sup>1)</sup> :	20 bar (290 psi)	150 bar (2,175 psi)	500 bar (7,250 psi)
Burst pressure <sup>1)</sup> :	25 bar (360 psi)	175 bar (2,540 psi)	600 bar (8,700 psi)
Mechanical life expectancy:	5,000,000 switching cycles in adjustment range at $p_{nom}$		
Pressure rise:	$\leq 14,500$ psi/s ( $\leq 1,000$ bar/s)		
Accuracy:	$\pm 0.5$ % of adjustment range $p_{nom}$ (full scale (FS)) at room temperature		
Switching point adjustment range:	2 ... 100 % of adjustment range $p_{nom}$ (FS), set from outside using set screw		
Differential:	2 ... 95 % FS, programmable at factory (max. tolerance $\pm 1.0$ % of adjustment range)		
Standard differential without order specification:	approx. 7.25 psi (0.5 bar)	approx. 72.5 psi (5 bar)	approx. 145 psi (10 bar)
Resolution:	0.15 % of adjustment range $p_{nom}$ (FS)		
Long term stability:	$\pm 0.1$ % of adjustment range $p_{nom}$ (FS) per year		
Repeatability <sup>2)</sup> :	$\pm 0.1$ % of adjustment range $p_{nom}$ (FS)		
Switching time:	< 4 ms		
Temperature error <sup>2)</sup> :	$\pm 0.04$ % of adjustment range $p_{nom}$ (FS) / °C		
Compensated temperature range:	+32 °F ... +158 °F (0 °C ... +70 °C), total error $\leq 2$ %		
Temperature range ambient:	-22 °F ... +176 °F (-30 °C ... +80 °C)		
Temperature range media:	with NBR (BunaN) seal: -22 °F ... +212 °F (-30 °C ... +100 °C)		
	with FKM (Viton®) seal: -4 °F ... +257 °F (-20 °C ... +125 °C)		
Wetted parts material	Housing:	zinc-plated steel	
	Measuring cell:	Ceramic	
	Seal material:	NBR (BunaN), EPDM or FKM (Viton®)	
Insulation resistance:	> 100 M.Ω (500 VDC, $R_i > 42$ ) Ω		
Vibration resistance:	10 g at 4 ... 2000 Hz sine wave; DIN EN 60068-2-6		
Shock resistance:	294 m/s <sup>2</sup> ; 11 ms half sine wave; DIN EN 60068-2-27		
Protection class:	IP65: (DIN EN 175301-803-A); IP67: (M12x1)		
Electromagnetic compatibility:	EMC 2014/30/EU, EN 61000-6-2:2005, EN 61000-6-3:2007		
Weight:	approx. 8.5 oz (240 g)		

<sup>1)</sup> Static pressure, dynamic pressure 30 to 50% lower. Value refers to the hydraulic or pneumatic part of the electronic pressure switch.

<sup>2)</sup> Within the compensated temperature range

# E.3

hex 27 / 30 A/F  
field adjustable



no / nc	
○ 1	(Uv+)
○ 2	(Gnd)
○ 3	(U <sub>out</sub> )

# 0520

Electrical connectors and threads

DIN EN 175301-803-A (DIN 43650-A)

Pin	Assignment
1	Uv+
2	Gnd
3	U <sub>out</sub>
PE	PE

IP65  
Cable output PG9  
(outside diameter of cable 6 to 9 mm)

Order number: 001

1/4 BSPP - female thread

Thread code: 14

M 12x1 - DIN EN 61076-2-101-A

Pin	Assignment
1	Uv+
2	nc
3	Gnd
4	U <sub>out</sub>

IP67

Order number: 002

Gasket

1/4 BSPP DIN EN ISO 1179-2 (DIN 3852-11) form E

Thread code: 41



# Menu-controlled electronic pressure switches

with display



- Menu-controlled, simple programming of switching functions
- 2 switching outputs and 1 analogue output
- Numerous programming functions, such as
  - switching time delay
  - zero point reset
  - peak value memory
  - switching point counter
- Current pressure value and switching states shown on 3-digit display
- Very high switching currents up to 1.4 A

# Menu-controlled electronic pressure switches

## Technical details

## E.4

### menu-controlled

0570 Electronic pressure switches		
Switching function:	NC/NO, programmable, 2 switching points, switching time delay, zero point reset, peak value memory (within adjustment range), switching point counter	
Settings:	Programmable using keypad on front	
Outputs:	2 transistor outputs (each 1.4 A DC12 / PNP) 1 analogue output (4 – 20 mA)	
Supply voltage $U_B$ :	12 - 30 VDC	
Switching status display:	2 LEDs (yellow)	
Pressure display:	Current pressure displayable in bar or PSI on 3-digit LED (red)	
Life expectancy:	5,000,000 switching cycles at rise rates to 1,000 bar/s at $p_{nom}$	
Pressure rise rate:	$\leq 14,500$ psi/s ( $\leq 1,000$ bar/s)	
Switching time:	$< 4$ ms	
Switching time delay:	Adjustable between 0 and 3.0 s	
Hysteresis:	1 – 99 % FS, programmable from keypad	
Accuracy:	$\pm 0.5$ % (FS at room temperature)	
Display accuracy:	$\pm 0.5$ % (FS at room temperature) $\pm 2$ digits	
Temperature drift:	$\pm 0.2$ % / 50 °F ( $\pm 0.2$ % / 10 °C)	
Temperature range:	NBR, FKM      -4 °F... +176 °F (-20 °C ... +80 °C)	
Compensated temperature range:	0 °C ... +70 °C (32 °F ... 158 °F), total error $\pm 2$ %	
Housing material:	die-casted zinc	
Wetted parts material	Housing:	anodised aluminium
	Measuring cell:	Ceramic
	Seal material:	NBR or FKM
Vibration resistance:	10 g at 5 ... 2000 Hz sine wave; DIN EN 60068-2-6	
Shock resistance:	294 m/s <sup>2</sup> ; 11 ms half sine wave; DIN EN 60068-2-27	
Protection class:	IP65	
Electromagnetic compatibility:	acc. to EN 50081-1, EN 50081-2, EN 50082-2	
Weight:	approx. 340 g	
Access PIN:	The switch can be protected with a pin between 1 and 999	

# E.4

menu-controlled

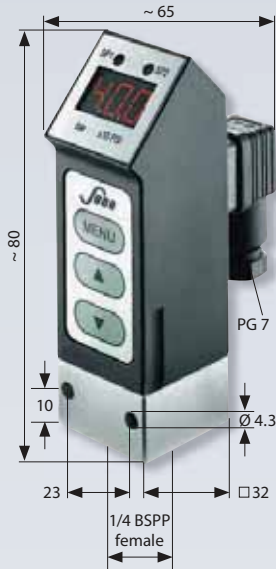

# 0570

Electronic pressure switches

- Anodised aluminium and die-casted zinc
- Ceramic measuring cell in thick-film technology
- Supply voltage 12 ... 30 VDC
- Overpressure protection to 290 / 2,175 / 7,200 psi (20 / 150 / 500 bar)<sup>1)</sup>
- Programmable using keypad on front
- Switching time delay (setting from 0 to 3 s)
- Peak value memory (within the measurement range)
- Pin protection possible to prevent misuse
- Socket device included

P <sub>max.</sub> in psi (bar)	Burst pressure in psi (bar)	Adjustment range in psi (bar)	Thread	Order number:
-----------------------------------	--------------------------------	----------------------------------	--------	---------------

### 0570 Electronic switches

290 psi <sup>1)</sup> (20 bar) <sup>1)</sup>	360 psi (25 bar)	0 – 145 psi (0 - 10 bar)	1/4 BSPP female	0570 – 467 14 – X – 001
2,175 psi <sup>1)</sup> (150 bar) <sup>1)</sup>	2,540 psi (175 bar)	0 – 1,450 psi (0 - 100 bar)		0570 – 468 14 – X – 001
7,250 psi <sup>1)</sup> (500 bar) <sup>1)</sup>	9,427 psi (650 bar)	0 – 5,800 psi (0 - 400 bar)		0570 – 469 14 – X – 001

### Seal material – Application areas

NBR (BunaN)	Hydraulic/machine oil, heating oil, air, nitrogen, etc.	1
FKM (Viton®)	Hydraulic fluids (HFA, HFB, HFD), petrol/gasoline, etc.	3



Order number:	0570 – 46X 14 – X – 001
---------------	-------------------------

### Wiring chart

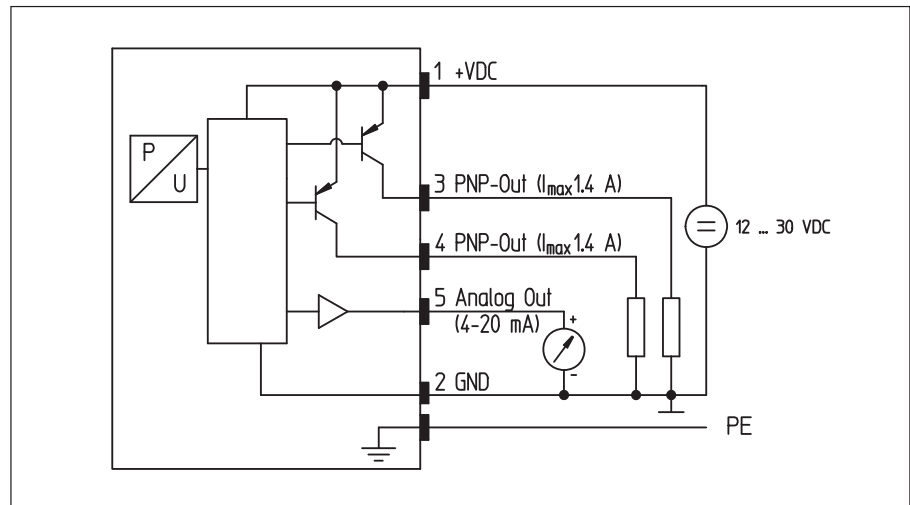

<sup>1)</sup> Static pressure, dynamic pressure 30 to 50% lower. Values refer to the hydraulic or pneumatic part of the electronic pressure switch.



E.5

hex 22

High Performance

1 switching output

# Electronic pressure switches, High-Performance series

hex 22 with one switching output



- Outstanding overpressure protection (up to 4 x)
- Ideal choice for mobile hydraulic applications
- Long service life even under high pressure change rates
- Wetted parts made of stainless steel and titanium ensuring excellent media compatibility
- All welded design, no elastomeric seal
- Silicon-on-sapphire technology (SoS) for highest reliability, accuracy and reliable process monitoring
- Very low temperature error and very good long-term stability
- Adjustment of switching point and hysteresis at factory

For versions with 2 switching outputs,  
please refer to chapter E.6, page 126

## Technical details

Silicon-on-Sapphire  
Sensor with One  
Switching Function

Type	0530 NO 0531 NC		0532 NO 0533 NC		
Number of transistor outputs:	1 PNP output (High Side N-channel MOSFET)		1 NPN output (Low Side N-channel MOSFET)		
Supply voltage:	9.6 – 32 VDC				
Idle power consumption:	< 15 mA				
Standard adjustment range p <sub>nom</sub>	0 – 10 bar (0 – 145 psi)	0 – 25 bar (0 – 360 psi)	0 – 100 bar (0 – 1,450 psi)	0 – 250 bar (0 – 3,625 psi)	0 – 600 bar (0 – 8,700 psi)
Overpressure protection p <sub>u</sub> <sup>1)</sup>	40 bar (580 psi)	100 bar (1,450 psi)	400 bar (5,800 psi)	1,000 bar (14,500 psi)	1,650 bar (29,930 psi)
Burst pressure <sup>1)</sup> :	80 bar (1,160 psi)	200 bar (2,900 psi)	800 bar (11,600 psi)	2,000 bar (29,000 psi)	2,000 bar (29,000 psi)
Mechanical life expectancy:	10,000,000 pulsations at rise rates to 72.5 psi/ms (5 bar/ms) at p <sub>nom</sub>				
Permitted pressure change rate:	≤ 72.5 psi/ms (≤ 5 bar / ms)				
Switching point adjustment range:	2 ... 100 % of the nominal pressure range (Full Scale, FS), programmable at factory				
Differential:	0.2 ... 99.8 % of the nominal pressure range (FS), programmable at factory (set to 5% of the switching point as standard)				
Accuracy:	±0.5 % of the nominal pressure range (FS) at room temperature, ±0.25 % BFSL				
Resolution:	0.1 % of the nominal pressure range (FS)				
Switching delay:	ON (0 ... 0.5 s) / OFF (0 ... 2 s) delay in increments of 1 ms, irrespective of switching point, programmable at factory (specify value when ordering, otherwise default value of 0 s is set)				
Output:	0.5 A transistor output with short-circuit and overvoltage protection				
Operating mode:	With differential or window mode, programmable at factory				
Long term stability:	±0.1 % FS p. a.				
Repeatability: <sup>2)</sup>	±0.1 % FS				
Temperature error: <sup>2)</sup>	±0.02 % / 1 K FS				
Compensated temperature range:	-4 °F ... +176°F (-20 °C ... +80°C)				
Temperature range media:	-40 °F ... +257°F (-40 °C ... +125°C)				
Temperature range ambient:	-40 °F ... +212°F (-40 °C ... +100°C)				
Wetted parts material:	Stainless steel AISI 303 (1.4305) and titanium				
Housing material:	Stainless steel AISI 303 (1.4305)				
Insulation resistance:	> 100 MΩ (500 VDC, Ri > 42 Ω)				
Switching time:	< 2 ms				
Vibration resistance:	20 g at 4 ... 2000 Hz sine wave; DIN EN 60068-2-6				
Shock resistance:	half sine wave 500 m/s <sup>2</sup> ; 11 ms; DIN EN 60068-2-27				
Protection class:	Refer to the electrical connections				
EMC:	EMC 2014/30/EU, EN 61000-6-2:2005, EN 61000-6-3:2007				
Protection against reverse polarity, short-circuit and over voltage surges:	built-in				
Weight:	approx. 2.8 oz / 80 g (DIN 175301 approx. 3.8 oz / 110 g, cable version approx. 4.8 oz / 135 g)				

1) Static pressure, dynamic value is 30 to 50 % lower. Values refer to the hydraulic/pneumatic part of the electronic pressure switch.

2) Within the compensated temperature range.

# E.5

hex 22

High Performance

1 switching output



hex 22

# 0530 / 0531 / 0532 / 0533

Electrical connectors and threads

### Connection diagrams

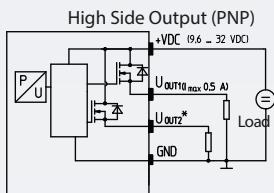

Pin assignment depending on electrical connections  
 \*U<sub>OUT2</sub> only for series 054x

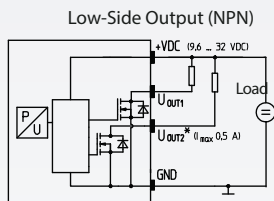

Pin assignment depending on electrical connections  
 \*U<sub>OUT2</sub> only for series 054x

Technical modifications and errors excepted.



**DIN EN 175301-803 - A**

Pin	Assignment
1	U <sub>V+</sub>
2	Gnd
3	U <sub>Out</sub>
PE	⏚

IP65  
 x ~ 60 / 76 mm\*  
 d ~ Ø 30 mm  
 Connection code: 013

**M12-DINEN 61076-2-101 A**

Pin	Assignment
1	U <sub>V+</sub>
2	nc
3	Gnd
4	U <sub>Out</sub>

IP67  
 x ~ 54 mm  
 d ~ Ø 22 mm  
 Connection code: 002

**ISO 15170 - A1 - 4.1**

Pin	Assignment
1	U <sub>V+</sub>
2	Gnd
3	U <sub>Out</sub>
4	nc

IP67, IP6K9K  
 x ~ 65 mm  
 d ~ Ø 27 mm  
 Connection code: 004

**AMP Superseal 1.5 °**

Pin	Assignment
1	U <sub>Out</sub>
2	Gnd
3	U <sub>V+</sub>

IP67  
 x ~ 73 mm  
 d ~ Ø 26 mm  
 Connection code: 007

\* x ~ 60 mm without socketdevice, x ~ 76 mm with socket device

**Deutsch DT04 - 4P**

Pin	Assignment
1	Gnd
2	U <sub>V+</sub>
3	nc
4	U <sub>Out</sub>

IP67, IP6K9K  
 x ~ 74 mm  
 d ~ Ø 23 mm  
 Connection code: 008

**Deutsch DT04 - 3P**

Pin	Assignment
A	U <sub>V+</sub>
B	Gnd
C	U <sub>Out</sub>

IP67, IP6K9K  
 x ~ 74 mm  
 d ~ Ø 23 mm  
 Connection code: 010

**Cable connection**

Pin	Assignment
red	U <sub>V+</sub>
white	U <sub>Out</sub>
black	Gnd

IP67  
 x ~ 44 mm  
 (+ 20 mm bend relief)  
 cable length ~ 2 m  
 d ~ Ø 22 mm  
 Connection code: 011

FKM-Sealing ring  
 1/4 BSPP  
 DIN EN ISO 1179-2  
 (DIN 3852-11), form E  
 Thread code: 41

1/4 BSPP  
 DIN 3852-A  
 Thread code: 03

NPT 1/8  
 Thread code: 04

NPT 1/4  
 Thread code: 09

M10x1  
 DIN 3852-A  
 Thread code: 30

7/16-20 UNF  
 Thread code: 20

9/16-18 UNF  
 Thread code: 21

FKM-Sealing ring  
 M14x1,5  
 DIN EN ISO 9974-2  
 (DIN 3852-11), form E  
 Thread code: 42

# 0530 / 0531 / 0532 / 0533

Order matrix for electronic pressure switches

## E.5

hex 22

Silicon-on-Sapphire  
Sensor with One  
Switching Function

	Type	Pressure range	Pressure connection	Pressure unit	Electrical connection
Type	↓	↓	↓	↓	↓
PNP output (High Side), NO	0530				
PNP output (High Side), NC	0531				
NPN output (Low Side), NO	0532				
NPN output (Low Side), NC	0533				

Max. overpressure <sup>2)</sup>	Burst pressure	Adjustment range <sup>1)</sup>	
40 bar (580 psi)	80 bar (1,160 psi)	0 – 10 bar (0 - 145 psi)	101
100 bar (1,450 psi)	200 bar (2,900 psi)	0 – 25 bar (0 - 362.5 psi)	251
400 bar (5,800 psi)	800 bar (11,600 psi)	0 – 100 bar (0 - 1,450 psi)	102
1,000 bar (14,500 psi)	2,000 bar (29,000 psi)	0 – 250 bar (0 - 3,625 psi)	252
1,650 bar (23,930 psi)	2,000 bar (29,000 psi)	0 – 600 bar (0 - 8,700 psi)	602

Pressure connection	
1/4 BSPP – DIN EN ISO 1179-2 (DIN 3852-11) form E	41
1/4 BSPP – DIN 3852-A	03
NPT 1/8	04
NPT 1/4	09
M 10x1 cyl. DIN 3852-A	30
7/16-20 UNF (max. 250 bar)	20
9/16-18 UNF	21
M 14x1.5 – DIN EN ISO 9974-2 (DIN 3852-11) form E	42

Pressure unit	
bar	B

Electrical connection	
DIN EN 175301-803-A (DIN 43650-A); socket device included	013
M 12 – DIN EN 61076-2-101 A	002
Bayonet ISO 15170-A1-4.1 (DIN 72585-A1-4.1)	004
AMP Superseal 1.5®	007
Deutsch DT04-4P	008
Deutsch DT04-3P	010
Cable connection (length of cable 6.5 ft / 2 m standard)	011

Order number:	05XX	XXX	XX	B	XXX
---------------	------	-----	----	---	-----

<sup>1)</sup> Please state switching point and hysteresis when ordering.

<sup>2)</sup> Static pressure, dynamic pressure 30 to 50% lower. Value refers to the hydraulic or pneumatic part of the electronic pressure switch.

## E.6

hex 22

High Performance

2 switching outputs

# Electronic pressure switches, High-Performance series

hex 22 with two switching outputs



- Outstanding overpressure protection (up to 4 x)
- Ideal choice for mobile hydraulic applications
- Long service life even under high pressure change rates
- Wetted parts made of stainless steel and titanium ensuring excellent media compatibility
- All welded design, no elastomeric seal
- Silicon-on-sapphire technology (SoS) for highest reliability, accuracy and reliable process monitoring
- Very low temperature error and very good long-term stability
- Adjustment of switching point and hysteresis at factory

For versions with 1 switching output,  
please refer to chapter E.5, page 122

## Technical details

Silicon-on-Sapphire  
Sensor with Two  
Switching Functions

Type	0540 NO / NO 0541 NC / NC 0542 NO / NC		0544 NO / NO 0545 NC / NC 0546 NO / NC		
Number of transistor outputs:	2 PNP outputs (High Side N-channel MOSFET)		2 NPN outputs (Low Side N-channel MOSFET)		
Supply voltage:	9.6 – 32 VDC				
Idle power consumption:	< 15 mA				
Standard-Adjustment range $p_{nom}$ :	0 – 10 bar (0 – 145psi)	0 – 25 bar (0 – 360psi)	0 – 100 bar (0 – 1,450psi)	0 – 250 bar (0 – 3,625psi)	0 – 600 bar (0 – 8,700psi)
Overpressure protection $p_u$ : <sup>1)</sup>	40 bar (580psi)	100 bar (1,450psi)	400 bar (5,800psi)	1,000 bar (14,500psi)	1,650 bar (23,930psi)
Burst pressure: <sup>1)</sup>	80 bar (1,160psi)	200 bar (2,900psi)	800 bar (11,600psi)	2,000 bar (29,000psi)	2,000 bar (29,000psi)
Mechanical life expectancy:	10,000,000 pulsations at rise rates to 72.5 psi/ms (5 bar/ms) at $p_{nom}$				
Permitted pressure change rate:	$\leq 72,518$ psi/s ( $\leq 5,000$ bar/s)				
Switching point adjustment range:	2 ... 100 % of the nominal pressure range (Full Scale, FS), programmable at factory				
Differential:	0.2 ... 99.8 % of the nominal pressure range (Full Scale, FS), programmable at factory (5 % of the switching point is set as standard)				
Accuracy:	$\pm 0.5$ % of the nominal pressure range (FS) at room temperature, $\pm 0.25$ % BFUL				
Resolution:	0.1 % of the nominal pressure range (FS)				
Switching delay:	ON (0 ... 0.5 s) / OFF (0 ... 2 s) delay in increments of 1 ms, irrespective of switching point, programmable at factory (specify value when Ordering, otherwise default value of 0 s is set)				
Output:	0.5 A transistor output with short-circuit and overvoltage protection				
Operating mode:	with hysteresis or window function (see page 101), programmable at factory				
Long term stability:	$\pm 0.1$ % FS p. a.				
Repeatability: <sup>2)</sup>	$\pm 0.1$ % FS				
Temperature error: <sup>2)</sup>	$\pm 0.02$ % / 1 K FS				
Compensated temperature range:	-4 °F ... +176°F		(-20 °C ... +80 °C)		
Temperature range media:	-40 °F ... +257°F		(-40 °C ... +125 °C)		
Temperature range ambient:	-40 °F ... +212°F		(-40 °C ... +100 °C)		
Wetted parts material:	Stainless steel AISI 303 (1.4305) and titanium				
Housing material:	Stainless steel AISI 303 (1.4305)				
Insulation resistance:	> 100 M $\Omega$ (500 VDC, $R_i > 42 \Omega$ )				
Switching time:	< 2 ms				
Vibration resistance:	20 g at 4 ... 2000 Hz sine wave; DIN EN 60068-2-6				
Shock resistance:	half sine wave 500 m/s <sup>2</sup> ; 11 ms; DIN EN 60068-2-27				
Protection class:	Refer to the electrical connections				
EMC:	EMC 2014/30/EU, EN 61000-6-2:2005, EN 61000-6-3:2007				
Short-circuit, overvoltage and reverse polarity protection	Built-in				
Weight:	approx. 2.8 oz / 80 g (DIN 175301 approx. 3.8 oz / 110 g, cable version approx. 4.7 oz / 135 g)				

<sup>1)</sup> Within the compensated temperature range.

<sup>2)</sup> Static pressure, dynamic value is 30 to 50 % lower. Values refer to the hydraulic/pneumatic part of the electronic pressure switch.

# E.6

hex 22  
High Performance  
2 switching outputs



hex 22

### Connection diagrams

High Side Output (PNP)

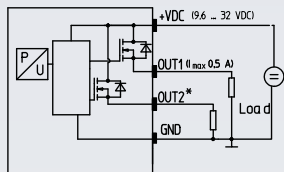

Pin assignment depending on electr. connection  
\*OUT2 only for 054x

Low Side Output (NPN)

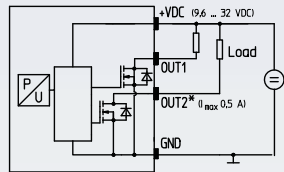

Pin assignment depending on electr. connection  
\*OUT2 only for 054x

Technical modifications and errors excepted.



# 0540 / 0541 / 0542 / 0544 / 0545 / 0546

Electrical connectors and threads

M 12 – DIN EN 61076-2-101 A

Pin	Assignment
1	Uv+
2	UOut 2
3	Gnd
4	UOut 1

IP67  
x ~ 54 mm  
d ~ Ø 22 mm  
Order number: 002

ISO 15170-A1-4.1

Pin	Assignment
1	Uv+
2	Gnd
3	UOut 1
4	UOut 2

IP67, IP6K9K  
x ~ 65 mm  
d ~ Ø 27 mm  
Order number: 004

DEUTSCH DT04-4P

Pin	Assignment
1	Gnd
2	Uv+
3	UOut 2
4	UOut 1

IP67, IP6K9K  
x ~ 74 mm  
d ~ Ø 23 mm  
Order number: 008

Cable connection

Pin	Assignment
red	Uv+
white	UOut 2
black	UOut 1
blue	Gnd

IP67  
x ~ 44 mm (+ 20 mm bend relief)  
Cable length ~ 6.5 ft (2 m)  
d ~ Ø 22 mm  
Order number: 011

Thread code: 41

Thread code: 03

Thread code: 04

Thread code: 09

Thread code: 30

Thread code: 20

Thread code: 21

Thread code: 42

# 0540 / 0541 / 0542 / 0544 / 0545 / 0546

Order matrix for electronic pressure switches

## E.6

hex 22

Silicon-on-Sapphire  
Sensor with Two  
Switching Functions

	Type	Pressure range	Pressure connection	Pressure unit	Electrical connection
--	------	----------------	---------------------	---------------	-----------------------

Type

PNP output (High Side), NO / NO (NO/NO)	0540
PNP output (High Side), NC / NC (NC/NC)	0541
PNP output (High Side), NO / NC (NO/NC)	0542
NPN output (Low Side), NO / NO (NO/NO)	0544
NPN output (Low Side), NC / NC (NC/NC)	0545
NPN output (Low Side), NO / NC (NO/NC)	0546

Max. overpressure <sup>2)</sup>	Burst pressure	Adjustment range <sup>1)</sup>	
40 bar (580 psi)	80 bar (1,160 psi)	0 – 10 bar (0 - 145 psi)	101
100 bar (1,450 psi)	200 bar (2,900 psi)	0 – 25 bar (0 - 362.5 psi)	251
400 bar (5,800 psi)	800 bar (11,600 psi)	0 – 100 bar (0 - 1,450 psi)	102
1,000 bar (14,500 psi)	2,000 bar (29,000 psi)	0 – 250 bar (0 - 3,625 psi)	252
1,650 bar (23,930 psi)	2,000 bar (29,000 psi)	0 – 600 bar (0 - 8,700 psi)	602

Pressure connection

1/4 BSPP – DIN EN ISO 1179-2 (DIN 3852-11) form E	41
1/4 BSPP – DIN 3852-A	03
NPT 1/8	04
NPT 1/4	09
M 10x1 cyl. DIN 3852-A	30
7/16-20 UNF	20
9/16-18 UNF	21
M 14x1,5 – DIN EN ISO 9974-2 (DIN 3852-11) form E	42

Pressure unit

bar	B
-----	---

Electrical connection

M 12 – DIN EN 61076-2-101 A	002
Bayonet ISO 15170-A1-4.1 (DIN 72585-A1-4.1)	004
Deutsch DT04-4P	008
Cable connection (length of cable 6.5 ft / 2 m standard)	011

Order number:	05XX	XXX	XX	B	XXX
---------------	------	-----	----	---	-----

<sup>1)</sup> Please state switching point and differential when ordering.

<sup>2)</sup> Static pressure, dynamic pressure 30 to 50% lower. Values refer to the hydraulic or pneumatic part of the electronic pressure switch.

# Accessories

Mating plugs, thread adapters and programming devices



- High-quality accessories
- Developed for our products
- Aligned to our products
- Direct from the manufacturer

# Mating plugs

For requirements at short notice and realising customized solutions

## E.7 Accessories

<p><b>Deutsch DT06-3S (for DT04-3P)</b> 3 x 0.5 mm<sup>2</sup> PUR cable (2 m), IP67</p>	<p>Suitable for connection code <b>010</b> <b>Deutsch DT04-3P</b></p>	<p>Article number: <b>1-1-36-653-160</b></p>
--	---	--



<p><b>TE AMP Superseal 1.5<sup>®</sup>, 3-pin</b> 3 x 0,5 mm<sup>2</sup> Radox Kabel (2 m), IP65</p>	<p>Suitable for connection code <b>007</b> <b>AMP Superseal 1.5<sup>®</sup></b></p>	<p>Article number: <b>1-1-32-653-158</b></p>
--	---	--



<p><b>M 12x1 DIN EN 61076-2-LF, 4-pin</b> 4 x 0,34 mm<sup>2</sup> PUR cable (2 m), IP65</p>	<p>Suitable for connection code <b>002</b> <b>M 12x1 DIN EN 61076-2-101 A</b></p>	<p>Article number: <b>1-1-00-653-162</b></p>
---	---	--



For the pin assignment of the wires please refer to chapter M.10 Accessories (page 91)

<p><b>Socket device M 12x1 DIN EN 61076-2-101 A straight, 4-pin</b></p> <p>Terminals for wire diameter 0.75 mm<sup>2</sup> (AWG 18)</p>	<p>Suitable for connection code <b>002</b> <b>M 12x1 DIN EN 61076-2-101-LF</b></p>	<p>Article number: <b>1-6-00-652-016</b></p>
---	--	--



<p><b>Socket device M 12x1 DIN EN 61076-2-101 A angled, 4-pin</b></p> <p>Terminals for wire diameter 0.75 mm<sup>2</sup> (AWG 18)</p>	<p>Suitable for connection code <b>002</b> <b>M 12x1 DIN EN 61076-2-101-LF</b></p>	<p>Article number: <b>1-6-00-652-017</b></p>
---	--	--



# E.7

## Accessories

# Thread adapters

For requirements at short notice and realising customized solutions

- The materials and shapes of thread adapters are aligned perfectly to our electronic pressure switches and transmitters
- Thread adapters are provided together with seals to ensure safe and easy installation of our electronic pressure switches and transmitters



### Stainless steel 1.4305 / AISI 303 thread adapters

#### G 1/4 DIN EN ISO 1179-1 (DIN 3852-E) female thread

			
<b>M10 x 1 form A</b> DIN 3852-1	<b>M14 x 1,5 form E</b> DIN 3852-E incl. sealing ring FKM	<b>NPT 1/4-18</b>	<b>9/16-18UNF</b> incl. O-ring FKM
hex 22 h = 30,5 mm	hex 22 h = 35 mm	hex 22 h = 35,5 mm	hex 22 h = 33 mm
Article number:	Article number:	Article number:	Article number:
<b>1-1-00-420-020</b>	<b>1-1-00-420-028</b>	<b>1-1-00-420-021</b>	<b>1-1-00-420-027</b>

# Programming device PPD05

for electronic pressure switches of the SUCO „Performance“ series

## 0500 / 0501

- simple connection to the PC / laptop via USB enables an easy and quick adjustment of technical parameters onsite
- individual programming of the switching points and the switch delay time (0 . . . 2 s); readout of max. pressure change rate as well as switching and overpressure cycles

## E.7

### Accessories

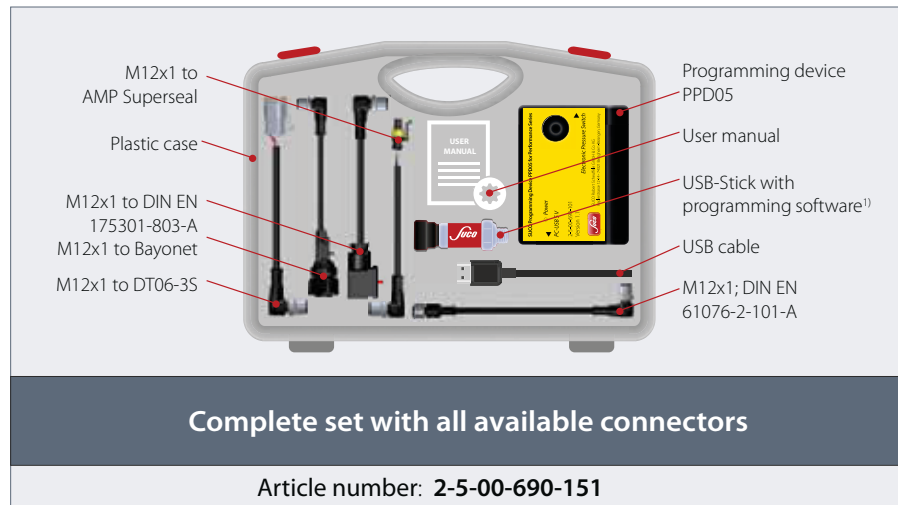
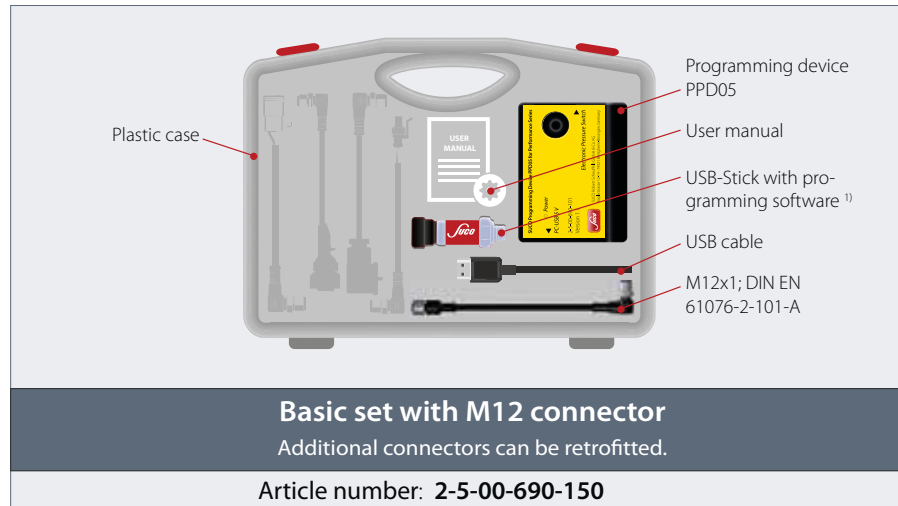

<sup>1)</sup> System requirements: min. Windows Vista OS.



<b>M12x1 – DT06-3S (für DT04-3P)</b> Adapter cable, 1 m	Article number: <b>1-0-00-653-214</b>
<b>M12x1 – DIN EN 175301-803-A</b> Adapter cable, 1 m	Article number: <b>1-0-00-653-210</b>
<b>M12x1 – Bajonett (DIN 72585)</b> Adapter cable, 1 m	Article number: <b>1-0-00-653-212</b>
<b>M12x1 – AMP Superseal 1.5®</b> Adapter cable, 1 m	Article number: <b>1-0-00-653-213</b>



For the pin assignment of the wires please refer to chapter M.10 Accessories (page 91)

# T. Pressure Transmitters



# T. Overview of pressure transmitters

Technical explanations  
for pressure transmitters

from page 138

Selection matrix  
A guide to choosing the correct pressure transmitter

from page 143

## Pressure Transmitters with ceramic measuring cell



T.1

T.1 Pressure transmitters, Performance series, hex 24 from page 144

Standard pressure ranges: 0 – 2 bar (0-14 psi), 0 – 4 bar (0-58 psi), 0 – 10 bar (0-145 psi), 0 – 16 bar (0-232 psi)  
0 – 40 bar (0-580 psi), 0 – 100 bar (0-1,540 psi), 0 – 250 bar (0-3,625 psi)

Overpressure protection: 2x

Output signal (alternative): 0 – 10 V or 4 – 20 mA

Housing materials: Stainless steel 1.4305 (AISI 303)

Sealing materials: NBR, EPDM, FKM, TPE

Threads: BSPP 1/4 E, NPT 1/4

Types: 0601, 0602



T.2

T.2 Robust pressure transmitter, hex 22, stainless steel „303“ from page 148

Standard pressure ranges: **-1 – 0 bar (vacuum), -1 – 1 bar (compound)**  
0 – 1 bar (0-14 psi), 0 – 4 bar (0-58 psi), 0 – 6 bar (0-87 psi), 0 – 10 bar (0-145 psi)  
0 – 16 bar (0-232 psi), 0 – 40 bar (0-580 psi), 0 – 100 bar (0-1,450 psi)

Overpressure protection: 2x

Output signal (alternative): 0.5 – 4.5 V ratiometric or 0 – 10 V or 4 – 20 mA

Housing materials: Stainless steel 1.4305 (AISI 303)

Sealing materials: NBR, EPDM, FKM

Thread: BSPP 1/4 E

Types: 0645, 0650, 0660



T.3

T.3 Robust pressure transmitter, hex 22, stainless steel „316L“ from page 152

Standard pressure ranges: **-1 – 0 bar (vacuum), -1 – 1 bar (compound)**  
0 – 1 bar (0-14 psi), 0 – 4 bar (0-58 psi), 0 – 6 bar (0-87 psi), 0 – 10 bar (0-145 psi)  
0 – 16 bar (0-232 psi), 0 – 40 bar (0-580 psi), 0 – 100 bar (0-1,450 psi)

Overpressure protection: 2x

Output signal (alternative): 0.5 – 4.5 V ratiometric or 0 – 10 V or 4 – 20 mA

Housing materials: Stainless steel 1.4404 (AISI 316L)

Sealing materials: NBR, EPDM, FKM

Thread: BSPP 1/4 E

Types: 0675, 0680, 0690

## Pressure Transmitters with SoS technology



T.4 Pressure transmitters, High-Performance series, hex 22 from page 156

Standard pressure ranges: 0 - 1 bar (0-14 psi), 0 - 2.5 bar (0-36 psi), 0 - 4 bar (0-58 psi), 0 - 6 bar (0-87 psi)  
 0 - 60 bar (0-870 psi), 0 - 100 bar (0-1,450 psi), 0 - 160 bar (0-2,320 psi)  
 0 - 250 bar (0-3,625 psi), 0 - 400 bar (0-5,800 psi), 0 - 600 bar (0-8,700 psi)

Overpressure protection: **Up to 4 x**  
 Output signal (alternative): 0.5 – 4.5 V ratiometric or  
 0 – 10 V or  
 4 – 20 mA

Housing materials: Stainless steel 1.4305 (AISI 303)  
 Sealing materials: **All welded, without elastomeric seal**  
 Thread: different male threads  
 Types: 0705, 0710, 0720



## Pressure Transmitters with CAN-Bus interface

CAN J1939

CANopen

T.5 Digital pressure transmitters, CANopen / J1939-Protocol, hex 22 from page 160

Standard pressure ranges: 0 - 1 bar (0-14 psi), 0 - 2.5 bar (0-36 psi), 0 - 4 bar (0-58 psi), 0 - 6 bar (0-87 psi)  
 0 - 10 bar (0-145 psi), 0 - 16 bar (0-232 psi), 0 - 25 bar (0-362 psi), 0 - 40 bar (0-580 psi)  
 0 - 60 bar (0-870 psi), 0 - 100 bar (0-1,450 psi), 0 - 160 bar (0-2,320 psi)  
 0 - 250 bar (0-3,625 psi), 0 - 400 bar (0-5,800 psi), 0 - 600 bar (0-8,700 psi)

Overpressure protection: Up to 2 x  
 Output protocol: **CANopen** DIN EN 50325-4  
**CAN J1939** SAE J1939

Housing materials: Stainless steel 1.4301 / AISI 304  
 Sealing materials: **All welded, without elastomeric seal**  
 Electrical connection: M12 DIN EN 61076-2-101 A,  
 CiA-DR303-1  
 Thread: BSPP 1/4 E, NPT 1/4  
 Types: 0630, 0631



T.6 Accessories from page 164

- Mating plugs
- Thread-Adapters
- Display



# Technical explanations for pressure transmitters

## What is a pressure transmitter?

A pressure transmitter (also called pressure transducer or pressure converter) is a component used to convert a pneumatic or hydraulic pressure to an electric (usually analogue and linear) output signal, such as a current or voltage.

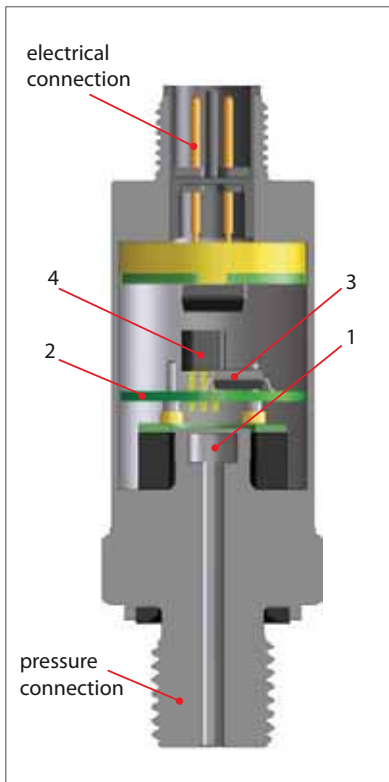

## How does a pressure transmitter work?

The pressure measuring cell fitted has a membrane (1) that is exposed to the pressure to be measured. Affixed on this membrane is a bridge circuit consisting of four ohmic resistors in the form of a Wheatstone bridge. The values of these resistors change proportionally to the pressure load present at the measuring cell or membrane. The bridge voltage of the measuring cell is amplified in the evaluation electronics (2) and processed digitally by a microcontroller (3).

The downstream output stage (4) converts this signal to the output signal required (such as 4 - 20 mA or 0 - 10 V).

## SoS technology

In the silicone-on-sapphire technology, the substrate of the thin film measuring cell is synthetic sapphire. This has excellent mechanical and temperature stable properties and prevents undesired parasitic effects, thereby having a positive effect on accuracy and stability. In conjunction with a titanium membrane, this results in virtually unique coaction between the temperature coefficients of sapphire and titanium.

This is because, unlike silicon and stainless steel, they are more closely matched and so only require a low level of compensation overhead. This also has a favourable effect on long-term stability.

## „Oil-filled“ stainless steel measuring cell

In this measuring cell technology, the piezoresistive measuring cell is packaged within a metallic housing filled with fluorine oil. This means the measuring cell is virtually free of external mechanical stress. Fluorine oil has excellent characteristics in regards to temperature and ageing behaviour, and is not flammable and so fits perfectly to oxygen applications. It is not recommended for food applications.

## Ceramic measuring cell / thick film technology

Ceramic thick film pressure measuring cells are made up of a sintered ceramic body. The ceramic body sleeve already has the key geometries for the subsequent pressure range. The membrane thickness required and thus, the pressure range required is established with grinding and lapping. The resistors are imprinted with thick film technology and interconnect to form a measuring bridge.

## Standard signals

Output signals 4 - 20 mA, 0 - 10 V and 0.5 - 4.5 V ratiometric in particular have established themselves in the industry. SUCO also offers transmitters with customer-specific output signals (such as 1 - 5 V).

Block diagram:

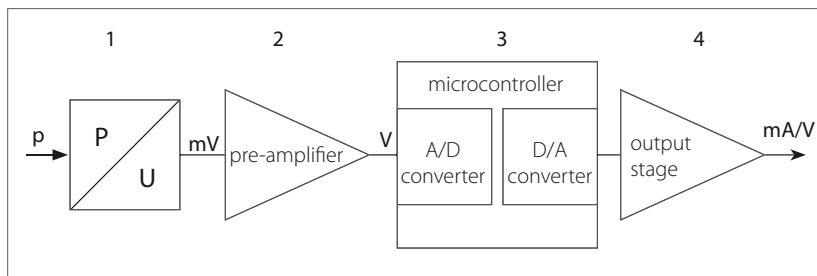

### Voltage output 0 - 10 V

Transmitters with an output signal of 0 to 10 V are a commonly used variant due to their simple initial operation and straight-forward scaling of the signal (0 V for 0 bar). The output load must be selected as highly resistive (with typical minimum value 4.7 kΩ). SUCO transmitters with voltage output have a 3-wire design.

The maximum connection length should not exceed 30 m to prevent significant voltage drops in the signal line.

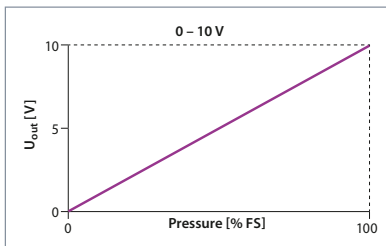

Conversion formula for pressure and voltage:

$$U_{\text{out}} = \frac{\text{pressure applied}}{\text{pressure range}} \times 10 \text{ V}$$

### Voltage output

#### 0.5 – 4.5 V ratiometric

SUCO transmitters with ratiometric output are operated with a 5 V supply voltage as 3-wire configuration. The output signal is directly proportional to / dependent on the supply voltage; this is known as a ratiometric dependency. 0.5 – 4.5 V is established as an output voltage because many A/D converters work with reference voltage  $U_{V+}$  of 5 V. The output voltage 0.5 V equals to 10% and 4.5 V corresponds to 90% of the supply voltage. The span is therefore 80% of the supply voltage.

This variant is used for example when a transmitter and a downstream A/D converter as an evaluation unit are to be powered with the same reference / operating voltage.

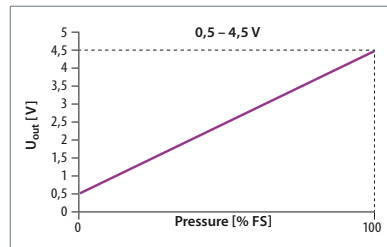

Conversion formula for pressure and voltage:

$$U_{\text{out}} = 0.1 \times U_{V+} + \frac{\text{pressure applied}}{\text{pressure range}} \times 0.8 \times U_{V+}$$

with  $U_{V+}$  = operating voltage

### Current output 4 – 20 mA

The most common analogue output signal of sensors is 4 – 20 mA current output (as 2-wire configuration). The advantage of a 4 – 20 mA output signal is the 4 mA offset which allows the monitoring of potential wire break and short-circuit (life zero signal).

The signal can also be transmitted over long distances with no loss in accuracy. This variant is also the least sensitive to EMC factors. 2-wire technology also means wiring overhead is reduced.

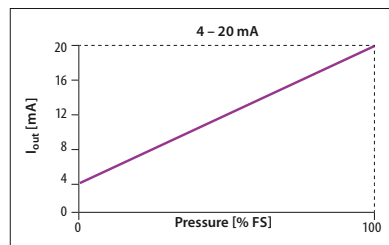

Conversion formula for pressure and voltage:

$$I_{\text{out}} = 4 \text{ mA} + \frac{\text{pressure applied}}{\text{pressure range}} \times 16 \text{ mA}$$

### Output for vacuum transmitters

As depicted in the sketch on the upper right, the output is at maximum signal at zero pressure. Therefore at maximum vacuum the output signal is at its minimum.

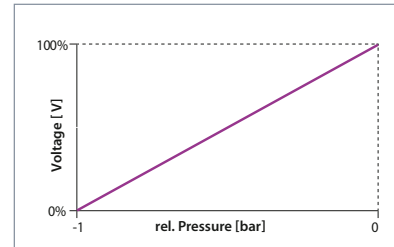

### Load / apparent ohmic resistance for pressure transmitters

An appropriate ohmic load must be connected to guarantee perfect functioning of a pressure transmitter.

For transmitters with a voltage output (V), the load should be at least 4.7 kΩ.

For transmitters with a current output (4 - 20 mA), the maximum load is calculated using the following formula:

$$R_L = \frac{U_{V+} - U_{V+(min)}}{20 \text{ mA}}$$

$U_{V+(min)}$  is the minimum supply voltage - to be taken from the data sheet.  $U_{V+(min)} = 10 \text{ V}$  gives the following operating range for example:

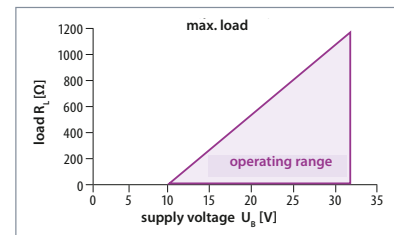

### Supply / operating voltage UB

All pressure transmitters work with DC voltage and have no galvanic isolation. Within the thresholds specified in the relevant data sheet, the supply voltage may change without influencing the output signal. (the ratiometric variant is an exception).

To guarantee the functionality of a transmitter, the minimum supply voltage may not fall below. The maximum operating voltage may not be exceeded to avoid damage on the electronics.

# Technical explanations for pressure transmitters

## Accuracy (to DIN EN 61298)

The (measuring) accuracy of pressure transmitters is specified by SUCO as  $\pm 0.5\%$  or  $\pm 1\%$  of the span (also called full scale). Accuracy includes zero point offset, non-linearity, hysteresis and non-repeatability, and is defined at room temperature and new state. This method defines the maximum deviation from the ideal line (in contrast to the BFSL method in which the average deviation is given). Other factors influencing the total accuracy, such as temperature and ageing, are specified separately.

## Non-linearity (to DIN EN 61298)

Non-linearity (also linearity) defines the deviation of the actual output curve from the theoretical ideal line. SUCO specifies the maximum error in relation to the overall span or full scale (FS) of the pressure range.

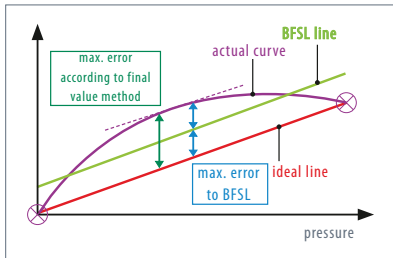

Non-linearity is also shown as BFSL (Best Fit Straight Line) as a reference value in the technical specifications. Non-linearity generally has the biggest influence on the overall error rate. Typically, non-linearity as per BFSL corresponds to half of non-linearity as per the full scale method ( $1\% \text{ FS} \sim 0.5\% \text{ BFSL}$ ).

## Hysteresis (to DIN EN 61298)

For a pressure transmitter, hysteresis specifies the difference of output signal between a rising and falling pressure, and is typically very low and negligible for SUCO pressure transmitters.

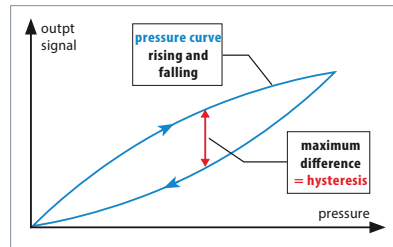

## Non-repeatability (to DIN EN 61298)

Non-repeatability defines reproducibility of the output signal. The pressure is attained three times for example - the maximum variance between these three values gives the non-repeatability.

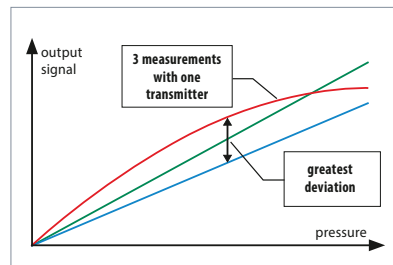

## Temperature errors and ranges

The temperature (both of the medium and ambience) generally has a significant influence on the accuracy of a pressure transmitter. Pressure transmitters are temperature compensated over a particular range corresponding to the typical application. This means that temperature errors within this temperature range are minimised by means of circuitry design and algorithms. The temperature error is added to the accuracy, and shown in the total error band of the pressure transmitter, also called butterfly graph. Outside the compensated temperature range, the maximum error is not defined, however the pressure transmitter still functions.

To prevent mechanical and electrical damage, pressure transmitters may not be deployed beyond the threshold temperature ranges specified in the data sheet.

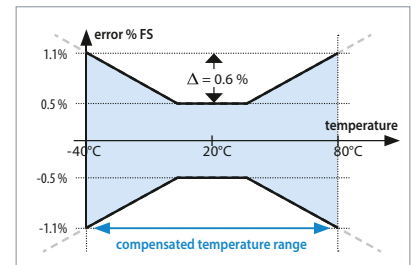

## Service life and long-term stability

Service life information pertains to nominal conditions specified in the data sheet, and can vary considerably when a product is operated mechanically or electrically outside the specifications. Service life essentially depends on the used measuring cell technology.

Ageing is accelerated (or slowed) due to different factors - such as temperature, temperature change and reduction of mechanical forces. The occurrence of ageing does effect the total accuracy.

SUCO specifies long-term stability in accordance with DIN 16086 in relation to one year. Typically the influence of aging on the accuracy reduces with increasing operating duration. The information in the data sheet corresponds to the worst case scenario.

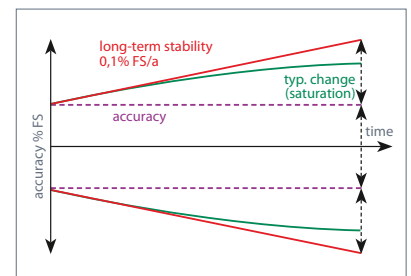

### Resolution

The A/D resolution (analogue - digital) of an pressure transmitter defines the smallest change of the analogue - digital - analogue conversion which takes place by the signal processing of an pressure transmitter.

If for example 13-bit resolution is used for an pressure transmitter with a 100 bar setting range, the smallest signal change is 8192 steps ( $2^{13}$ ). As state of the art a resolution of 12 bits and hence 4096 steps ( $2^{12}$ ) is typical. Therefore pressure changes of  $100 \text{ bar} / 4096 = 0.024 \text{ bar}$  can be recorded.

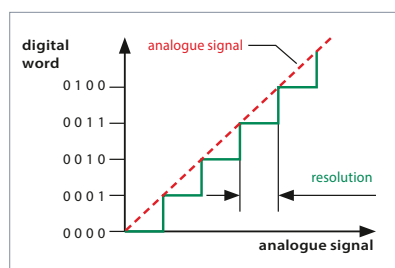

### Sampling rate

The sampling rate (or sampling frequency) defines the number of samples per time unit (typically in seconds or milliseconds) taken from an analogue signal and converted to a digital signal. The sampling rate is an indicator of how fast the output signal of a pressure transmitter responds to the pressure change at the input.

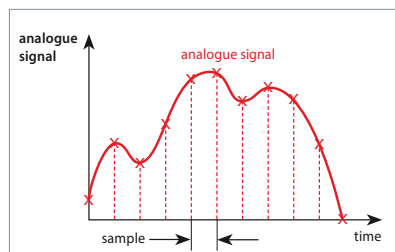

### Response time

The response or circuit time is shorter than 2 to 4 milliseconds (depending on model). The sum of A/D and D/A conversions, and the analogue and digital filters in the signal chain from the measuring bridge to the output, make up the response time. Filtering is used to suppress unwanted pressure peaks and electrical interference signals, and for good EMC characteristics.

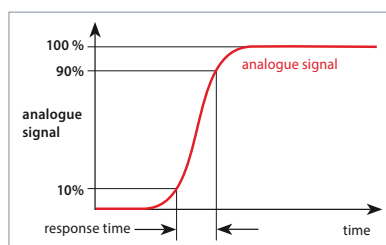

### CE mark

Pressure transmitters from SUCO fall under the 2014/30/EU EMC Directive.

EC declarations of conformity have been issued for the pressure transmitters are available on request or can be downloaded from our website. The relevant devices are denoted by a CE mark in our catalogue.

The Machinery Directive 2006/42 EC is not applicable, because our products are classed as components. Our products are designed for Group 2 fluids based upon good engineering practise in line with Pressure Equipment Directive 2014/68/EU, meaning neither a declaration of conformation may be issued nor a CE mark affixed.

### Electromagnetic compatibility (EMC)

Pressure transmitters from SUCO do comply to all important industrial EMC standards. The basis for the standards are the stricter thresholds for transient emissions in residential environments (EN 61000-6-3) and immunity for industrial environments (EN 61000-6-2).

Generic standard	Test standard	Parameter(s)
Radio disturbance and immunity	EN 55016-2-1 EN 55016-2-3	60 dBuV
Radiated, high-frequency electromagnetic field immunity test	EN 61000-4-3	10 V/m; 80-1000 MHz, 3 V/m; 1400-2000 MHz, 1 V/m; 2000-2700 MHz
Immunity to conducted disturbances, induced by radio-frequency fields	EN 61000-4-6	10 V; 0,15-80 MHz
Electrical fast transient / burst immunity test	EN 61000-4-4	±2 kV
Surge immunity test	EN 61000-4-5	±0,5 kV (common) ±0,5 kV (differential)
Electrostatic discharge (ESD) immunity test	EN 61000-4-2	air: 8 kV with contact: 4 kV

# Technical explanations for pressure transmitters

## Conversion chart for pressure units

Abbreviation for unit	Name of unit	Pa = N/m <sup>2</sup>	bar	Torr	lbf/in <sup>2</sup> , PSI
1 Pa = N/m <sup>2</sup>	Pascal	1	0.00001	0.0075	0.00014
1 bar	Bar	100 000	1	750.062	14.5
1 Torr = 1 mmHg	Millimeters of mercury	133.322	0.00133	1	0.01934
1 lbf/in <sup>2</sup> = 1 PSI	Pound-force per square inch	6894	0.06894	51.71	1

## Conversion chart for temperature units

	K	°C	F
K	1	K - 273.15	9/5 K - 459.67
°C	°C + 273.15	1	9/5 °C + 32
F	5/9 (F + 459.67)	5/9 (F - 32)	1

### Insulation strength

According to the latest specifications for immunity to surges and lightning protection, the following must be taken into account when testing insulation strength: With insulation test devices having an inner resistance exceeding 42 Ω, the insulation strength of pressure transmitters can be tested up to 500 VDC.

All contacts must be tested short-circuited against the housing. For a specific threshold value of test voltage, the protective circuit for surge protection is activated without any defects arising within the circuit. In the process, the current may rise to a point at which an insulation strength fault is indicated. The recommendation therefore is to conduct the insulation test of the pressure transmitter when it is removed, or independently of the overall system.

### Medium compatibility

The specifications on medium compatibility in this catalogue pertain to the specific seal and housing materials as well as the used measuring cell technology and so cannot be generalised.

### Stainless steel (1.4301 / AISI 304)

Stainless steel with broad level of media compatibility, such as water, steam, humidity and weak organic and inorganic acids

### Stainless steel (1.4305 / AISI 303)

Stainless steel with broad level of media compatibility. Also suitable for oxygen and hydrogen applications.

### Stainless steel (1.4404 / AISI 316L)

Stainless steel with broad level of media compatibility. Also suitable for chemical industry and sea water applications.

### Titanium

Its high levels of mechanical resistance and the wide media compatibility – in particular to corrosive media – do make titanium the ideal material for measuring cells and membranes. It is not recommended for oxygen or hydrogen applications.

### Oxygen and hydrogen

It is recommended to use an EPDM seal for the media oxygen / hydrogen to be monitored.

The EPDM seal of the „Performance“ series (pp. 144-147) was successfully tested at the BAM (Federal Institute for Materials Testing) up to 250 bar by means of an oxygen pressure shock test at 60 °C.

EPDM must not come into contact with oil, as this results in swelling and softening of the material and thus the failure of the transmitter.

Country-specific safety requirements and application guidelines must be observed if the medium to be monitored is oxygen or hydrogen, such as DGUV accident prevention regulations (DGUV 500, Section 2.32 and BGI 617).

**Please specify when ordering „for oxygen, oil and grease-free“ or order plasma cleaned and individually packaged transmitters (see also „Plasma cleaning for oxygen applications / LABS-free (PWIS-free)“ on page 9).**

### Pressure peak dampening

If required, our pressure transmitters can also be fitted with a pressure snubber (pressure peak orifice) to protect the measuring cell against transient pressure loads such as pressure peaks due to the switching of valves, cavitation effects, etc. which can shorten life expectancy.

For liquid media, the hole of a pressure snubber cannot be chosen to be any small size. At low temperatures the viscosity of the media will increase. In a case of dropping pressure the media might remain in the cavity behind the snubber which might affect the functionality of the pressure transmitter. Thus a bore diameter of 0.8 mm has been established.

### Product information

The technical information in this catalogue is based upon fundamental testing during product development, as well as upon empirical values. The information cannot be used for all application scenarios.

**Testing of the suitability of our products for a specific application (e.g. also the checking of material compatibilities) falls under the responsibility of the user. It may be the case that suitability can only be guaranteed with appropriate field testing.**

**Subject to technical changes.**

# Selection matrix for pressure transmitters

Type / series		0601	0602	0645	0650	0660	0675	0680	0690	0705	0710	0720	0630	0631
Page		147	147	151	151	151	155	155	155	159	159	159	163	163
Measuring cell technology	stainless steel, oilfilled, piezo-resistive			■	■	■	■	■	■					
	stainless steel, piezo-resistive												■	■
	ceramic / thick-film	■	■											
	SoS / titanim									■	■	■		
Function	overpressure	■	■	■	■	■	■	■	■	■	■	■	■	■
	vacuum			■	■	■	■	■	■					
Output	0.5 - 4.5 V ratiometric			■			■			■				
	0 - 10 V	■			■			■			■			
	4 - 20 mA		■			■			■			■		
	CAN												■	■
Operating voltage	5 VDC ± 10 %			■			■			■				
	(9,6 ... 12) - 32 VDC	■	■		■	■		■	■		■	■	■	■
Pressure range	-1 - 0 bar (-14 _ 0 psi)			■	■	■	■	■	■					
	-1 - 1 bar (-14 _ 14 psi) (compound)			■	■	■	■	■	■					
	0 - 1 bar (0 - 14 psi)			■	■	■	■	■	■				■	■
	0 - 2 bar (0-29 psi)	■	■											
	0 - 2.5 bar (0-36.26 psi)												■	■
	0 - 4 bar (0-58 psi)	■	■	■	■	■	■	■	■				■	■
	0 - 6 bar (0-87 psi)			■	■	■	■	■	■				■	■
	0 - 10 bar (0-145 psi)	■	■	■	■	■	■	■	■	■	■	■	■	■
	0 - 16 bar (0-232 psi)	■	■	■	■	■	■	■	■	■	■	■	■	■
	0 - 25 bar (0-362 psi)									■	■	■	■	■
	0 - 40 bar (0-580 psi)	■	■	■	■	■	■	■	■	■	■	■	■	■
	0 - 60 bar (0-870 psi)									■	■	■	■	■
	0 - 100 bar (0-1,450 psi)	■	■	■	■	■	■	■	■	■	■	■	■	■
	0 - 160 bar (0-2,320 psi)									■	■	■	■	■
	0 - 250 bar (0-3,626 psi)	■	■							■	■	■	■	■
	0 - 400 bar (0-5,800 psi)									■	■	■	■	■
	0 - 600 bar (0-8,702 psi)									■	■	■	■	■
Overpressure protection	up to 2x	■	■	■									■	■
	up tp 3x			■	■	■	■	■	■					
	up to 4x									■	■	■		
Compensated temperature range	0... +158 °F (0 ... +70 °C)	■	■											
	14... +158 °F (-10 ... +70 °C)			■	■	■	■	■	■					
	-4... +185 °F (-20 ... +85 °C)												■	■
	-40... +176 °F (-40 ... +80 °C)									■	■	■		
Size	hex 22			■	■	■	■	■	■	■	■	■	■	■
	hex 24	■	■											
Housing material	stainless steel 1.4201 / AISI 304												■	■
	stainless stell 1.4305 / AISI 303	■	■	■	■	■				■	■	■		
	stainless steel 1.4404 / AISI 316L						■	■	■					
Option	suitable for oxygen (on request)	■	■	■	■	■	■	■	■					



T.1

hex 24  
PerformancePressure transmitters,  
Performance series

hex 24



- Very attractively priced electronic pressure transmitters
- High overpressure protection (up to 2 x)
- Small, compact transmitters
- High level of adaptability to your requirements (custom solutions)
- Ceramic sensor in thick film technology
- Housing made of stainless steel (1.4305), others on request
- Available as 'plasma cleaned for oxygen applications'<sup>1)</sup>

<sup>1)</sup> For oxygen applications, the EPDM diaphragm can only be used up to 250 bar and a media temperature of max. +60°C.

# Pressure transmitters, Performance series

## Technical details

Type:	0601	0602
Output signal:	0 – 10 V (3-wire)	4 – 20 mA (2-wire)
Supply voltage $U_{V+}$ :	11 - 32 VDC with reverse voltage protection	9.6 - 32 VDC with reverse voltage protection
Permissible load apparent ohmic resistance:	$\geq 4.7 \text{ k}\Omega$	$\leq (U_{V+} - 10 \text{ V}) / 20 \text{ mA}$
Idle power consumption:	approx. 5 mA	< 4 mA

Type:	0601 / 0602						
Standard pressure ranges $p_{nom}$ :	0 - 2 bar (0 - 29 psi)	0 - 4 bar (0 - 58 psi)	0 - 10 bar (0 - 145 psi)	0 - 16 bar (0 - 230 psi)	0 - 40 bar (0 - 580 psi)	0 - 100 bar (0 - 1,450 psi)	0 - 250 bar (0 - 3,625 psi)
Overpressure protection $p_u^1$ :	4 bar (58 psi)	10 bar (145 psi)	20 bar (290 psi)	40 bar (580 psi)	100 bar (1,450 psi)	150 bar (2,175 psi)	375 bar (5,439 psi)
Burst pressure: <sup>1)</sup>	8 bar (115 psi)	20 bar (290 psi)	35 bar (500 psi)	60 bar (870 psi)	140 bar (2,000 psi)	300 bar (4,350 psi)	500 bar (7,250 psi)
Mechanical life expectancy:	5,000,000 pulsations at rise rates to 14,500 psi/s (1,000 bar/s) at $p_{nom}$						
Permitted pressure change rate:	$\leq 14,500 \text{ psi/s}$ ( $\leq 1,000 \text{ bar/s}$ )						
Accuracy:	$\leq \pm 1 \%$ full scale (FS) at room temperature, $\pm 0.5 \%$ BFSL						
Long term stability:	$\pm 0.3 \%$ of full scale (FS) per year						
Repeatability: <sup>2)</sup>	$\pm 0.1 \%$ FS						
Temperature error <sup>3)</sup> :	$\leq \pm 0.04 \%$ of full scale (FS) / °C						
Compensated temperature range:	32 °F ... +158 °F (0 °C ... +70 °C)						
Temperature range ambient:	-22 °F ... +212 °F (-30 °C ... +100 °C)						
Temperature range media:	with NBR (BunaN) seal: -22 °F ... +212 °F (-30 °C ... +100 °C)						
	with EPDM seal: -22 °F ... +257 °F (-30 °C ... +125 °C)						
	with FKM (Viton®) seal: -4 °F ... +257 °F (-20 °C ... +125 °C)						
	with TPE seal: -22 °F ... +230 °F (-30 °C ... +110 °C)						
Wetted parts material	Housing:	Stainless steel AISI 303 (1.4305)					
	Measuring cell:	Ceramic					
	Seal material:	NBR (BunaN), EPDM, FKM (Viton®) <sup>3)</sup> or TPE					
Insulation resistance:	> 100 M $\Omega$ (35 VDC)						
Response time 10 – 90 %:	$\leq 2 \text{ ms}$						
Vibration resistance:	20 g; at 4 ... 2000 Hz sine wave; DIN EN 60068-2-6						
Shock resistance:	half sine wave 500 m/s <sup>2</sup> ; 11 ms; DIN EN 60068-2-27						
Protection class	IP65: DIN EN 175301-803-A, IP67: M12x1, AMP Superseal 1.5°, cable connector IP67 and IP6K9K: Bayonet ISO 15170-A1-4.1, Deutsch DT04-3P						
Electromagnetic compatibility:	EMC 2014/30/EU, EN 61000-6-2:2005, EN 61000-6-3:2007						
Max. length of connection cable:	30 m						
Protection against reverse polarity, short-circuit and overvoltage:	Built-in						
Cable output thread size:	For DIN EN 175301: PG9 (outside diameter of cable 6 to 9 mm)						
Weight:	approx. 2.82 oz / 80 g (DIN EN 175301 approx. 3.88 oz / 110 g)						

<sup>1)</sup> Static pressure, dynamic pressure 30 to 50% lower. Values refer to the hydraulic or pneumatic part of the pressure transducer

<sup>2)</sup> Within the compensated temperature range

<sup>3)</sup> FKM sealings are only suitable for pressure ranges up to 0-16 bar.

# T.1

hex 24  
Performance



hex 24

# 0601 / 0602

Electrical connectors and threads

**DIN EN 17530-803-A**

Pin	0601	0602
1	$U_{V+}$	$U_{V+}$
2	Gnd	$I_{out}$
3	$U_{out}$	nc
PE		

IP65

x ~ 60 mm without socket device  
x ~ 77 mm with socket device

**Connection code: 013**

**M12-DINEN61076-2-101 A**

Pin	0601	0602
1	$U_{V+}$	$U_{V+}$
2	$U_{out}$	nc
3	Gnd	$I_{out}$
4	nc	nc

IP67

x ~ 54 mm

**Connection code: 002**

**ISO 15170 - A1 - 4.1**

Pin	0601	0602
1	$U_{V+}$	$U_{V+}$
2	Gnd	$I_{out}$
3	$U_{out}$	nc
4	nc	nc

IP67, IP6K9K

x ~ 56 mm

**Connection code: 015**

**AMP Superseal 1.5®**

Pin	0601	0602
1	$U_{out}$	nc
2	Gnd	$I_{out}$
3	$U_{V+}$	$U_{V+}$

IP67

x ~ 61 mm

**Connection code: 007**

**Deutsch DT04 - 3P**

Pin	0601	0602
A	$U_{V+}$	$U_{V+}$
B	Gnd	$I_{out}$
C	$U_{out}$	nc

IP67, IP6K9K

x ~ 61 mm

**Connection code: 014**

Sealing ring

G1/4 DIN  
EN ISO 1179-2  
(DIN 3852-11)  
form E

**Thread code: 41**

NPT 1/4

**Thread code: 09**



# 0601 / 0602

## Order matrix for pressure transducers

T.1

hex 24 Performance

	Type	Pressure range	Pressure connection	Seal material	Electrical connection
--	------	----------------	---------------------	---------------	-----------------------

0 – 10 V, 3-wire	0601
4 – 20 mA, 2-wire	0602

Max. overpressure <sup>1)</sup>	Burst pressure	Pressure range	
4 bar (58 psi)	8 bar (115 psi)	0 – 2 bar (approx. 29 psi)	200
10 bar (145 psi)	20 bar (290 psi)	0 – 4 bar (approx. 58 psi)	400
20 bar (290 psi)	35 bar (500 psi)	0 – 10 bar (approx. 145 psi)	101
40 bar (580 psi)	60 bar (870 psi)	0 – 16 bar (approx. 230 psi)	161
100 bar (1,450 psi)	140 bar (2,000 psi)	0 – 40 bar (approx. 580 psi)	401
150 bar (2,175 psi)	300 bar (4,350 psi)	0 – 100 bar (approx. 1,450 psi)	102
375 bar (5,439 psi)	500 bar (7,250 psi)	0 – 250 bar (approx. 3,625 psi)	252

### Pressure connection

1/4 BSPP – (DIN 3852), form E, male thread	41
NPT 1/4	09

### Seal material – Application areas

NBR (BunaN)	Hydraulic/machine oil, heating oil, air, nitrogen, water, etc	1
EPDM	Brake fluid, water, acetylene, hydrogen, oxygen etc.	2
FKM (Viton®) <sup>2)</sup>	Hydraulic fluids (HFA, HFB, HFD), petrol/gasoline, etc.	3
TPE	Hydraulic/machine oil, water, air, nitrogen, acetylene, etc.	7

### Electrical connection

DIN EN 175301-803-A (DIN 43650-A) ; socket device included	013
M 12x1 - DIN EN 61076-2-101-A	002
Bayonet ISO 15170-A1-4.1 (DIN 72585-A1-4.1)	015
AMP Superseal 1.5®	007
Deutsch DT04-3P	014

Order number:	06XX	XXX	XX	X	XXX
---------------	------	-----	----	---	-----

<sup>1)</sup> Static pressure, dynamic pressure 30 to 50% lower. Values refer to the hydraulic or pneumatic part of the pressure transducer.

<sup>2)</sup> FKM sealings are only suitable for pressure ranges up to 0-16 bar.

## T.2

hex 22

stainless steel

1.4305 / AISI 303

## Robust pressure transmitters

Stainless steel housing (1.4305 / AISI 303, hex 22)



- Pressure transmitters especially for low pressures, including vacuum applications
- High overpressure protection (up to 3 x)
- Long life time even under high pressure change rates
- Housing and wetted parts are made of stainless steel providing excellent media compatibility
- Suitable for hydrogen and oxygen applications<sup>1)</sup>
- The highly-sensitive piezo-resistive sensor in the measuring cell filled with oil guarantees high level of accuracy, repeatability and long-term stability
- The availability of different sealing materials enables deployment in a broad temperature range with a diverse array of media

<sup>1)</sup> For oxygen applications, the EPDM diaphragm can only be used up to 10 bar and a media temperature of max. +60°C.

## Technical details

Piezo-Resistive Sensor  
in Oil-Filled Housing  
Stainless Steel 303

Type:	0645	0650	0660
Output signal:	0.5 – 4.5 V ratiometric	0 – 10 V (3-wire)	4 – 20 mA (2-wire)
Supply voltage $U_B$ :	5 VDC $\pm 10\%$ max. 6.5 VDC	12 - 32 VDC	10 - 32 VDC
Permissible load apparent ohmic resistance:	$\geq 4,7\text{ k}\Omega$	$\geq 4,7\text{ k}\Omega$	$\leq (U - 10\text{ V}) / 20\text{ mA}$ v+
Idle power consumption:	approx. 5 mA		< 4 mA

Type:	0645 / 0650 / 0660								
Standard pressure ranges $p_{nom}$ :	-1 -0 bar (vacuum) (-14.5 - 0 psi)	-1-1 bar (compound)	0-1 bar (0 - 14 psi)	0 - 4 bar (0 - 58 psi)	0 - 6 bar (0 - 87 psi)	0 - 10 bar (0 - 145 psi)	0 - 16 bar (0 - 232 psi)	0 - 40 bar (0 - 580 psi)	0 - 100 bar (0 - 1,450 psi)
Overpressure protection $p_u^{1)}$ :	3 bar (43 psi)	3 bar (43 psi)	3 bar (43 psi)	8 bar (116 psi)	12 bar (174 psi)	20 bar (290 psi)	32 bar (464 psi)	80 bar (1,160 psi)	200 bar (2,900 psi)
Burst pressure $p_b^{1)}$ :	10 bar (145 psi)	10 bar (145 psi)	10 bar (145 psi)	20 bar (290 psi)	30 bar (435 psi)	35 bar (500 psi)	40 bar (580 psi)	100 bar (1,450 psi)	250 bar (3,625 psi)
Mechanical life expectancy:	10,000,000 pulsations at rise rates to 14,500 psi/s (1,000 bar/s) at $p_{nom}$								
Permitted pressure change rate:	$\leq 14,500\text{ psi/ms}$ ( $\leq 1,000\text{ bar/ms}$ )								
Accuracy:	$\pm 0.5\%$ full scale (FS) at room temperature, $\pm 0.25\%$ BFSL								
Long term stability:	$< \pm 0.2\%$ of full scale (FS) per year								
Repeatability $^{2)}$ :	$\pm 0.1\%$ FS								
Temperature error $^{2)}$ :	$\pm 0.02\%$ of full scale (FS) / °C; -1 ... 1 bar $\pm 0.03\%$ of full scale (FS) / °C								
Compensated temperature range:	-10°C ... +70°C (+14°F ... +158°F)								
Temperature range ambient:	-40°C ... +100°C (-40°F ... +212°F)								
Temperature range media:	with NBR (BunaN) seal: (-22°F ... +212°F) -30°C ... +100°C								
	with EPDM seal: (-22°F ... +257°F) -30°C ... +125°C								
	with FKM (Viton®) seal: (-4°F ... +257°F) -20°C ... +125°C								
Wetted parts material	Housing:	Stainless steel AISI 303 / 1.4305							
	Measuring cell:	Stainless steel AISI 316L / 1.4404							
	Seal material:	NBR (BunaN), EPDM or FKM (Viton®)							
Standard sensor oil:	Fluorine oil (not suitable for food applications)								
Insulation resistance:	$> 100\text{ M}\Omega$ (35 VDC)								
Response time 10 – 90%:	$< 2\text{ ms}$								
Vibration resistance:	20 g at 4 – 2000 Hz sine wave; DIN EN 60068-2-6								
Shock resistance:	half sine wave 500 m/s <sup>2</sup> 11ms; DIN EN 60068-2-27								
Protection class	Refer to the electrical connections								
Electromagnetic compatibility:	EMC 2014/30/EU, EN 61000-6-2:2005, EN 61000-6-3:2007								
Max. length of connection cable:	30 m								
Protection against reverse polarity, short-circuit and overvoltage:	Built-in								
Weight:	approx. 2.82 oz / 80 g (DIN EN 175301 approx. 3.88 oz / 110 g, cable output approx. 4.76 oz / 135 g)								

<sup>1)</sup> Static pressure. Dynamic value is 30 to 50% lower. Values refer to the hydraulic/pneumatic part of the pressure transducer.

<sup>2)</sup> Within the compensated temperature range.

# T.2

hex 22  
stainless steel  
1.4305 / AISI 303



# 0645 / 0650 / 0660

Electrical connectors and threads

**DIN EN 175301-803-A**

Pin	0645 / 0650	0660
1	$U_{V+}$	$U_{V+}$
2	Gnd	$I_{out}$
3	$U_{out}$	nc
PE		

IP65

$x \sim 60$  mm without socket device  
 $x \sim 76$  mm with socket device

$d \sim \varnothing 30$  mm

**Connection code: 013**

**M12 – DIN EN 61076-2-101 A**

Pin	0645 / 0650	0660
1	$U_{V+}$	$U_{V+}$
2	$U_{out}$	nc
3	Gnd	$I_{out}$
4	nc	nc

IP67

$x \sim 54$  mm

$d \sim \varnothing 22$  mm

**Connection code: 002**

**ISO 15170-A1-4.1**

Pin	0645 / 0650	0660
1	$U_{V+}$	$U_{V+}$
2	Gnd	nc
3	$U_{out}$	$I_{out}$
4	nc	nc

IP67

$x \sim 65$  mm

$d \sim \varnothing 27$  mm

**Connection code: 004**

**Cable connection**

1: red  
2: white  
3: black

Pin	0645 / 0650	0660
1	$U_{V+}$	$U_{V+}$
2	$U_{out}$	nc
3	Gnd	$I_{out}$

IP67

$x \sim 44$  mm (+ 20 mm bend relief)  
Cable length  $\sim 2$  m

$d \sim \varnothing 22$  mm

**Connection code: 011**

Sealing ring  
G1/4 DIN  
EN ISO 1179-2  
(DIN 3852-11)  
form E

**Thread code: 41**



# 0645 / 0650 / 0660

Article matrix for pressure transmitters

## T.2

hex 22

stainless steel

1.4305 / AISI 303

	Type	Pressure range	Pressure connection	Seal material	Electrical connection
--	------	----------------	---------------------	---------------	-----------------------

	↓	↓	↓	↓	↓
0.5 - 4.5 V ratiometric	0645				
0 - 10 V, 3-wire	0650				
4 - 20 mA, 2-wire	0660				

Pressure range	Max. Overpressure <sup>1)</sup>	
-1 - 0 bar (Vacuum, approx. -29.6 inHg)	3 bar (14.5 psi)	000
-1 - 1 bar (Compound pressure range)	3 bar (14.5 psi)	V01
0 - 1 bar (approx. 14.5 PSI)	3 bar (14.5 psi)	100
0 - 4 bar (approx. 58 PSI)	8 bar (116 psi)	400
0 - 6 bar (approx. 87 PSI)	12 bar (174 psi)	600
0 - 10 bar (approx. 145 PSI)	20 bar (290 psi)	101
0 - 16 bar (approx. 232 PSI)	32 bar (464 psi)	161
0 - 40 bar (approx. 580 PSI)	80 bar (1,160 psi)	401
0 - 100 bar (approx. 1,450 PSI)	200 bar (2,900 psi)	102

Pressure connection	
BSP 1/4 - DIN EN ISO 1179-2 (DIN 3852-11), form E	41

Seal material – Application areas

NBR	Hydraulic/machine oil, heating oil, air, nitrogen, water, etc.	-22 °F ... +212 °F (-30 °C ... +100 °C)	1
EPDM <sup>2)</sup>	Brake fluid, water, acetylene, hydrogen, etc.	-22 °F ... +257 °F (-30 °C ... +125 °C)	2
FKM	Hydraulic fluids (HFA, HFB, HFD), petrol/gasoline, etc.	-4 °F ... +257 °F (-20 °C ... +125 °C)	3

Electrical connection

DIN EN 175301-803-A (DIN 43650-A); socket device included	013
M12x1 - DIN EN 61076-2-101-A	002
Bayonet ISO 15170-A1-4.1 (DIN 72585-A1-4.1)	004
Cable connection (length of cable 2 m standard)	011

↓	↓	↓	↓	↓	
Article number:	06XX	XXX	41	X	XXX

<sup>1)</sup> Static pressure, dynamic pressure 30 to 50% lower. Values refer to the hydraulic or pneumatic part of the pressure transmitter.

<sup>2)</sup> For oxygen applications, the EPDM diaphragm can only be used up to 10 bar and a media temperature of max. +60°C.



## T.3

hex 22

stainless steel

1.4404 / AISI 316L

## Robust pressure transmitters

Stainless steel housing 1.4404 / AISI 316L, hex 22



- Pressure transmitters especially for low pressures, including vacuum applications
- Long life time even under high pressure change rates
- Housing and wetted parts are made of stainless steel 1.4404 providing excellent media compatibility when used in seawater, chemical and process technology applications
- The highly-sensitive piezo-resistive sensor in the measuring cell filled with oil guarantees high level of accuracy, repeatability and long-term stability
- The availability of different sealing materials enables deployment in a broad temperature range and with a diverse array of media

# Robust pressure transmitters

## Technical details

	0675	0680	0690
Output signal:	0.5 - 4.5 V ratiometric	0 - 10 V (3-wire)	4 - 20 mA (2-wire)
Supply voltage $U_{V+}$ :	5 VDC $\pm$ 10 % max. 6,5 VDC	12 - 32 VDC	10 - 32 VDC
Permissible load / apparent ohmic resistance:	$\geq$ 4.7 k $\Omega$	$\geq$ 4.7 k $\Omega$	$\leq (U_{V+} - 10 V) / 20 \text{ mA}$
Idle power consumption:	approx. 5 mA		< 4 mA

		0675 / 0680 / 0690								
Standard pressure ranges $p_{nom}$ :		-1 - 0 bar (vacuum) (-14.5-0 psi)	-1-1 bar (compound) (-14.5 to 14.5)	0 - 1 bar (0-14.5 psi)	0 - 4 bar (0-58 psi)	0 - 6 bar (0-87 psi)	0 - 10 bar (0-145 psi)	0 - 16 bar (0-232 psi)	0 - 40 bar (0-580 psi)	0 - 100 bar (0-1,450 psi)
Overpressure protection $p_v$ <sup>1)</sup> :		3 bar (43 psi)	3 bar (43 psi)	3 bar (43 psi)	8 bar (116 psi)	12 bar (174 psi)	20 bar (290 psi)	32 bar (464 psi)	80 bar (1,160 psi)	200 bar (2,900 psi)
Burst pressure <sup>1)</sup> :		10 bar (145 psi)	10 bar (145 psi)	10 bar (145 psi)	20 bar (290 psi)	30 bar (435 psi)	35 bar (500 psi)	40 bar (580 psi)	100 bar (1,450 psi)	250 bar (3,650 psi)
Mechanical life expectancy:	10,000,000 pulsations at rise rates to 14,500 psi/s (1,000 bar/s) at $p_{nom}$									
Permitted pressure change rate:	$\leq$ 14,500 psi/s ( $\leq$ 1,000 bar/s)									
Accuracy:	$\pm$ 0.5 % full scale (FS) at room temperature, $\pm$ 0.25 % BFSL									
Long term stability:	< $\pm$ 0.2 % of full scale (FS) per year									
Repeatability <sup>2)</sup> :	$\pm$ 0.1 % FS									
Temperature error <sup>2)</sup> :	$\pm$ 0.02 % of full scale (FS) / $^{\circ}\text{C}$ ; -1 ... 1 bar $\pm$ 0.03 % of full scale (FS) / $^{\circ}\text{C}$									
Compensated temperature range:	14 $^{\circ}\text{F}$ ... 158 $^{\circ}\text{F}$ (-10 $^{\circ}\text{C}$ ... +70 $^{\circ}\text{C}$ )									
Temperature range ambient:	-40 $^{\circ}\text{F}$ ... 212 $^{\circ}\text{F}$ (-40 $^{\circ}\text{C}$ ... +100 $^{\circ}\text{C}$ )									
Temperature range media:	with NBR seal: -22 $^{\circ}\text{F}$ ... +212 $^{\circ}\text{F}$ (-30 $^{\circ}\text{C}$ ... +100 $^{\circ}\text{C}$ )									
	with EPDM seal: -22 $^{\circ}\text{F}$ ... +257 $^{\circ}\text{F}$ (-30 $^{\circ}\text{C}$ ... +125 $^{\circ}\text{C}$ )									
	with FKM seal: -4 $^{\circ}\text{F}$ ... +257 $^{\circ}\text{F}$ (-20 $^{\circ}\text{C}$ ... +125 $^{\circ}\text{C}$ )									
Wetted parts material	Housing:	Stainless steel 1.4404 (AISI 316L)								
	Measuring cell:	Stainless steel 1.4404 (AISI 316L)								
	Seal material:	NBR, EPDM or FKM								
Standard sensor oil:	Fluorine oil <sup>3)</sup>									
Insulation resistance::	> 100 M $\Omega$ (35 VDC)									
Response time 10 - 90 %:	$\leq$ 2 ms									
Vibration resistance:	20 g at 4 - 2000 Hz sine wave; DIN EN 60068-2-6									
Shock resistance:	half sine wave 500 m/s <sup>2</sup> ; 11ms; DIN EN 60068-2-27									
Protection class	Refer to the electrical connections									
Electromagnetic compatibility:	EMC 2014/30/EU, EN 61000-6-2:2005, EN 61000-6-3:2007									
Max. length of connection cable:	30 m									
Protection against reverse polarity, short-circuit and overvoltage:	Built-in									
Weight:	approx. 80 g (DIN EN 175301 approx. 110 g, cable output approx. 135 g)									

<sup>1)</sup> Static pressure. Dynamic value is 30 to 50% lower. Values refer to the hydraulic/pneumatic part of the pressure transmitter.

<sup>2)</sup> Within the compensated temperature range.

<sup>3)</sup> not suitable for food applications

# T.3

hex 22  
stainless steel  
1.4404 / AISI 316L



# 0675 / 0680 / 0690

Electrical connectors and threads

**DIN EN 175301 - 803 - A**

Pin	0675 / 0680	0690
1	U <sub>V+</sub>	U <sub>V+</sub>
2	Gnd	I <sub>out</sub>
3	U <sub>out</sub>	nc
PE		

IP65

x ~ 60 mm without socket device  
x ~ 76 mm with socket device

d ~ Ø 30 mm

**Connection code: 013**

**M12 – DIN EN 61076 - 2 -101 A**

Pin	0675 / 0680	0690
1	U <sub>V+</sub>	U <sub>V+</sub>
2	U <sub>out</sub>	nc
3	Gnd	I <sub>out</sub>
4	nc	nc

IP67

x ~ 54 mm

d ~ Ø 22 mm

**Connection code: 002**

**ISO 15170-A1-4.1**

Pin	0675 / 0680	0690
1	U <sub>V+</sub>	U <sub>V+</sub>
2	Gnd	nc
3	U <sub>out</sub>	I <sub>out</sub>
4	nc	nc

IP67

x ~ 65 mm

d ~ Ø 27 mm

**Connection code: 004**

**Cable connection**

1: red  
2: white  
3: black

Pin	0675 / 0680	0690
1	U <sub>V+</sub>	U <sub>V+</sub>
2	U <sub>out</sub>	nc
3	Gnd	I <sub>out</sub>

IP67

x ~ 44 mm (+ 20 mm bend relief)  
Cable length ~ 2 m

d ~ Ø 22 mm

**Connection code: 011**

**Thread code: 41**

# 0675 / 0680 / 0690

Article matrix for pressure transmitters

## T.3

hex 22

stainless steel

1.4404 / AISI 316L

	Type	Pressure range	Pressure connection	Seal material	Electrical connection
--	------	----------------	---------------------	---------------	-----------------------



0.5 - 4.5 V ratiometric	0675
0 - 10 V, 3-wire	0680
4 - 20 mA, 2-wire	0690

Pressure range Max. Overpressure <sup>1)</sup>

-1 – 0 bar (Vacuum, approx. -29.6 inHg)	3 bar	000
-1 – 1 bar (Compound pressure range) <sup>2)</sup>	3 bar	V01
0 - 1 bar (approx. 14.5 PSI)	3 bar	100
0 - 4 bar (approx. 58 PSI)	8 bar	400
0 - 6 bar (approx. 87 PSI)	12 bar	600
0 - 10 bar (approx. 145 PSI)	20 bar	101
0 - 16 bar (approx. 232 PSI)	32 bar	161
0 - 40 bar (approx. 580 PSI)	80 bar	401
0 - 100 bar (approx. 1,450 PSI)	200 bar	102



Pressure connection

1/4 BSPP – DIN EN ISO 1179-2 (DIN 3852-11), form E	41
--	----



Seal material – Application areas

NBR	Hydraulic/machine oil, air, nitrogen, water, etc.	-22 °F ... +212 °F -30 °C ... +100 °C	1
EPDM <sup>3)</sup>	Brake fluid, water, acetylene, hydrogen, etc.	-22 °F ... +257 °F -30 °C ... +125 °C	2
FKM	Hydraulic fluids (HFA, HFB, HFD), petrol/gasoline, etc.	-4 °F ... +257 °F -20 °C ... +125 °C	3



Electrical connection

DIN EN 175301-803-A (DIN 43650-A); socket device included	013
M12x1 – DIN EN 61076-2-101 A	002
Bayonet ISO 15170-A1-4.1 (DIN 72585-A1-4.1)	004
Cable connection (length of cable 2 m standard)	011



Article number	06XX	XXX	41	X	XXX
----------------	------	-----	----	---	-----

<sup>1)</sup> Static pressure, dynamic pressure 30 to 50% lower. Values refer to the hydraulic or pneumatic part of the pressure transmitter.

<sup>2)</sup> Other compound pressure ranges on request.

<sup>3)</sup> For oxygen applications, the EPDM diaphragm can only be used up to 10 bar and a media temperature of max. +60°C.

T.4

hex 22  
High Performance

# Pressure transmitters High-Performance series

Silicon-on-sapphire sensor technology (SoS), hex 22



- Outstanding overpressure protection (up to 4 x)
- Ideal choice for mobile hydraulic applications
- Long service life even under high pressure change rates
- Wetted parts made of stainless steel and titanium ensuring excellent media compatibility
- All welded design, no elastomeric seal
- Silicon-on-sapphire technology (SoS) for highest reliability, accuracy and reliable process monitoring
- Very low temperature error and very good long-term stability
- Customer specific solutions available on request

# Pressure transmitters

## High-Performance series

### Technical details

	0705	0710	0720
Output signal:	0.5 - 4.5 V ratiometric	0 - 10 V (3-wire)	4 - 20 mA (2-wire)
Supply voltage $U_{V+}$ :	5 VDC $\pm$ 10 % max. 6.5 VDC	12 - 32 VDC	10 - 32 VDC
Permissible load / apparent ohmic resistance:	$\geq 4.7 \text{ k}\Omega$	$\geq 4,7 \text{ k}\Omega$	$\leq (U_{V+} - 10 \text{ V}) / 20 \text{ mA}$
Idle power consumption:	approx. 5 mA		< 4 mA

0705 / 0710 / 0720										
Pressure range in bar										
Standard pressure ranges $p_{\text{nom}}$ :	0 - 10	0 - 16	0 - 25	0 - 40	0 - 60	0 - 100	0 - 160	0 - 250	0 - 400	0 - 600
Overpressure protection $p_U$ : <sup>1)</sup>	40	64	100	160	240	400	640	1,000	1,600	1,650
Burst pressure <sup>3)</sup> :	80	128	200	320	480	800	1,280	2,000	2,000	2,000
Pressure range in PSI										
Standard pressure ranges $p_{\text{nom}}$ :	0 - 150	0 - 200	0 - 300	0 - 600	0 - 1,000	0 - 1,500	0 - 2,500	0 - 3,000	0 - 6,000	0 - 8,700
Overpressure protection $p_U$ : <sup>1)</sup>	300	580	580	1,450	2,900	2,900	5,800	5,800	10,870	12,180
Burst pressure <sup>3)</sup> :	450	870	870	2,175	4,350	4,350	8,700	8,700	14,500	15,230
Technical parameters										
Mechanical life expectancy:	10,000,000 pulsations at rise rates to 5,000 bar/s at $p_{\text{nom}}$									
Permitted pressure change rate:	$\leq 72,518 \text{ psi/s}$ ( $\leq 5,000 \text{ bar/s}$ )									
Accuracy:	$\pm 0.5 \%$ full scale (FS) at room temperature, $\pm 0.25 \%$ BFSL									
Long term stability:	$\pm 0.1 \%$ FS p. a.									
Repeatability : <sup>2)</sup>	$\pm 0.1 \%$ FS									
Temperature error : <sup>2)</sup>	$\pm 0.01 \%$ FS / °C									
Compensated temperature range:	-40 °F ... 176 °F (-40 °C ... +80 °C)									
Temperature range ambient:	-40 °F ... 212 °F (-40 °C ... +100 °C)									
Temperature range media:	-40 °F ... +257 °F (-40 °C ... +125 °C)									
Wetted parts material:	stainless steel 1.4305 / SAE Grade 303, titanium									
Insulation resistance:	> 100 M $\Omega$ (35 VDC)									
Response time 10 - 90 %:	$\leq 2 \text{ ms}$									
Vibration resistance:	20 g at 4 - 2000 Hz sine wave; DIN EN 60068-2-6									
Shock resistance:	half sine wave 500 m/s <sup>2</sup> ; 11 ms; DIN EN 60068-2-27									
Protection class:	IP67 for M12x1, DIN 72585 (bayonet) and cable connector IP65 for DIN EN 175301-803									
Electromagnetic compatibility:	EMC 2014/30/EU, EN 61000-6-2, EN 61000-6-3									
Max. length of connection cable:	30 m									
Protection against reverse polarity, short-circuit and overvoltage:	Built-in									
Weight:	approx. 80 g (DIN 175301 approx. 110 g, cable outlet approx. 135 g)									

<sup>1)</sup> Static value, dynamic value is 30 to 50% lower. Values refer to the hydraulic/pneumatic part of the pressure transmitter / transducer.  
<sup>2)</sup> Within the compensated temperature range.

# T.4

hex 22  
High Performance



# 0705 / 0710 / 0720

Electrical connectors and threads

**DIN EN 175301-803 - A**

Pin	0705 / 0710	0720
1	U <sub>out</sub>	nc
2	Gnd	I <sub>out</sub>
3	U <sub>V+</sub>	U <sub>V+</sub>
PE		

IP65  
x ~ 60 / 76 mm\*  
d ~ Ø 30 mm  
Connection code: 001

**M12 DIN EN 61076-2-101 A**

Pin	0705 / 0710	0720
1	U <sub>V+</sub>	U <sub>V+</sub>
2	U <sub>out</sub>	nc
3	Gnd	I <sub>out</sub>
4	nc	nc

IP67  
x ~ 54 mm  
d ~ Ø 22 mm  
Connection code: 002

**ISO 15170 - A1 - 4.1**

Pin	0705 / 0710	0720
1	U <sub>V+</sub>	U <sub>V+</sub>
2	Gnd	nc
3	U <sub>out</sub>	I <sub>out</sub>
4	nc	nc

IP67, IP6K9K  
x ~ 65 mm  
d ~ Ø 27 mm  
Connection code: 004

**AMP Superseal 1.5 °**

Pin	0705 / 0710	0720
1	U <sub>out</sub>	nc
2	Gnd	I <sub>out</sub>
3	U <sub>V+</sub>	U <sub>V+</sub>

IP67  
x ~ 73 mm  
d ~ Ø 26 mm  
Connection code: 007

\* x ~ 60 mm without coupler socket, x ~ 76 mm with coupler socket

**Deutsch DT04 - 4P**

Pin	0705 / 0710	0720
1	Gnd	I <sub>out</sub>
2	U <sub>V+</sub>	U <sub>V+</sub>
3	nc	nc
4	U <sub>out</sub>	nc

IP67, IP6K9K  
x ~ 74 mm  
d ~ Ø 23 mm  
Connection code: 008

**Deutsch DT04 - 3P**

Pin	0705 / 0710	0720
A	U <sub>V+</sub>	U <sub>V+</sub>
B	Gnd	nc
C	U <sub>out</sub>	I <sub>out</sub>

IP67, IP6K9K  
x ~ 74 mm  
d ~ Ø 23 mm  
Connection code: 010

**Cable connection**

Pin	0705 / 0710	0720
1	U <sub>V+</sub>	U <sub>V+</sub>
2	U <sub>out</sub>	nc
3	Gnd	I <sub>out</sub>

IP67  
x ~ 44 mm (+ 20 mm bend relief)  
Cable length ~ 2m  
d ~ Ø 22 mm  
Connection code: 011

Viton®-Sealing ring  
G1/4  
DIN EN ISO 1179-2 (DIN 3852-11) form E

**Thread code: 41**

G1/4  
DIN 3852-A

**Thread code: 03**

NPT 1/8

**Thread code: 04**

NPT 1/4

**Thread code: 09**

M10x1  
DIN 3852-A

**Thread code: 30**

7/16-20 UNF

**Thread code: 20**

9/16-18 UNF

**Thread code: 21**

FKM-Sealing ring  
M14x1.5  
DIN EN ISO 9974-2 (DIN 3852-11) form E

**Thread code: 42**



# 0705 / 0710 / 0720

Article matrix for pressure transmitters

## T.4

hex 22

High Performance

	Type	Pressure range bar / PSI	Pressure connection	Pressure unit	Electrical connection
0.5 - 4.5 V ratiometric	0705				
0 - 10 V, 3-wire	0710				
4 - 20 mA, 2-wire	0720				

Pressure range in bar <sup>1)</sup>

0 - 10 bar	101
0 - 16 bar	161
0 - 25 bar	251
0 - 40 bar	401
0 - 60 bar	601
0 - 100 bar	102
0 - 160 bar	162
0 - 250 bar	252
0 - 400 bar	402
0 - 600 bar	602

Pressure range in PSI <sup>1)</sup>

0 - 150 PSI	152
0 - 200 PSI	202
0 - 300 PSI	302
0 - 600 PSI	602
0 - 1,000 PSI	103
0 - 1,500 PSI	153
0 - 2,500 PSI	253
0 - 3,000 PSI	303
0 - 6,000 PSI	603
0 - 8,700 PSI	873

B  
P

Pressure connection

1/4 BSPP - DIN EN ISO 1179-2 (DIN 3852-11), form E	41
1/4 BSPP - DIN 3852-A	03
NPT 1/8 (max. to 250 bar)	04
NPT 1/4	09
M 10 x 1 cyl. DIN 3852-A (max. to 250 bar)	30
7/16 - 20 UNF (max. to 250 bar)	20
9/16 - 18 UNF	21
M 14 x 1,5 - DIN EN ISO 9974-2 (DIN 3852-11), form E	42

Pressure unit <sup>2)</sup>

bar	B
PSI	P

Electrical connection

DIN EN 175301-803-A (DIN 43 650-A) ; socket device included	001
M 12 - DIN EN 61076-2-101 A	002
Bayonet ISO 15170-A1-4.1 (DIN 72585-A1-4.1)	004
AMP Superseal 1.5°	007
Deutsch DT04-4P	008
Deutsch DT04-3P	010
Cable connection (length of cable 2 m standard)	011

Article number	07XX	XXX	/	XXX	XX	X	XXX
----------------	------	-----	---	-----	----	---	-----

<sup>1)</sup>The respective overpressure and burst pressure values of the individual pressure ranges (in bar and PSI) can be found in the „Technical data“ on page 157.

<sup>2)</sup>The pressure unit (bar or PSI) must correspond to the selected pressure range (in bar or PSI).

T.5

hex 22

stainless steel

CAN bus technology

# Digital Pressure Transmitter with CANopen / CAN J1939 Interface

Hex 22

**CAN J1939**

**CANopen**



- Type 0630: CANopen protocol according to CiA DS-301, Device profile according to CiA DS-404
- Type 0631: CAN J1939 protocol according to SAE J1939
- Robust stainless steel construction with high reliability, even in very rough environments
- Completely welded measuring cell made of stainless steel 1.4542 / AISI 630 ensures excellent media compatibility <sup>1)</sup>
- Measuring ranges from 0 - 1 bar to 0 - 600 bar

<sup>1)</sup> excludes pressure range from 0 - 1 bar consisting of completely welded oil-filled measuring cell made of stainless steel 1.4404 / AISI 316L.

# Digital Pressure Transmitter with CANopen / CAN J1939 Interface

## Technical details

	<b>0630</b>	<b>0631</b>
Output protocol:	CANopen DIN EN 50325-4 <sup>1) 2)</sup>	SAE J1939 <sup>1)</sup>
Supply voltage $U_B$ :	10 V - 32 VDC	10 V - 32 VDC
Idle power consumption:	< 30 mA	< 30 mA
CAN Interface:	acc. to DIN ISO 11898-2 CAN 2.0 A	acc. to DIN ISO 11898-2 CAN 2.0 B

<b>0630 / 0631</b>														
<b>Pressure ranges in bar</b>														
Standard pressure ranges $p_{nom}$ :	0 - 1	0 - 2.5	0 - 4	0 - 6	0 - 10	0 - 16	0 - 25	0 - 40	0 - 60	0 - 100	0 - 160	0 - 250	0 - 400	0 - 600
Overpressure protection $p_U$ <sup>3)</sup> :	2	6	10	20	20	40	100	100	200	200	400	750	750	840
Burst pressure <sup>3)</sup> :	5	9	15	30	30	60	150	150	300	300	600	1,000	1,000	1,050
<b>Pressure ranges in PSI</b>														
Standard pressure ranges $p_{nom}$ :	0 - 15	0 - 150	0 - 200	0 - 300	0 - 600	0 - 1,000	0 - 1,500	0 - 2,500	0 - 3,000	0 - 6,000	0 - 8,700			
Overpressure protection $p_U$ <sup>3)</sup> :	30	300	580	580	1,450	2,900	2,900	5,800	5,800	10,870	12,180			
Burst pressure <sup>3)</sup> :	75	450	870	870	2,175	4,350	4,350	8,700	8,700	14,500	15,230			
<b>Technical parameters</b>														
Mechanical life expectancy:	10,000,000 pulsations at rise rates to 1,000 bar/s at $p_{nom}$													
Permitted pressure change rate:	$\leq 1,000$ bar/s													
Accuracy:	$\pm 0.5$ % of full scale (FS) at room temperature <sup>4)</sup> , $\pm 0.25$ % BFSL													
Long-term stability:	$< \pm 0.1$ % of full scale (FS) per year													
Repeatability <sup>5)</sup> :	$\pm 0.1$ % of full scale (FS)													
Temperature error <sup>5)</sup> :	1.0 % of full scale (FS)													
Compensated temperature range:	-20 °C ... +85 °C													
Temperature range ambient:	-40 °C ... +105 °C													
Temperature range media:	-40 °C ... +125 °C													
Wetted parts material	Housing:	Stainless steel 1.4301 / AISI 304 (0 - 1 bar to 0 - 400 bar)   Stainless steel 1.4542 / AISI 630 (0 - 600 bar)												
	Measuring cell:	Stainless steel 1.4404 / AISI 316L (0 - 1 bar)   Stainless steel 1.4542 / AISI 630 (0 - 2.5 bar to 0 - 600 bar)												
Insulation resistance:	100 M $\Omega$ (50 VDC)													
Response time 10 - 90 %:	$< 1$ ms													
Vibration resistance:	20 g acc. to IEC 68-2-6 and IEC 68-2-36													
Shock resistance:	1000 g acc. to IEC 68-2-32													
Protection class:	IP67 (IP00 without mating plug)													
Electromagnetic compatibility:	EN 61326-2-3													
Weight	90 g													

<sup>1)</sup> Further information and the standard setting can be found in the Technical Documentation CANopen (1-6-30-628-058) and CAN J1939 (1-6-30-628-059) on our homepage at: <https://www.suco.de/en/downloads>.

<sup>2)</sup> The EDS (Electronic Data Sheet) of our CANopen device can be downloaded from our homepage at: <https://www.suco.de/en/downloads>.

<sup>3)</sup> Static pressure. Dynamic value is 30% to 50% lower. Values refer to the hydraulic/pneumatic part of the pressure transmitter.

<sup>4)</sup> Including non-linearity, hysteresis, repeatability, zero error and full scale (FS) according to IEC 61298-2.

<sup>5)</sup> Within the compensated temperature range. For pressure ranges  $< 3$  bar: 1.5 % of fullscale (FS)

# T.5

hex 22

stainless steel

CAN bus technology



# 0630 / 0631

Electrical connectors and threads

**M12 DIN EN 61076 - 2-101 A  
CiA-DR303-1**

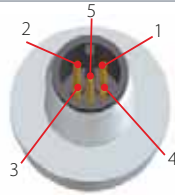

Pin	0630 / 0631
1	nc
2	U <sub>V+</sub>
3	Gnd
4	CAN-High
5	CAN-Low

IP67

x ~ 60 mm

d ~ Ø 22 mm

**Connection code: 032**

**G1/4 - DIN EN ISO 1179-2  
(DIN 3852-E)**

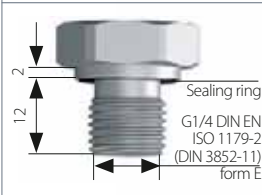

**Thread code: 41**

**NPT 1/4**

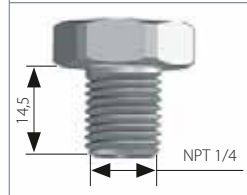

**Thread code: 09**

**CAN J1939**

**CANopen**



# 0630 / 0631

Article matrix for digital pressure transmitters

T.5

hex 22

stainless steel

CAN bus technology

	Type	bar	Pressure range / PSI	Pressure connection	Pressure unit	Electrical connection
--	------	-----	----------------------	---------------------	---------------	-----------------------

CANopen, CAN 2.0 A	<b>0630</b>
CAN J1939, CAN 2.0 B	<b>0631</b>

### Pressure range in bar <sup>1) 2)</sup>

0 - 1.0 bar	<b>100</b>
0 - 2.5 bar	<b>250</b>
0 - 4.0 bar	<b>400</b>
0 - 6.0 bar	<b>600</b>
0 - 10 bar	<b>101</b>
0 - 16 bar	<b>161</b>
0 - 25 bar	<b>251</b>
0 - 40 bar	<b>401</b>
0 - 60 bar	<b>601</b>
0 - 100 bar	<b>102</b>
0 - 160 bar	<b>162</b>
0 - 250 bar	<b>252</b>
0 - 400 bar	<b>402</b>
0 - 600 bar	<b>602</b>

### Pressure range in PSI <sup>1) 2)</sup>

0 - 15 PSI	<b>151</b>
0 - 150 PSI	<b>152</b>
0 - 200 PSI	<b>202</b>
0 - 300 PSI	<b>302</b>
0 - 600 PSI	<b>602</b>
0 - 1,000 PSI	<b>103</b>
0 - 1,500 PSI	<b>153</b>
0 - 2,500 PSI	<b>253</b>
0 - 3,000 PSI	<b>303</b>
0 - 6,000 PSI	<b>603</b>
0 - 8,700 PSI	<b>873</b>

### Pressure connection

G 1/4 - DIN 3852, form E, male thread	<b>41</b>
NPT 1/4	<b>09</b>

### Pressure unit

bar	<b>B</b>
PSI	<b>P</b>

### Electrical connection

M12x1 - DIN EN 61076-2-101 A, CiA-DR303-1	<b>032</b>
---	------------

Article no.	<b>063X</b>	<b>XXX</b>	/	<b>XXX</b>	<b>XX</b>	<b>X</b>	<b>032</b>
-------------	-------------	------------	---	------------	-----------	----------	------------

<sup>1)</sup> The proprietary PGN and SPN of the respective pressure range can be found in the Technical Documentation CAN J1939 (1-6-30-628-059) on our homepage at: <https://www.suco.de/en/downloads>.

<sup>2)</sup> The respective overpressure and burst pressure values of the individual pressure ranges (in bar and PSI) can be found in the „Technical data“ on page 161.

<sup>3)</sup> The pressure unit (bar or PSI) must correspond to the selected pressure range (in bar or PSI).



# T.6

Accessories

## Accessories

Mating plugs, thread adapters and transmitter display



- High-quality accessories
- Developed for our products
- Aligned to our products
- Direct from the manufacturer

# Mating plugs

For requirements at short notice and for realising custom solutions

T.6  
Accessories

<p><b>Deutsch DT06-3S (for DT04-3P)</b> 3 x 0,5 mm<sup>2</sup> PUR cable (2 m), IP67</p>	<p>Suitable for connection code <b>010</b> <b>Deutsch DT04-3P</b></p>	<p>Article number: <b>1-1-36-653-160</b></p>
--	---	--



<p><b>TE AMP Superseal 1.5®, 3-pin</b> 3 x 0,5 mm<sup>2</sup> Radox cable (2 m), IP65</p>	<p>Suitable for connection code <b>007</b> <b>AMP Superseal 1.5®</b></p>	<p>Article number: <b>1-1-32-653-158</b></p>
---	--	--

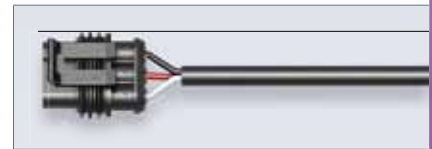

<p><b>M 12x1 DIN EN 61076-2-LF, 4-pin</b> 4 x 0,34 mm<sup>2</sup> PUR cable (2 m), IP65</p>	<p>Suitable for connection code <b>002</b> <b>M 12x1 DIN EN 61076-2-101 A</b></p>	<p>Article number: <b>1-1-00-653-162</b></p>
---	---	--



For the pin assignment of the wires please refer to chapter M.10 Accessories (page 91)

<p><b>Socket device</b> <b>M 12x1 DIN EN 61076-2-101 A straight, 4-pin</b>  Terminals for wire diameter 0.75 mm<sup>2</sup> (AWG 18)</p>	<p>Suitable for connection code <b>002</b>  <b>M 12x1</b> <b>DIN EN 61076-2-101-LF</b></p>	<p>Article number: <b>1-6-00-652-016</b></p>
--	--	--



<p><b>Socket device</b> <b>M 12x1 DIN EN 61076-2-101 A angled, 4-pin</b>  Terminals for wire diameter 0.75 mm<sup>2</sup> (AWG 18)</p>	<p>Suitable for connection code <b>002</b>  <b>M 12x1</b> <b>DIN EN 61076-2-101-LF</b></p>	<p>Article number: <b>1-6-00-652-017</b></p>
--	--	--



# T.6

Accessories

## Thread adapters

For requirements at short notice and for realising custom solutions

- The materials and shapes of thread adapters are aligned perfectly to our electronic pressure switches and transmitters
- Thread adapters are provided together with seals to ensure safe and easy installation of our electronic pressure switches and transmitters



**For G1/4 DIN EN ISO 1179-1 (DIN 3852-E)**  
SUCO thread code 41, transmitters and electronic pressure switches

### Stainless steel (1.4305 / AISI 303) thread adapters

G 1/4  
DIN EN ISO 1179-1 (DIN 3852-E)  
female thread

			
<b>M10 x 1 form A</b> DIN 3852-1	<b>M14 x 1.5 form E</b> DIN 3852-E incl. FKM sealing ring	<b>NPT 1/4-18</b>	<b>9/16-18UNF</b> incl. O-ring FKM
hex 22 h = 30,5 mm	hex 22 h = 35 mm	hex 22 h = 35,5 mm	hex 22 h = 33 mm
Article number:	Article number:	Article number:	Article number:
<b>1-1-00-420-020</b>	<b>1-1-00-420-028</b>	<b>1-1-00-420-021</b>	<b>1-1-00-420-027</b>

# SUCO Transmitter Display STD

- For pressure transmitters with 4 – 20 mA current output
- Suitable for pressure, temperature, level, force or flow indication
- Connection to DIN EN 175301-803-A (DIN 43650)
- Switching output option available (NO)

## Technical details

Display:	LED, red, 4-digits, rotatable (4x90°)
Display range:	-999 ... 9999
Input signal:	4 ... 20 mA, 2-wire
Standard display:	4.00 ... 20.00 (pre-set at factory)
Accuracy:	0.2 % FS ±1 digit
Supply voltage:	17 ... 32 VDC
Max. loop current:	60 mA
Sampling rate:	300 ms – 25.5 s (configurable with filter)
Switching output (for STD1 and STD3):	PNP transistor output 90 mA (P-MOSFET) Embedded overcurrent protection
Hysteresis (for STD1 and STD3):	constant value 3 digits of pre-setting (e. g.: switching point = 20.0 psi, hysteresis = 0.3 psi)
Programming:	2 programming buttons are located underneath the removable front panel
<b>Programming options:</b>	
Zero point setting:	-999 ... 9999
Range:	0 ... 9999
Decimal points:	3 positions or disable
Average filter:	0.3 ... 25.5 s
Overrun:	On / off
Switching point (for STD1 and STD3):	-999 ... 9999
Switch function (for STD1 and STD3):	NO
Save settings:	In EEPROM
Error messages:	If the overrun function is selected, „HI“ is shown on the display when 20 mA is exceeded. „LO“ is displayed when the current drops below 4 mA. When the overrun function is disabled, „ErC6“ is displayed as soon as the value is no longer in range -999 ... 9999.
Temperature range:	-10°C ... +60°C
Housing material:	ABS / acrylic (display window)
Protection class:	IP65 when fitted
Electrical connection:	DIN EN 175301-803-A (DIN 43650)
Attachment screw:	Included in the delivery

## Article number:

<b>1-6-20-656-007</b>	<b>STD0 Display (for 0720)</b>
<b>1-6-20-656-008</b>	<b>STD1 Display with switching output (for 0720)</b>
<b>1-6-20-656-013</b>	<b>STD2 Display (for 0602 / 0660 / 0690)</b>
<b>1-6-20-656-014</b>	<b>STD3 Display with switching output (for 0602 / 0660 / 0690)</b>

## T.6

### Accessories



#### Contact assignment:

PIN	Display (STD0)
1	nc
2	I <sub>out</sub>
3	U <sub>V+</sub>
PE	

PIN	Display with switching output (STD1):
1	PNP
2	I <sub>out</sub>
3	U <sub>V+</sub>
PE	

PIN	Display (STD2)
1	U <sub>V+</sub>
2	I <sub>out</sub>
3	nc
PE	

PIN	Display with switching output (STD3):
1	U <sub>V+</sub>
2	I <sub>out</sub>
3	PNP
PE	

S.

# ESI Sensor Technology

ESI Sensor Technology





# ESI Technology Ltd

The worldwide specialist for customised high precision electronic Pressure sensors



For decades, ESI Technology with headquarters in Wrexham (UK) has served its customers with consistent product development, special engineered solutions and outstanding technical service and sales support.

In 2009 ESI Technology Ltd was acquired by SUCO. Since then ESI stands for Electronics, Sensors and Instruments. By forming part of a bigger organisation, yet keeping its own independence, ESI has gained the strength to expand its sales efforts and services worldwide.

ESI Technology has become one of the leading suppliers for specialised Pressure sensors by offering bespoke solutions for specific applications.

With a dedicated manufacturing and engineering facility in Wrexham, ESI serves an extensive range of major industries such as Oil and Gas, Subsea, Aerospace, Process, Test and Calibration.

Being one of the key suppliers to these industries requires high performance not only of its products. From design and sourcing through to shipment and customer service, ESIs' Management System is approved to ISO 9001:2008.

ATEX, IECEx and DNV-GL approvals are also available for a wide range of products.

Throughout the product range, ESI uses a variety of state of the art sensor technologies to make each product a perfect fit to the desired application.

Though, the jewel of ESI's sensor technologies is Silicon-on-Sapphire which has redefined the performance capability of Pressure monitoring products.

Additional services, such as tailoring of the existing product range to suit application requirements, product conditioning such as ESS (Environmental Stress Screening) and product documentation packaging, make ESI the perfect partner for customers who need a bespoke service.

With a wide sales network, ESI Technology is able to deliver its' special services globally.

If you can't find the suitable solution on the following pages, please do not hesitate to contact the ESI Technology sales team or one of its partners which is worldwide at your site.

We are looking forward to supporting you!



# Pressure Sensors Overview

For full information, please ask for our brochure  
ESI - Electronic Pressure Sensors

## S.01 High-Pressure Transmitter

<b>Pressure Ranges:</b>	<b>0 – 600 bar; 0 – 1,000 bar; 0 – 1,500 bar; 0 – 2,000 bar; 0 – 3,000 bar; 0 – 4,000 bar; 0 – 5,000 bar (other ranges possible)</b>
Sensor Technology:	Silicon-on-Sapphire (SoS)
Accuracy:	≤ ±0.25 % FS typ. max., BFSL
Output Signal:	10 mV/V or 0 – 5 V or 0 – 10 V or 4 – 20 mA
Wetted Parts:	All titanium, machined from a single piece
Process Connection:	Autoclave F250-C female; M16 x 1.5 female
Option:	ATEX / IECEx (available only for 4 – 20mA), includes mining areas (Group I M1), DNV-GL certified option
Types:	HP1000; HP1001; HP1002; HP1003; HP1011; HP1012; HP1100; HP1101; HP1102; HP1103; HP1111; HP1112



## S.02 Low-Pressure Transmitter

<b>Pressure Ranges:</b>	<b>0 – 50 mbar; 0 – 100 mbar; 0 – 250 mbar; 0 – 500 mbar 0 – 1,000 mbar (other ranges possible)</b>
Sensor Technology:	Piezoresistive Silicon Sensor
Accuracy:	≤ ±0.5 % FS typ. max., BFSL
Output Signal:	10 mV/V (typ.) or 0 – 5 V or 0 – 10 V or 4 – 20 mA
Wetted Parts:	Stainless steel (SAE 316L) with O-ring
Process Connection:	¼" BSP (G ¼); ½" BSP; ¼" NPT; ½" NPT; (all male) (others on request)
Types:	LP1000; LP1001; LP1002; LP1003; LP1011; LP1012



## S.03 High-Precision Pressure Transducer

Pressure Ranges:	0 – 500 mbar to 0 – 1,500 bar
Sensor Technology:	Silicon-on-Sapphire (SoS)
<b>Accuracy:</b>	<b>≤ ±0.1 % FS typ. max., BFSL</b>
<b>Temperature Effects:</b>	<b>±1.0 % FS max. thermal error band over -20 °C ... +70 °C</b>
Output Signal:	10 mV/V (typ.) or 0 – 5 V or 0 – 10 V or
Wetted Parts:	All Titanium
Process Connection:	¼" BSP (G ¼); ¼" NPT; (all male)
Electrical Connection:	MIL-C-26482 6 pin Bayonet or 1 m PTFE cable
Option:	ATEX / IECEx (available only for mV output), includes mining areas (Group I M1)
Types:	HI2000; HI2001; HI2002; HI2010; HI2011; HI2012





# Pressure Sensors Overview



## 5.0 High-Temperature Pressure Transmitter

<b>Temperature Ranges:</b>	<b>Media temperature up to 250 °C</b>
Pressure Ranges:	0 – 1 bar up to 0 – 1,500 bar
Output Signal:	10 mV or 4 – 20 mA
Process Connection:	¼" BSP (G ¼); ¼" NPT; (all male) or ½" BSP flush diaphragm
Electrical Connection:	MIL-C-26482 6 pin Bayonet; 1 m PTFE cable; DIN EN 175301
Option:	ATEX / IECEx, includes mining areas (Group I M1)
Types:	HI2200; HI2210; HI2300; HI2310; HI6000; HI6001; HI6002; HI6003; HI6301; HI6302; HI6010; HI6011; HI6012; HI6013; HI6311; HI6312; PR3860; PR3861; PR3862

## 5.05 USB-Transducer

<b>Pressure Ranges:</b>	<b>-1 – 2.5 bar; 0 – 16 bar; 0 – 100 bar; 0 – 400 bar; 0 – 1,500 bar; 0 – 2,000 bar; 0 – 4,000 bar; 0 - 5,000 bar</b>
Sensor Technology:	Silicon-on-Sapphire (SoS)
Accuracy:	≤ ±0.15 % of span BFSL
Output Signal:	USB-Interface, power supply and data transfer via USB Mini B
Wetted Parts:	All titanium
Process Connection:	¼" BSP (G ¼); ¼" NPT; (all male) or Autoclave F-250-C female;
<b>Sample Rate:</b>	<b>up to 1,000 Hz</b>
Types:	GS4200-USB; GD4200-USB

## 5.06 Submersible Depth / Level Pressure Transmitter

<b>Pressure Ranges:</b>	<b>0 – 1 mWG up to 0 – 500 mWG (other Pressure ranges available)</b>
Accuracy:	≤ ±0.3 % of span BFSL
Output Signal:	4 – 20 mA (other options on request)
Electrical Connection:	Vented Cable
Option:	ATEX/IECEx, includes mining areas (Group I M1), DNV-GL certified option
Types:	PR3420; PR3441; PR3442

## 5.07 Flush Diaphragm Pressure Transmitter

<b>Pressure Ranges:</b>	<b>0 – 200 mbar up to 0 – 400 bar</b>
Sensor Technology:	Thick Film Ceramic Sensor
Accuracy:	≤ ±0.3 % of span BFSL
Output Signal:	4 – 20 mA (other options on request)
Wetted Parts:	Stainless steel 316
Process Connection:	½" BSP; Pipe-clamp; DIN 11851; (other options on request)
Option:	ATEX / IECEx, includes mining areas (Group I M1)
Types:	PR3800; PR3801; PR3802; PR3820; PR3821; PR3822; PR3850; PR3851; PR3852; PR3860; PR3861; PR3862

### S.08 Intrinsically Safe Pressure Transmitter

<b>Certification:</b>	<b>ATEX / IECEx approved for explosion protection for flammable gases (zone 0), dusts (zone 20) and mining areas (group I M1)</b>
Pressure Ranges:	0 – 100 mbar up to 0 – 1,500 bar
Output Signal:	4 – 20 mA
Process Connection:	¼" NPT (female standard) or ½" BSP male (G ½)
Options:	DNV-GL certified option
Types:	PR3900; PR3110EX



### S.09 Special and Customised Solutions

- Application Specific Design Solutions
- Customised Housing Design
- Choice of Output Signals and Pressure Ranges
- Specialised Process Connections
- Various Electrical Connectors
- Special Housing Materials



### S.10 Oil, Gas and Subsea Solutions

- Dual Redundancy (Pressure Sensors and Electronics)
- Hyperbaric Testing to 3,300 m Depth
- Environmental Stress Screening (ESS)
- Bespoke Process Connections
- Extended Service life
- Special Housing Materials
- Comprehensive Documentation Package and Certification



### S.11 Differential Pressure Transmitter

Pressure Ranges:	0 – 5 mbar up to 0 – 200 bar
Accuracy:	±0.3 % of span BFSL
Output Signal:	4 – 20 mA (other options on request)
<b>Wetted Parts:</b>	<b>Suitable for liquids or gases</b>
Option:	ATEX / ECEX, includes mining areas (Group I M1)
Types:	PR3200; PR3210; PR3220; PR3230; PR3240; PR3202; PR3203; PR3204



### S.12 Accessories

- Panel Meter
- High Temperature Pressure Adapter
- Adapters for Process Connectors





# Selection Matrix

■ ■ ■ Standard  
■ ■ ■ Optional

			Output signal	No. of wires	Silicon-on-Sapphire (SoS)	Bonded Foil Strain Gauge	Ceramic Thick Film	Isolated Piezoresistive	Piezoresistive Silicon
<b>Hispec</b> High Specification	<b>HI2000</b>	High-precision Pressure Transmitter (ATEX/IECEX option), cable outlet	10 mV/V	4	■				
	<b>HI2001</b>	High-precision Pressure Transmitter (0 - 1,500 bar), cable outlet	0-5 V	4	■				
	<b>HI2004</b>	High-precision Pressure Transmitter (0 - 1,500 bar), cable outlet	0-5 V	3	■				
	<b>HI2002</b>	High-precision Pressure Transmitter (0 - 1,500 bar), cable outlet	0-10 V	4	■				
	<b>HI2005</b>	High-precision Pressure Transmitter (0 - 1,500 bar), cable outlet	0-10 V	3	■				
	<b>HI2010</b>	High-precision Pressure Transmitter (ATEX/IECEX option), MIL-C-26482	10 mV/V	4	■				
	<b>HI2011</b>	High-precision Pressure Transmitter (0 - 1,500 bar), MIL-C-26482	0-5 V	4	■				
	<b>HI2014</b>	High-precision Pressure Transmitter (0 - 1,500 bar), MIL-C-26482	0-5 V	3	■				
	<b>HI2012</b>	High-precision Pressure Transmitter (0 - 1,500 bar), MIL-C-26482	0-10 V	4	■				
	<b>HI2015</b>	High-precision Pressure Transmitter (0 - 1,500 bar), MIL-C-26482	0-10 V	3	■				
<b>Hispec</b> High Temperature	<b>HI2200</b>	High temperature Pressure Transmitter up to 200 °C, cable outlet <sup>1)</sup>	10-20 mV/V	4	■				
	<b>HI2210</b>	High temperature Pressure Transmitter up to 200 °C, MIL-C-26482 <sup>1)</sup>	10-20 mV/V	4	■				
	<b>HI2300</b>	High temperature Pressure Transmitter up to 200 °C, cable outlet <sup>2)</sup>	10 mV/V	4	■				
	<b>HI2310</b>	High temperature Pressure Transmitter up to 200 °C, MIL-C-26482 <sup>2)</sup>	10 mV/V	4	■				
	<b>HI6000</b>	High temperature Pressure Transmitter up to 150 °C, cable outlet	0.5-4.5 V ratiometric	4	■				
	<b>HI6001</b>	High temperature Pressure Transmitter up to 150 °C, cable outlet	0-5 V	4	■				
	<b>HI6002</b>	High temperature Pressure Transmitter up to 150 °C, cable outlet	0-10 V	4	■				
	<b>HI6003</b>	High temperature Pressure Transmitter up to 150 °C, cable outlet	4-20 mA	2	■				
	<b>HI6301</b>	High temperature Pressure Transmitter up to 150 °C, cable outlet	0-5 V	3	■				
	<b>HI6302</b>	High temperature Pressure Transmitter up to 150 °C, cable outlet	0-10 V	3	■				
	<b>HI6010</b>	High temperature Pressure Transmitter up to 150 °C, D38999 (6-pin)	0.5-4.5 V ratiometric	4	■				
	<b>HI6011</b>	High temperature Pressure Transmitter up to 150 °C, D38999 (6-pin)	0-5 V	4	■				
	<b>HI6012</b>	High temperature Pressure Transmitter up to 150 °C, D38999 (6-pin)	0-10 V	4	■				
	<b>HI6013</b>	High temperature Pressure Transmitter up to 150 °C, D38999 (6-pin)	4-20 mA	2	■				
<b>GenSpec</b> General Purpose	<b>GS4200</b>	Multi-purpose Pressure Transmitter, socket device EN 175301-803-A	4-20 mA	2	■				
	<b>GS4201</b>	Multi-purpose Pressure Transmitter, socket device EN 175301-803-A	10 mV/V	4	■				
	<b>GS4202</b>	Multi-purpose Pressure Transmitter, socket device EN 175301-803-A	0-5 V	4	■				
	<b>GS4212</b>	Multi-purpose Pressure Transmitter, socket device EN 175301-803-A	0-5 V	3	■				
	<b>GS4203</b>	Multi-purpose Pressure Transmitter, socket device EN 175301-803-A	0-10 V	4	■				
	<b>GS4213</b>	Multi-purpose Pressure Transmitter, socket device EN 175301-803-A	0-10 V	3	■				
<b>GenSpec</b> USB	<b>GS4200-USB</b>	USB Pressure Transmitter GenSpec „Standard“ (5 Hz, 0 - 4,000 bar)	USB 2.0	n/a	■				
	<b>GD4200-USB</b>	USB Pressure Transmitter GenSpec „Dynamic“ (1,000 Hz, 0 - 5,000 bar)	USB 2.0	n/a	■				
<b>GenSpec</b> Standard Industrial	<b>GS4000</b>	Compact Pressure Transmitter, socket device EN 175301-803-C	2 mV/V	4		■			
	<b>GS4001</b>	Compact Pressure Transmitter, socket device EN 175301-803-C	0-5 V	4		■			
	<b>GS4011</b>	Compact Pressure Transmitter, socket device EN 175301-803-C	0-5 V	3		■			
	<b>GS4002</b>	Compact Pressure Transmitter, socket device EN 175301-803-C	0-10 V	4		■			
	<b>GS4012</b>	Compact Pressure Transmitter, socket device EN 175301-803-C	0-10 V	3		■			
	<b>GS4003</b>	Compact Pressure Transmitter, socket device EN 175301-803-C	4-20 mA	2		■			
	<b>GS4100</b>	Compact Pressure Transmitter, socket device EN 175301-803-C	2 mV/V	4			■		
	<b>GS4101</b>	Compact Pressure Transmitter, socket device EN 175301-803-C	0-5 V	4			■		
	<b>GS4111</b>	Compact Pressure Transmitter, socket device EN 175301-803-C	0-5 V	3			■		
	<b>GS4102</b>	Compact Pressure Transmitter, socket device EN 175301-803-C	0-10 V	4			■		
	<b>GS4112</b>	Compact Pressure Transmitter, socket device EN 175301-803-C	0-10 V	3			■		
	<b>GS4103</b>	Compact Pressure Transmitter, socket device EN 175301-803-C	4-20 mA	2			■		
	<b>Protran</b> Process	<b>PR3100</b>	Standard industrial Pressure Transmitter (0 - 1,000 bar)	4-20 mA	2		■	■	
<b>PR3101</b>		Standard industrial Pressure Transmitter (0 - 1,000 bar)	2 mV/V	4		■	■		
<b>PR3102</b>		Standard industrial Pressure Transmitter (0 - 1,000 bar)	0-5 V	4		■	■		
<b>PR3103</b>		Standard industrial Pressure Transmitter (0 - 1,000 bar)	0-10 V	4		■	■		
<b>PR3110EX</b>		ATEX/IECEX low Pressure Transmitter, socket device EN 175301-803-A	4-20 mA	2				■	

<sup>1)</sup> uncompensated and unrationalised output  
<sup>2)</sup> compensated and rationalised output





# Selection Matrix

<span style="color: red;">■</span> <span style="color: blue;">■</span> <span style="color: grey;">■</span>	Standard
<span style="border: 1px solid red;">□</span> <span style="border: 1px solid blue;">□</span> <span style="border: 1px solid grey;">□</span>	Optional

		Output signal	No. of wires	Silicon-on-Sapphire (SoS)	Bonded Foil Strain Gauge	Ceramic Thick Film	Isolated Piezoresistive	Piezoresistive Silicon
<b>Protran</b> Differential	<b>PR3200</b>	High Pressure Transmitter up to 200 bar for liquid media, DIN EN 175301-803-A	4-20 mA	2	■			
	<b>PR3210</b>	High Pressure Transmitter up to 200 bar for liquid media, DIN EN 175301-803-A	0-5 V	4	■			
	<b>PR3230</b>	High Pressure Transmitter up to 200 bar for liquid media, DIN EN 175301-803-A	0-5 V	3	■			
	<b>PR3220</b>	High Pressure Transmitter up to 200 bar for liquid media, DIN EN 175301-803-A	0-10 V	4	■			
	<b>PR3240</b>	High Pressure Transmitter up to 200 bar for liquid media, DIN EN 175301-803-A	0-10 V	3	■			
	<b>PR3202</b>	Low Pressure Transmitter for air/non-corrosive gas with screw terminals	4-20 mA	2				■
	<b>PR3203</b>	Low Pressure Transmitter for air/non-corrosive gas with screw terminals	0-5 V	3				■
	<b>PR3204</b>	Low Pressure Transmitter for air/non-corrosive gas with screw terminals	0-10 V	3				■
<b>Protran</b> Flush Diaphragm	<b>PR3800</b>	Flush diaphragm Pressure Transmitter (pipe clamp), DIN EN 175301-803-A	4-20 mA	2		■	■	
	<b>PR3801</b>	Flush diaphragm Pressure Transmitter (pipe clamp), DIN EN 175301-803-A	0-5 V	4		■	■	
	<b>PR3802</b>	Flush diaphragm Pressure Transmitter (pipe clamp), DIN EN 175301-803-A	0-10 V	4		■	■	
	<b>PR3820</b>	Flush diaphragm Pressure Transmitter (DIN11851 / SMS / RJT), DIN EN 175301-803-A	4-20 mA	2		■	■	
	<b>PR3821</b>	Flush diaphragm Pressure Transmitter (DIN11851 / SMS / RJT), DIN EN 175301-803-A	0-5 V	4		■	■	
	<b>PR3822</b>	Flush diaphragm Pressure Transmitter (DIN11851 / SMS / RJT), DIN EN 175301-803-A	0-10 V	4		■	■	
	<b>PR3850</b>	Flush diaphragm Pressure Transmitter (1/2" BSP), DIN EN 175301-803-A	4-20 mA	2		■		
	<b>PR3851</b>	Flush diaphragm Pressure Transmitter (1/2" BSP), DIN EN 175301-803-A	0-5 V	4		■		
	<b>PR3852</b>	Flush diaphragm Pressure Transmitter (1/2" BSP), DIN EN 175301-803-A	0-10 V	4		■		
	<b>PR3860</b>	Flush diaphragm Pressure Transmitter up to 250 °C, DIN EN 175301-803-A	4-20 mA	2		■		
	<b>PR3861</b>	Flush diaphragm Pressure Transmitter up to 250 °C, DIN EN 175301-803-A	0-5 V	4		■		
	<b>PR3862</b>	Flush diaphragm Pressure Transmitter up to 250 °C, DIN EN 175301-803-A	0-10 V	4		■		
<b>Protran</b> Submersible Depth / Level	<b>PR3420</b>	Submersible depth/level Pressure Transmitter, sludge platform, cable outlet	4-20 mA	2			■	
	<b>PR3441</b>	Submersible depth/level Pressure Transmitter, Ø 25 mm, cable outlet	4-20 mA	2			■	
	<b>PR3442</b>	Submersible depth/level Pressure Transmitter, Ø 16 mm, cable outlet	4-20 mA	2			■	
<b>Protran</b> Oil & Gas	<b>HI5000</b>	Downhole Pressure Transmitter up to 2,000 bar, NACE-certified	4-20 mA	2	■			
	<b>PR3900</b>	Hazardous area Pressure Transmitter, ATEX / IECEx, cable outlet	4-20 mA	2	■			
	<b>PR3913</b>	Control valve Pressure Transmitter down to 3,000 m depth, cable outlet	4-20 mA	2	■			
	<b>PR3914</b>	Subsea Pressure Transmitter down to 6,000 m depth, cable outlet	4-20 mA	2	■			
	<b>PR3915</b>	Dual redundant subsea Pressure Transmitter down to 3,000 m depth, cable outlet	4-20 mA	2	■			
	<b>PR3920</b>	DP control valve subsea Pressure Transmitter down to 3,000 m depth, cable outlet	4-20 mA	2	■			
<b>Protran</b> Heavy Duty	<b>PR9000</b>	Process Pressure Transmitter up to 1,500 bar, screw terminal / P68 cable gland	4-20 mA	2	■		■	
	<b>PR9500</b>	Wireless Pressure Transmitter up to 1,500 bar, screw terminal / P68 cable gland	4-20 mA	2	■		■	
<b>Hipres</b> High Pressure	<b>HP1000</b>	High Pressure Transmitter up to 2,000 bar, DIN EN 175301-803-A	10 mV/V	4	■			
	<b>HP1001</b>	High Pressure Transmitter up to 2,000 bar, DIN EN 175301-803-A	0-5 V	4	■			
	<b>HP1011</b>	High Pressure Transmitter up to 2,000 bar, DIN EN 175301-803-A	0-5 V	3	■			
	<b>HP1002</b>	High Pressure Transmitter up to 2,000 bar, DIN EN 175301-803-A	0-10 V	4	■			
	<b>HP1012</b>	High Pressure Transmitter up to 2,000 bar, DIN EN 175301-803-A	0-10 V	3	■			
	<b>HP1003</b>	High Pressure Transmitter up to 2,000 bar, DIN EN 175301-803-A	4-20 mA	2	■			
	<b>HP1100</b>	High Pressure Transmitter from 2,500 to 5,000 bar, DIN EN 175301-803-A	10 mV/V	4	■			
	<b>HP1101</b>	High Pressure Transmitter from 2,500 to 5,000 bar, DIN EN 175301-803-A	0-5 V	4	■			
	<b>HP1111</b>	High Pressure Transmitter from 2,500 to 5,000 bar, DIN EN 175301-803-A	0-5 V	3	■			
	<b>HP1102</b>	High Pressure Transmitter from 2,500 to 5,000 bar, DIN EN 175301-803-A	0-10 V	4	■			
	<b>HP1112</b>	High Pressure Transmitter from 2,500 to 5,000 bar, DIN EN 175301-803-A	0-10 V	3	■			
	<b>HP1103</b>	High Pressure Transmitter from 2,500 to 5,000 bar, DIN EN 175301-803-A	4-20 mA	2	■			
<b>Lopres</b> Low Pressure	<b>LP1000</b>	Low Pressure Transmitter for air and liquid, DIN EN 175301-803-A	10 mV/V	4			■	■
	<b>LP1001</b>	Low Pressure Transmitter for air and liquid, DIN EN 175301-803-A	0-5 V	4			■	■
	<b>LP1011</b>	Low Pressure Transmitter for air and liquid, DIN EN 175301-803-A	0-5 V	3			■	■
	<b>LP1002</b>	Low Pressure Transmitter for air and liquid, DIN EN 175301-803-A	0-10 V	4			■	■
	<b>LP1012</b>	Low Pressure Transmitter for air and liquid, DIN EN 175301-803-A	0-10 V	3			■	■
	<b>LP1003</b>	Low Pressure Transmitter for air and liquid, DIN EN 175301-803-A	4-20 mA	2			■	■



# SUCO Group

Worldwide at your side



**ARGENTINIA**

**Meditecna S.R.L.**  
 Phone: +54-11 4585 7005  
 Fax: +54-11 4585 7005  
 www.mediatecna.com.ar  
 meditecna@mediatecna.com.ar



**AUSTRALIA**

**ANZ Controls Pty. Ltd.**  
 Phone: +61-7-55358700  
 Fax: +61-7-55358744  
 www.anzcontrols.com.au  
 sales@anzcontrols.com.au



**AUSTRIA**

**BIBUS Austria GmbH**  
 Phone: +43-2242-33388  
 Fax: +43-2242-3338810  
 www.bibus.at  
 info@bibus.at



**BELARUS**



**ESTONIA**



**LATVIA**



**LITHUANIA**

**UAB Lintera**  
 Phone: +375-17-3870240  
 Fax: +375-17-3870250  
 www.lintera.info  
 minsk@lintera.info



**BELGIUM**



**LUXEMBOURG**

**Bintz Technics NV**  
 Phone: +32-2-7204916  
 Fax: +32-2-7203750  
 www.bintz.be  
 info@bintz.be



**BOSNIA AND  
 HERZEGOVINA**



**SERBIA**

**BIBUS doo**  
 Phone: +38-755-423-444  
 Fax: +38-755-423-444  
 www.bibus.ba  
 info@bibus.ba



**BRAZIL**

**Pressure Comercial Ltda.**  
 Phone: +55-11-46882113  
 Fax: +55-11-42084028  
 www.pws.com.br  
 pressure@pws.com.br



**BULGARIA**

**BIBUS Bulgaria OOD**  
 Phone: +359-2 971 98 08  
 Fax: +359-2 927 32 64  
 www.bibus.bg  
 info@bibus.bg



**CHILE**

**MX CHILE**  
 Phone: +56-995-460-974  
 Fax: +56-412-911-400  
 www.mxchile.com  
 contacto@mxchile.com



**CHINA**

**Mintai Hydraulics Shanghai**  
 Phone: +86-21-68393909  
 Fax: +86-21-68393955  
 www.mintaigroup.com  
 sales@mintaigroup.com



**COLOMBIA**

**Instrumatic S.A.S.**  
 Phone: +57-1616 4169  
 Fax: +57-1257 2005  
 www.instrumatic.com.co  
 ventas@instrumatic.com.co



**CROATIA**

**BIBUS Zagreb d.o.o.**  
 Phone: +385-1-3818004  
 Fax: +385-1-3818005  
 www.bibus.hr  
 bibus@bibus.hr



**CZECH REPUBLIC**

**BIBUS s.r.o.**  
 Phone: +420-547 125 300  
 Fax: +420-547 125 310  
 www.tlakovespinace.cz  
 bibus@bibus.cz



**DENMARK**

**OEM Automatic Klitsø A/S**  
 Phone: +45-70106400  
 Fax: +45-70106410  
 www.oemklitso.dk  
 info@oemklitso.dk



**EGYPT**



**JORDAN**



**LEBANON**



**SAUDI ARABIA**

**EHE EGYPTIAN HYDRAULIC  
 ENGINEERING**

Phone: +202-24501890  
 Fax: +202-24501892  
 www.ehehydraulic.com  
 s.zeyada@ehehydraulic.com



**FINLAND**

**OEM Finland Oy**  
 Phone: +358-207-499499  
 Fax: +358-207-499456  
 www.oem.fi info@oem.fi



**FRANCE**

**SUCO VSE France**  
 Phone: +33 2 43 14 14 21  
 Fax: +33 2 43 14 14 25  
 info@sucovse.fr  
 www.sucovse.fr



**GERMANY**

**Ifaug GmbH**  
 Phone: +49-2151-300478  
 www.ifaug.de  
 ifaug@web.de

**Kania & Edinger GmbH**  
 Phone: +49-5235-501580  
 www.kania-antriebstechnik.de  
 info@kania-antriebstechnik.de

**Helmut Rossmann GmbH**  
 Phone: +49-7161-30900  
 www.rossmann.de  
 info@rossmann.de

**SUKU Druck- und  
 Temperaturmesstechnik GmbH**  
 Phone: +49-37208-2717  
 www.suku.de  
 contact@suku.de



**GERMANY**

**SUCO Robert Scheuffele**  
 Phone: +49-7142-597-0  
 Fax: +49-7142-597-19  
 www.suco.de info@suco.de



**GREECE**

**NRG System**  
 Phone: +30-25310-83366  
 Fax: +30-25310-83367  
 www.nrgsystem.gr  
 info@nrgsystem.gr



**HUNGARY**

**Megawatt Villamosipari Kft**  
 Phone: +36-33-454000  
 Fax: +36-33-454494  
 www.megawatt.hu  
 megawatt@megawatt.hu



**INDIA**

**NORTH INDIA  
 (Maharashtra, Chhattisgarh,  
 Orissa)**

**BEDA Flow Systems Pvt. Ltd.**  
 Phone: +91-120-432 99 90  
 Fax: +91-120-4 08 00 22  
 www.bedaflow.com  
 info@bedaflow.com

**SOUTH INDIA**

**Adroit Technologies**  
 Phone: +91-9663395186  
 Fax: +91-1147619422  
 adroittechnology@gmail.com



**INDONESIA**

**PT Surya Sarana Dinamika**  
 Phone: +62-21-65835077 / 78  
 Fax: +62-21-65835079 / 80  
 www.suryasarana.com  
 sales@suryasarana.com



**ISRAEL**

**Ilan & Gavish  
 Automation Service Ltd.**  
 Phone: +972-3-9221824  
 Fax: +972-3-9240761  
 www.ilan-gavish.co.il  
 asaf@ilan-gavish.com



**ITALY**

**Ma.In.A. Srl**  
 Phone: +39-02-55300732 / 762  
 Fax: +39-02-55300762  
 www.mainasrl.it  
 mainami@iol.it



**JAPAN**

**Japan Flow Controls Co., Ltd.**  
 Phone: +81-3-5209 3393  
 Fax: +81-3-5256 8838  
 www.flow-jfc.com  
 yamanaka@flow-jfc.com



**KOREA**

**CONTINENTAL GLOBAL LTD.**  
 Phone: +82-2-4221615  
 Fax: +82-2-4146977  
 www.suco.co.kr  
 info@suco.co.kr



**MALAYSIA**

**Active Control Asiatech (M) Sdn Bhd**  
 Phone: +603-777 31 633  
 Fax: +603-777 31 669  
 www.activecontrol.com.my  
 gary.aca@gmail.com



**NETHERLANDS**

**Solar Nederland BV**  
 Phone: +31-88-7652700  
 Fax: +31-72-5192790  
 www.solarnederland.nl  
 industrie@solarnederland.nl



**NEW ZEALAND**

**ANZ Controls Pty. Ltd.**  
 Phone: +64-3-3435904  
 Fax: +64-3-3435906  
 www.anzcontrols.com.au  
 sales@anzcontrols.com.au



**NORWAY**

**OEM Automatic AS**  
 Phone: +47-32-210500  
 Fax: +47-32-210501  
 www.oem.no  
 post@oem.no



**PERU**

**EGLOMIN**  
 Phone: +51-1 2856248  
 www.eglomin.com  
 ventas@eglomin.com



**PHILIPPINES**

**ACTIVE CONTROL ENGINEERING AND SUPPLIES**  
 Phone: +632 871-0273  
 Fax: +632 781-3964  
 www.activecontrolengineering.com  
 sales@activecontrol.com.ph



**POLAND**

**BIBUS Menos Sp. z o.o**  
 Phone: +48-58-6609570  
 Fax: +48-58-6617132  
 www.bibusmenos.pl  
 info@bibusmenos.pl



**PORTUGAL**

**BIBUS Portugal, Lda**  
 Phone: +351-22-906-50-50  
 Fax: +351-22-906-50-53  
 www.bibus.pt  
 info@bibus.pt



**ROMANIA**

**BIBUS SES srl**  
 Phone: +40-356-446500  
 Fax: +40-356-446660  
 www.bibus.ro  
 office@bibus.ro



**RUSSIA**

**BIBUS o.o.o.**  
 Phone: +7-812-3094151  
 +7-499-7030442  
 Fax: +7-812-3094151  
 +7-499-7030442  
 www.bibus.ru  
 info@bibus.ru



**SINGAPORE**

**Elshin International Pte Ltd**  
 Phone: +65-6286 7707  
 Fax: +65-6747 2477  
 www.elshin.com  
 elshin@singnet.com.sg



**SLOVAKIA**

**BIBUS SK, s.r.o.**  
 Phone: +421-37-7777-957  
 Fax: +421-37-7777-969  
 www.bibus.sk  
 sale@bibus.sk



**SLOVENIA**

**INOTEH d.o.o.**  
 Phone: +386-2-6730134  
 Fax: +386-2-6652081  
 www.inoteh.si  
 info@inoteh.si



**SOUTH AFRICA**

**Remag (Pty) Ltd.**  
 Phone: +27-11-3155672  
 Fax: +27-11-3155570/1  
 www.remag.co.za  
 sales@remag.co.za



**SPAIN**

**BIBUS Spain, S.L.**  
 Phone: +34-986 24 72 86  
 Fax: +34-986 20 92 47  
 www.bibus.es  
 info@bibus.es



**SWEDEN**

**OEM Automatic AB**  
 Phone: +46-75-2424100  
 Fax: +46-75-2424210  
 www.oemautomatic.se  
 info@aut.oem.se



**SWITZERLAND**



**LIECHTENSTEIN**

**BIBUS AG**  
 Phone: +41-44 877 50 11  
 Fax: +41-44 877 58 51  
 www.bibus.ch  
 info@bibus.ch



**TAIWAN**

**Daybreak Int'l (Taiwan) Corp.**  
 Phone: +886-2-88661234  
 Fax: +886-2-88661239  
 www.daybreak.com.tw  
 day111@ms23.hinet.net



**THAILAND**

**CNS Engineering Service Co., Limited**  
 Phone: +662-157 2407-8  
 Fax: +662-583 5449  
 www.cns-universal.co.th  
 wichai@cns-universal.co.th



**TURKEY**

**Mert Teknik Fabrika Malzemeleri Tic. ve San. A.Ş.**  
 Phone: +90-216 526 43 40  
 Fax: +90-216 526 43 45  
 www.mert.com  
 info@mert.com



**UK**



**IRELAND**

**OEM Automatic Ltd**  
 Phone: +44-800-7313187  
 +44-116-2849900  
 Fax: +44-116-2841721  
 www.oem.co.uk  
 information@uk.oem.se



**UKRAINE**

**BIBUS Ukraine TOV**  
 Phone: +380-44-5454404  
 Fax: +380-44-5455483  
 www.bibus.ua  
 info@bibus.ua



**BAHRAIN**



**UNITED ARAB EMIRATES**



**KUWAIT**



**OMAN**



**QATAR**



**YEMEN**

**Synergies Tech**  
 Phone: +971-4-4275069  
 Fax: +971-4-4324256  
 www.synergies-group.com  
 info@synergies-group.com



**USA**



**CANADA**

**SUCO Technologies Inc.**  
 Phone: +1-561-989-8499  
 Fax: +1-561-989-8816  
 www.suco-tech.com  
 info@suco-tech.com



**VIETNAM**

**BIBUS VIETNAM E&C Co. Ltd.**  
 Tel: +84 (0) 8 378 534 31  
 Fax: +84 (0) 4 356 834 29  
 www.bibus.vn  
 info@bibus.vn

**QUYNH ENGINEERING CORP.**  
 Phone: +84-8-3771 5330  
 Fax: +84-8-3771 5320  
 www.quynh.vn  
 info@quynh.vn

# Order correctly - it's quite simple

## Explanation of SUCO article numbers

$p_{max}$ in bar	Adjustment range in bar	Tolerance at room temperature in bar	Male thread	Article number
---------------------	----------------------------	---	-------------	----------------

### 0170 Diaphragm pressure switches with spade terminals

$p_{max}$ in bar	Adjustment range in bar	Tolerance at room temperature in bar	Male thread	Article number
100 <sup>1)</sup>	0.3 – 1.5	± 0.2	G 1/4	0170 – 457 03 – X – 003 – YZ
			M 10x1 con.	0170 – 457 01 – X – 001 – YZ
			M 12x1.5 cyl.	0170 – 457 02 – X – 002 – YZ
			NPT 1/8	0170 – 457 04 – X – 318 – YZ
			NPT 1/4	0170 – 457 09 – X – 314 – YZ
			7/16-20 UNF	0170 – 457 20 – X – 301 – YZ
			9/16-18 UNF	0170 – 457 21 – X – 302 – YZ

**Article number:** 0170 – 457 04 – X – 318 – YZ

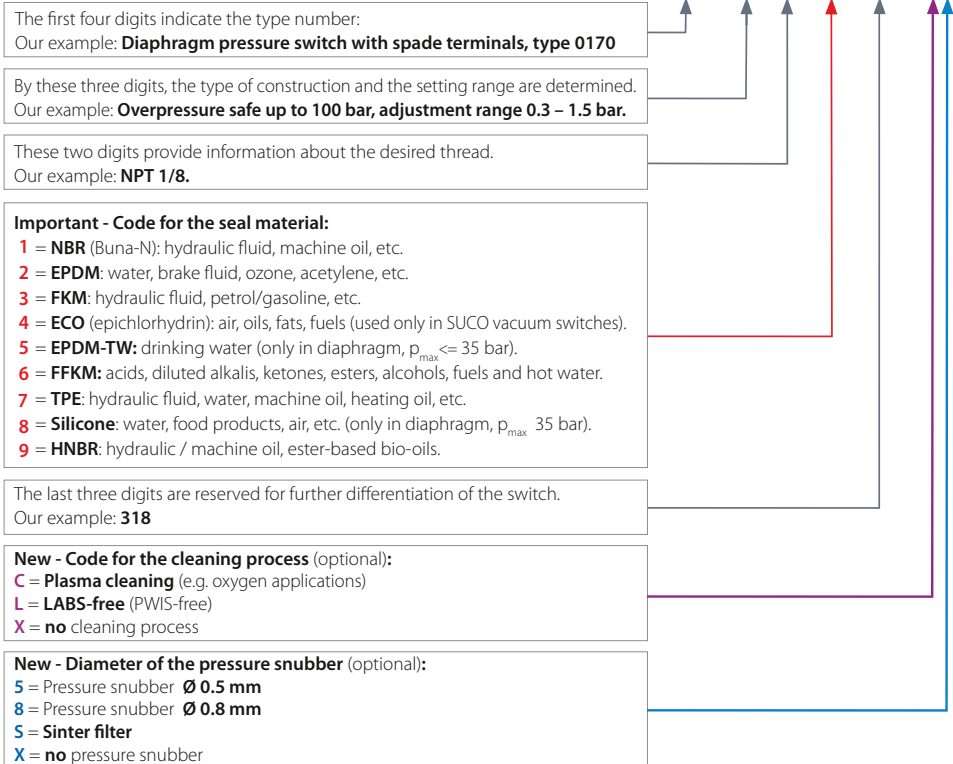

### Abbreviated coding explanation is embossed on the hex surface areas of the pressure switches.

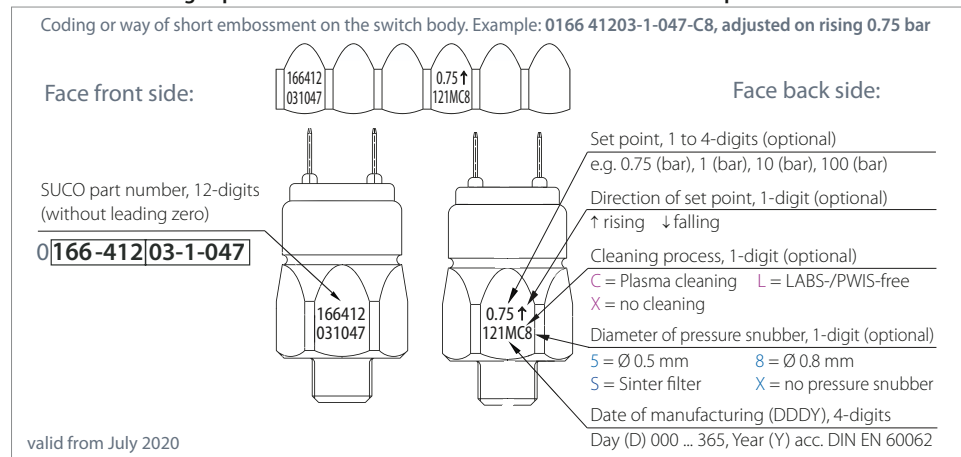

# Questionnaire for Mechanical Pressure Switches

This questionnaire should be helpful to show, which information are important to give you a fast and detailed answer to your inquiry. Please fulfil as much points as you can; not all variations are implementable!

## Contact data

Company / customer:					
Address:				ZIP Code / City:	
Contact person:				Division:	
Email:			Telephone:		
Business field:	<input type="checkbox"/> manufacture of components	<input type="checkbox"/> service	<input type="checkbox"/> OEM	<input type="checkbox"/> dealer	<input type="checkbox"/> customer:
Project:			<input type="checkbox"/> new	<input type="checkbox"/> redesign	<input type="checkbox"/> replaces competitor:
Quantity:			<input type="checkbox"/> annual	<input type="checkbox"/> one-time	<input type="checkbox"/> sample till:
Target price:					

## Operating conditions

Function / application:					
Media:					
Media temperature:				Environment temp.:	
Set point:		<input type="checkbox"/> mbar	<input type="checkbox"/> bar	<input type="checkbox"/> PSI	<input type="checkbox"/> rising <input type="checkbox"/> falling
Reset point:		<input type="checkbox"/> mbar	<input type="checkbox"/> bar	<input type="checkbox"/> PSI	<input type="checkbox"/> rising <input type="checkbox"/> falling
Set points:	<input type="checkbox"/> adjusted at works	<input type="checkbox"/> adjustable from		to:	
Pressure range		<input type="checkbox"/> mbar	<input type="checkbox"/> bar	<input type="checkbox"/> PSI	
Pressure frequency:		Hz	Life time:		
Switching frequency:	<input type="checkbox"/> continuous	<input type="checkbox"/> irregularly	<input type="checkbox"/>	cycles per day	<input type="checkbox"/> one-time
Max. working pressure:				Min. working pressure:	
Profile of pressure:	<input type="checkbox"/> static	<input type="checkbox"/> dynamic	Pressure ramp rate:		bar/ms
Shock load:		g	Vibrations:		m/s <sup>2</sup>

## Electrical data

Working voltage $U_b$ :				Working current $I_b$ :	
Load:		<input type="checkbox"/> resistive	<input type="checkbox"/> inductive	<input type="checkbox"/> capacitive	<input type="checkbox"/> inrush
Utilization category:	<input type="checkbox"/> AC12	<input type="checkbox"/> AC14	<input type="checkbox"/> DC12	<input type="checkbox"/> DC13	
Switching function:	<input type="checkbox"/> SPDT (NO)	<input type="checkbox"/> SPDT (NC)	<input type="checkbox"/> SPDT (changeover)		
Output signal:	<input type="checkbox"/> 0-10 V	<input type="checkbox"/> 4-20 mA	<input type="checkbox"/> 0.5 - 4.5 V ratiometric	<input type="checkbox"/> other: <input type="text"/>	

## General data

Media connection				IP protection class:	
Electrical connection:	<input type="checkbox"/> screw terminal	<input type="checkbox"/> spade terminal	<input type="checkbox"/> integrated plug	<input type="checkbox"/> other: <input type="text"/>	
	<input type="checkbox"/> cable + lenght	<input type="text"/>	mm	<input type="checkbox"/> incl. socket device (EN 175301-803-A)	
Connector- / cable:				Housing:	<input type="checkbox"/> steel <input type="checkbox"/> stainless steel <input type="checkbox"/> brass
Remarks:					

# Questionnaire for Electronic Pressure Switches

This questionnaire should be helpful to show, which information are important to give you a fast and detailed answer to your inquiry. Please fulfil as much points as you can; not all variations are implementable!

## Contact data

Company / customer:			
Address:		ZIP Code / City:	
Contact person:	Division:		
Email:	Telephone:	Telefax:	
Business field:	<input type="checkbox"/> manufacture of components	<input type="checkbox"/> service	<input type="checkbox"/> OEM <input type="checkbox"/> dealer <input type="checkbox"/> customer:
Project:		<input type="checkbox"/> new <input type="checkbox"/> redesign	<input type="checkbox"/> replaces competitor:
Quantity:		<input type="checkbox"/> annual <input type="checkbox"/> one-time	<input type="checkbox"/> sample till:
Target price:			

## Operating conditions

Function / application:			
Media:			
Media temperature:		Environment temp.:	
Pressure range:	<input type="checkbox"/> mbar <input type="checkbox"/> bar <input type="checkbox"/> PSI		
Pressure frequency:	Hz	Life time:	cycles
Switching frequency:	<input type="checkbox"/> continuous <input type="checkbox"/> irregularly	<input type="checkbox"/>	cycles per day <input type="checkbox"/> one-time
Max. working pressure:		Min. working pressure:	
Profile of pressure:	<input type="checkbox"/> static <input type="checkbox"/> dynamic	Pressure ramp rate:.	bar/ms
Shock load:	g	Vibrations:	m/s <sup>2</sup>
Hysteresis	bar / % FS	Switching Function:	<input type="checkbox"/> NO <input type="checkbox"/> NC

## Electrical data

Working voltage $U_b$ :		Working current $I_b$ :	
Output(s):	<input type="checkbox"/> 4-20 mA <input type="checkbox"/> 1 switching output	<input type="checkbox"/> 2 switching outputs	<input type="checkbox"/> other: <input type="text"/>
Switch. output current:	A	Output Function:	<input type="checkbox"/> PNP <input type="checkbox"/> NPN

## General data

IP protection class:	<input type="checkbox"/> IP65	<input type="checkbox"/> IP67	<input type="checkbox"/> IP6K9K	<input type="checkbox"/> other: <input type="text"/>
Media connection (thread):	<input type="checkbox"/> G 1/4 -E male	<input type="checkbox"/> NPT 1/4	<input type="checkbox"/> M 10x1 cyl.	<input type="checkbox"/> 7/16-20 UNF <input type="checkbox"/> other: <input type="text"/>
	<input type="checkbox"/> G 1/4 -E female	<input type="checkbox"/> NPT 1/8	<input type="checkbox"/> M 14x1.5 -E	<input type="checkbox"/> 9/16-18 UNF
	<input type="checkbox"/> G 1/4 -A			
Electrical connection:	<input type="checkbox"/> M 12x1 EN 61076-2-101-A	<input type="checkbox"/> DEUTSCH DT04-3P	<input type="checkbox"/> AMP Superseal 1.5	
	<input type="checkbox"/> EN 175301-803-A socket device	<input type="checkbox"/> DEUTSCH DT04-4P	<input type="checkbox"/> DIN 72585 (Bayonet)	
	<input type="checkbox"/> Cable socket with PG 7 cable gland	<input type="checkbox"/> Electronic display	<input type="checkbox"/> other: <input type="text"/>	
	<input type="checkbox"/> Cable connection 2 m			
Seal material:	<input type="checkbox"/> NBR	<input type="checkbox"/> EPDM	<input type="checkbox"/> FKM	<input type="checkbox"/> TPE
Remarks:				

# Questionnaire for Pressure Transmitters

This questionnaire should be helpful to show, which information are important to give you a fast and detailed answer to your inquiry. Please fulfil as much points as you can; not all variations are implementable!

## Contact data

Company / customer:					
Address:				ZIP Code / City:	
Contact person:				Division:	
Email:			Telephone:		Telefax:
Business field:	<input type="checkbox"/> manufacture of components	<input type="checkbox"/> service	<input type="checkbox"/> OEM	<input type="checkbox"/> dealer	<input type="checkbox"/> customer:
Project:			<input type="checkbox"/> new	<input type="checkbox"/> redesign	<input type="checkbox"/> replaces competitor:
Quantity:			<input type="checkbox"/> annual	<input type="checkbox"/> one-time	<input type="checkbox"/> sample till:
Target price:					

## Operating conditions

Function / application:					
Media:					
Media temperature:				Environment temp.:	
Set point:	<input type="checkbox"/> mbar	<input type="checkbox"/> bar	<input type="checkbox"/> PSI	<input type="checkbox"/> rising	<input type="checkbox"/> falling
Reset point:	<input type="checkbox"/> mbar	<input type="checkbox"/> bar	<input type="checkbox"/> PSI	<input type="checkbox"/> rising	<input type="checkbox"/> falling
Set points:	<input type="checkbox"/> adjusted at works	<input type="checkbox"/> adjustable from		to:	
Pressure range	<input type="checkbox"/> mbar	<input type="checkbox"/> bar	<input type="checkbox"/> PSI		
Pressure frequency:			Hz	Life time:	
Switching frequency:	<input type="checkbox"/> continuous	<input type="checkbox"/> irregularly	<input type="checkbox"/>	cycles per day	<input type="checkbox"/> one-time
Max. working pressure:				Min. working pressure:	
Profile of pressure:	<input type="checkbox"/> static	<input type="checkbox"/> dynamic	Pressure ramp rate::		bar/ms
Shock load:				Vibrations:	m/s <sup>2</sup>

## Electrical data

Working voltage $U_s$ :				Working current $I_s$ :	
Output signal:	<input type="checkbox"/> 4 - 20 mA ( $U_s$ 10-32 VDC)	<input type="checkbox"/> 0 - 10 V ( $U_s$ 12-32 VDC)	<input type="checkbox"/> 0.5 - 4.5 V ratiometric ( $U_s$ 5VDC +/- 10%, max. 6.5 V)	<input type="checkbox"/> other:	

## General data

IP protection class:	<input type="checkbox"/> IP65	<input type="checkbox"/> IP67	<input type="checkbox"/> IP6K9K	<input type="checkbox"/> other:	
Media connection (thread):	<input type="checkbox"/> G 1/4 -E	<input type="checkbox"/> G 1/4 -A	<input type="checkbox"/> NPT 1/8	<input type="checkbox"/> NPT 1/4	
	<input type="checkbox"/> M 10x1 cyl.	<input type="checkbox"/> 7/16-20 UNF	<input type="checkbox"/> 9/16-18 UNF	<input type="checkbox"/> M 14x1.5 - E	
	<input type="checkbox"/> other: <input type="text"/>				
Electrical connection:	<input type="checkbox"/> M12x1	<input type="checkbox"/> DIN 175301-803 -A	<input type="checkbox"/> DIN 72585 (Bayonet)	<input type="checkbox"/> AMP Superseal 1.5	
	<input type="checkbox"/> DEUTSCH DT0-4P	<input type="checkbox"/> DEUTSCH DT04-3P	<input type="checkbox"/> Cable Connection 2m	<input type="checkbox"/> other:	
Accessories:	<input type="checkbox"/> Display STD, model	<input type="checkbox"/>	<input type="checkbox"/> M12x1 connector / cable, model:	<input type="checkbox"/>	
Remarks:					

# Pressure Monitoring Systems and Transmission Technology

Our complete product range and sales network can be found online or in our catalogs.

Contact us or go online now.



**Office Location:** 863 Bowsprit Road, Chula Vista, CA 91914  
**Warehouse Location:** 8268 Clairemont Mesa Blvd, Ste 302, San Diego, CA 92111

**Line 1:** +1 (619)-616-7350  
**Mobile:** +1 (619)-600-1015

info@logicbus.com  
sales@logicbus.com  
support@logicbus.com  
orders@logicbus.com



**Sucursal:** Av. Miguel Hidalgo y Costilla #1443 Piso 6 Col. Americana (Torre Iclar) C.P. 44160, Guadalajara, Jalisco

**Tel:** +52 (33)-3854-5975

**WhatsApp:** +52 (55)-5431-6718  
**WhatsApp:** +52 (33)-3443-8556

ventas@logicbus.com  
soporte@logicbus.com  
finanzas@logicbus.com

Contact Us